



# UL 987

## STANDARD FOR SAFETY

### Stationary and Fixed Electric Tools

[ULNORM.COM](https://www.ulnorm.com) : Click to view the full PDF of UL 987 2020

[ULNORM.COM](https://ULNORM.COM) : Click to view the full PDF of UL 987 2020

UL Standard for Safety for Stationary and Fixed Electric Tools, UL 987

Eighth Edition, Dated October 19, 2011

### **Summary of Topics**

***The revisions of ANSI/UL 987 dated May 12, 2020 add references to UL 61800-5-1, Standard For Adjustable Speed Electric Power Drive Systems to replace all references to UL 508C, Standard For Power Conversion Equipment; [6.6.4.1](#) and [6.14.4.4](#).***

Text that has been changed in any manner or impacted by UL's electronic publishing system is marked with a vertical line in the margin.

The revised requirements are substantially in accordance with Proposal(s) on this subject dated February 14, 2020.

All rights reserved. No part of this publication may be reproduced, stored in a retrieval system, or transmitted in any form by any means, electronic, mechanical photocopying, recording, or otherwise without prior permission of UL.

UL provides this Standard "as is" without warranty of any kind, either expressed or implied, including but not limited to, the implied warranties of merchantability or fitness for any purpose.

In no event will UL be liable for any special, incidental, consequential, indirect or similar damages, including loss of profits, lost savings, loss of data, or any other damages arising out of the use of or the inability to use this Standard, even if UL or an authorized UL representative has been advised of the possibility of such damage. In no event shall UL's liability for any damage ever exceed the price paid for this Standard, regardless of the form of the claim.

Users of the electronic versions of UL's Standards for Safety agree to defend, indemnify, and hold UL harmless from and against any loss, expense, liability, damage, claim, or judgment (including reasonable attorney's fees) resulting from any error or deviation introduced while purchaser is storing an electronic Standard on the purchaser's computer system.

No Text on This Page

[ULNORM.COM](http://ULNORM.COM) : Click to view the full PDF of UL 987 2020

**OCTOBER 19, 2011**  
(Title Page Reprinted: May 12, 2020)



**ANSI/UL 987-2020**

1

## **UL 987**

### **Standard for Stationary and Fixed Electric Tools**

First Edition – January, 1971  
Second Edition – August, 1972  
Third Edition – August, 1978  
Fourth Edition – June, 1983  
Fifth Edition – November, 1991  
Sixth Edition – August, 1994  
Seventh Edition – November, 2007

#### **Eighth Edition**

**October 19, 2011**

This ANSI/UL Standard for Safety consists of the Eighth Edition including revisions through May 12, 2020.

The most recent designation of ANSI/UL 987 as an American National Standard (ANSI) occurred on May 1, 2020. ANSI approval for a standard does not include the Cover Page, Transmittal Pages, and Title Page.

The Department of Defense (DoD) has adopted UL 987 on May 20, 1976. The publication of revised pages or a new edition of this Standard will not invalidate the DoD adoption.

Comments or proposals for revisions on any part of the Standard may be submitted to UL at any time. Proposals should be submitted via a Proposal Request in UL's On-Line Collaborative Standards Development System (CSDS) at <https://csds.ul.com>.

UL's Standards for Safety are copyrighted by UL. Neither a printed nor electronic copy of a Standard should be altered in any way. All of UL's Standards and all copyrights, ownerships, and rights regarding those Standards shall remain the sole and exclusive property of UL.

**COPYRIGHT © 2020 UNDERWRITERS LABORATORIES INC.**

No Text on This Page

[ULNORM.COM](http://ULNORM.COM) : Click to view the full PDF of UL 987 2020

## CONTENTS

### INTRODUCTION

1	Scope .....	9
2	Units of Measurement .....	9
3	Undated References .....	10
4	Glossary.....	10

### CONSTRUCTION

5	General.....	11
6	Components.....	11
	6.1 General.....	11
	6.2 Attachment plugs, receptacles, connectors, and terminals .....	13
	6.3 Batteries .....	14
	6.4 Boxes and raceways .....	14
	6.5 Capacitors and filters .....	14
	6.6 Controls .....	14
	6.7 Cords, cables, and internal wiring.....	16
	6.8 Cord reels .....	17
	6.9 Film-coated wire (magnet wire) .....	17
	6.10 Ground-fault, arc-fault, and leakage current detectors/interrupters .....	17
	6.11 Insulation systems.....	18
	6.12 Light sources and associated components.....	18
	6.13 Marking and labeling systems .....	18
	6.14 Motors and motor overload protection.....	19
	6.15 Overcurrent protection.....	21
	6.16 Polymeric materials and enclosures .....	21
	6.17 Power supplies .....	22
	6.18 Printed wiring boards.....	22
	6.19 Semiconductors and small electrical and electronic components .....	22
	6.20 Supplemental insulation, insulating bushings, and assembly aids .....	23
	6.21 Switches .....	23
	6.22 Transformers .....	24
7	Frame and Enclosure .....	24
	7.1 General.....	24
	7.2 Enclosures of metallic materials .....	24
	7.3 Enclosures of polymeric materials .....	25
8	Accessibility of Live Parts .....	26
9	Exclusion of Foreign Matter .....	28
10	Mechanical Assembly.....	29
11	Protection Against Corrosion.....	29
12	Power Supply Connections– Permanently Connected Tools .....	30
	12.1 General.....	30
	12.2 Wiring compartments .....	30
	12.3 Wiring terminals and leads.....	30
	12.4 Grounded power-supply conductor.....	31
	12.5 Equipment-grounding conductor .....	31
13	Power Supply Connections – Cord-Connected Tools .....	32
	13.1 Cords and plugs.....	32
	13.2 Strain relief.....	34
14	Live Parts .....	35
15	Internal Wiring .....	35
16	Interconnecting Cords .....	37

17	Insulating Material .....	38
18	Motors .....	38
19	Switches and Controls .....	38
20	Lampholders .....	39
21	Overcurrent-Protective Devices .....	39
22	Capacitors .....	39
23	Spacings .....	40
24	Grounding .....	42
25	Lasers .....	44

## PROTECTION AGAINST INJURY TO PERSONS

### ALL TOOLS

26	General .....	44
27	Attachments and Accessories .....	45
28	Temperatures .....	45
29	Rotating Members .....	45
30	Enclosures and Guards .....	46
31	Stability .....	48
32	Mechanical Assembly .....	49
33	Switches and Controls .....	49
34	Controls – End Product Test Parameters .....	50
	34.1 General .....	50
	34.2 Auxiliary controls .....	50
	34.3 Operating Controls (regulating controls) .....	50
	34.4 Protective controls (limiting controls) .....	52
	34.5 Controls using a temperature sensing device .....	53
35	Tables .....	54
36	Miter Grooves .....	54

### SPECIFIC TOOLS

37	Drill Presses .....	54
38	Bench and Pedestal Type Grinders .....	55
39	Jointers .....	62
40	Band Saws .....	64
41	Radial-Arm Saws .....	64
42	Scroll Saws and Jigsaws .....	66
43	Table Saws .....	67
	43.1 Glossary .....	67
	43.2 General .....	67
	43.3 Table saw blade guard .....	68
	43.4 Riving knife .....	68
	43.5 Extended riving knife (fixed or adjustable) .....	69
	43.6 Antikickback device(s) .....	69
	43.7 Rip fence for table saws .....	70
	43.8 Table saw insert .....	70
	43.9 Table saw arbor .....	70
	43.10 Additional table saw requirements .....	70
44	Sanding Machines .....	71
45	Shapers .....	71
46	Lathes .....	72
47	Miter Saws .....	73
48	Abrasive Cutoff Machines .....	75

49	Table Tile Saws .....	76
50	Panel Saws .....	76

## PERFORMANCE

51	General .....	82
52	Leakage Current Test .....	83
53	Starting Current Test .....	86
54	Current Input Test.....	86
55	Temperature Test .....	88
	55.1 General .....	88
	55.2 Temperature measurements .....	90
	55.3 Operation for temperature test .....	90
56	Dielectric Voltage Withstand Test.....	91
57	Leakage Current Test Following Humidity Conditioning .....	92
58	Impact test.....	92
59	Strain Relief Test.....	93
60	Push Back Relief Test.....	93
61	Sharp Edges Test.....	93
62	Switches and Controls Test.....	94
	62.1 General .....	94
	62.2 Reversing controls .....	94
	62.3 Speed change controls .....	95
63	Capacitor Test.....	95
64	Abnormal Operation Test .....	95
65	Bonding Overload Test .....	96
66	Resistance of Grounding Path Test.....	96
67	Conditioning of Polymeric Materials.....	96
68	Tests of Polymeric Enclosures Following Oven Conditioning.....	97
69	Polymeric Material as Described in <a href="#">69.2</a> .....	97
	69.1 General .....	97
	69.2 Flame resistance test .....	97
	69.3 Thermal stability test .....	97
	69.4 Strain relief test.....	98
	69.5 Impact test.....	98
	69.6 Abnormal operation test.....	98
70	Polymeric Material as Described in <a href="#">70.2</a> .....	99
	70.1 General .....	99
	70.2 Burning rate.....	99
	70.3 Hot-wire ignition test.....	100
	70.4 Hot-wire ignition (HWI) – abnormal overload test .....	100
	70.5 Spacings to enclosure .....	103
	70.6 Arc resistance test.....	103
	70.7 Arc-ignition test.....	103
	70.8 Abnormal operation test.....	104
	70.9 Impact test.....	104
	70.10 Thermal stability.....	104
71	Drip Test.....	104
72	Flooding Test .....	105
73	Overflow Test.....	105
74	Test For Deterioration Of Parts .....	105
75	Test For Reliability Of Parts.....	106

## MANUFACTURING AND PRODUCTION TESTS

76	Dielectric Voltage Withstand Test.....	107
77	Grounding Continuity Test.....	109

## RATING

78	Electrical Rating.....	109
----	------------------------	-----

## MARKING

79	General.....	109
80	Details.....	110
81	Cautionary.....	112
81.1	All tools.....	112
81.2	Combination tools.....	113
81.3	Grinders.....	113
81.4	Drill presses.....	113
81.5	Jointers.....	114
81.6	Radial-arm saws.....	114
81.7	Table saws.....	115
81.8	Band saws.....	115
81.9	Lathes.....	115
81.10	Shapers.....	116
81.11	Sanders.....	116
81.12	Miter saws.....	117
81.13	Other tools.....	117
81.14	Garage (Automotive) Tools.....	117
81.15	Tile saws.....	117
81.16	Vertical panel saws.....	118

## INSTRUCTIONS

82	Instruction Manual.....	118
83	Instructions Pertaining to a Risk of Injury.....	119
83.1	General.....	119
83.2	Grinders.....	124
83.3	Drill Presses.....	124
83.4	Jointers.....	124
83.5	All saws.....	125
83.6	Radial arm saws.....	125
83.7	Band saws.....	126
83.8	Tile saws.....	126
83.9	Miter saws.....	127
83.10	Panel saws.....	127
83.11	Lathes.....	128
83.12	Shapers.....	128
83.13	Sanders – belt, disc, and belt-and-disc.....	128
83.14	Other Tools.....	128

## ACCESSORIES AND ATTACHMENTS

84	Scope.....	129
85	Construction.....	129
85.1	General.....	129

85.2	Materials .....	130
86	Performance .....	130
86.1	Impact testing – general .....	130
86.2	Sharp edges and projections.....	131
86.3	Rotating members test .....	131
86.4	Stability test.....	131
87	Marking .....	132
88	Instructions .....	134
88.1	General .....	134
88.2	All accessories and attachments .....	134
88.3	Specific accessories.....	134

## DOUBLE-INSULATED TOOLS

89	Scope .....	135
90	Construction .....	135
90.1	Glossary.....	135
90.2	General .....	137
90.3	Accessibility of live parts .....	138
90.4	Flexible Cord .....	139
90.5	Attachment plug.....	140
90.6	Internal wiring .....	140
90.7	Capacitors .....	141
90.8	Brush caps .....	141
90.9	Commutators and armature end turns.....	142
90.10	Switches.....	142
90.11	Brush holders.....	143
90.12	Spacings .....	144
91	Performance.....	144
91.1	Dielectric voltage withstand test .....	144
91.2	Leakage current test.....	144
91.3	Insulation resistance test .....	146
91.4	Resistance to impact test.....	146
91.5	Overload test .....	147
91.6	Armature investigation test .....	152
91.7	Leakage current following humidity test.....	155
92	Tests by the Manufacturer.....	155
93	Markings .....	156

## SUPPLEMENT SA – BATTERY-POWERED STATIONARY AND FIXED ELECTRIC TOOLS AND BATTERY PACKS

SA1	Scope .....	159
SA4	Glossary .....	159
SA5	Construction.....	159
SA7	Frame and Enclosure.....	160
SA8	Accessibility of Live Parts .....	160
SA9	Exclusion of Foreign Matter .....	160
SA11	Protection Against Corrosion .....	160
SA12	Power Supply Connections – Permanently Connected Tools.....	161
SA13	Power Supply Connections – Cord Connected Tools .....	161
SA14	Live Parts.....	161
SA15	Internal Wiring .....	161
SA16	Interconnecting Cords.....	162
SA17	Insulating Material .....	162
SA18	Motors .....	162

SA19	Switches and Controls .....	162
SA20	Lampholders .....	163
SA21	Overcurrent Protective Devices .....	163
SA22	Capacitors .....	163
SA23	Spacings .....	163
SA24	Grounding .....	164
SA28	Temperatures .....	164
SA47	Miter Saws .....	165
SA51	Performance – General .....	165
SA52	Leakage Current Test .....	165
SA53	Starting Current Test .....	165
SA54	Current Input Test .....	165
SA55	Temperature Test .....	165
SA56	Dielectric Voltage Withstand Test .....	165
SA57	Leakage Current Test Following Humidity Conditioning .....	165
SA58	Impact Test .....	166
SA59	Strain Relief Test .....	167
SA60	Push Back Relief Test .....	167
SA62	Switches and Controls Test .....	167
SA63	Capacitor Test .....	168
SA64	Abnormal Operation Test .....	168
SA65	Bonding Overload Test .....	168
SA66	Resistance of Grounding Path Test .....	168
SA67	Conditioning of Polymeric Materials .....	169
SA68	Tests of Polymeric Enclosure Following Oven Conditioning .....	170
SA69	Polymeric Material as Described in <a href="#">69.2</a> .....	170
SA70	Polymeric Material as Described in <a href="#">70.2</a> .....	170
SA71	Drip Test .....	170
SA72	Flooding Test .....	170
SA73	Overflow Test .....	170
SA74	Test for Deterioration of Parts .....	170
SA75	Test for Reliability of Parts .....	170
SA76	Dielectric Voltage Withstand Test .....	170
SA77	Grounding Continuity Test .....	170
SA78	Electrical Rating .....	171
SA79	General – Marking .....	171
SA80	Details .....	171
SA81	Cautionary .....	171
SA83	Instructions Pertaining to a Risk of Injury .....	172
SA89	Double Insulated Tools – Scope .....	172
SA90	Construction .....	172
SA91	Performance .....	172
SA92	Tests by the Manufacture .....	173
SA93	Markings .....	173

## INTRODUCTION

### 1 Scope

1.1 These requirements cover cord-connected or permanently-connected stationary and light industrial electric tools for use in accordance with the National Electrical Code, ANSI/NFPA 70 and provided with a means for:

- a) Grounding the tool on a branch circuit rated not more than 600 V and employing no universal motor rated more than 250 V; or
- b) Providing double insulation for a tool on a branch circuit involving a potential of not more than 150 V to ground.

1.2 These requirements also cover accessories and attachments for use with tools included in [1.1](#) if the accessories or attachments are:

- a) Identified by catalog number or equivalent product designation in the instruction manual for the tool; or
- b) Packed with the tool.

Specific requirements are outlined in Sections [85](#) – [88](#).

1.3 These requirements do not cover any of the following:

- a) Portable tools;
- b) Automated machine tools intended for production line use;
- c) Garage equipment with the exception of bench type brake lathes;
- d) Painting equipment; or
- e) Other equipment covered by individual requirements.

1.4 A stationary or fixed electric tool intended to be remotely or automatically controlled, or a permanently connected tool intended for continuous duty are judged on the basis of compliance with the requirements in this standard, insofar as they are applicable, and further examination and test to determine whether the tool is acceptable for the purpose.

1.5 These requirements do not cover accessories or attachments that:

- a) Are not packed with the tool; or
- b) Are not identified by catalog number or equivalent product designation in the instruction manual provided with the tool.

Accessories or attachments mentioned in mini-catalogs or flyers may or may not be provided with the tool.

### 2 Units of Measurement

2.1 Values stated without parentheses are the requirement. Values in parentheses are explanatory or approximate information.

### 3 Undated References

3.1 Any undated reference to a code or standard appearing in the requirements of this standard shall be interpreted as referring to the latest edition of that code or standard.

### 4 Glossary

4.1 In the following text, a requirement that applies only to a specific class or classes of stationary, fixed, and light industrial electric tools is so identified by a specific reference in the requirement to the class or classes of equipment involved. Absence of such specific reference or use of the term tool indicates that the requirement applies to all of the classes of equipment covered by this standard unless the context indicates otherwise.

4.2 For the purpose of this standard, the following definitions apply.

4.3 ACCESSORY – A device that is attached only to the spindle of the tool. Accessories include carbide tipped saw blades, wire brushes, and shaper cutters.

4.4 APPLIANCE COUPLER – A single-outlet, female contact device for attachment to a flexible cord as part of a detachable power-supply cord to be connected to an appliance inlet (motor attachment plug).

4.5 APPLIANCE INLET (Motor Attachment Plug) – A male contact device mounted on an end product appliance to provide an integral blade configuration for the connection of an appliance coupler or cord connector.

4.6 APPLIANCE (FLATIRON) PLUG – An appliance coupler type of device having a cord guard and a slot configuration specified for use with heating or cooking appliances.

4.7 ATTACHMENT – A device attached to the housing or other component of the tool that may or may not attach to the spindle. Attachments include tables to convert bench mounted tools to floor mounted tools, and devices that facilitate the use of tools such as a saw dust collection device.

4.8 COMPONENT – A device or fabricated part of the appliance covered by the scope of a safety standard dedicated to the purpose. When incorporated in an appliance, equipment otherwise typically field installed (e. g. luminaire) is considered to be a component. Unless otherwise specified, materials that compose a device or fabricated part, such as thermoplastic or copper, are not considered components.

4.9 CORD CONNECTOR – A female contact device wired on flexible cord for use as an extension from an outlet to make a detachable electrical connection to an attachment plug or, as an appliance coupler, to an equipment inlet.

4.10 CONTROL, AUTOMATIC ACTION – A control in which at least one aspect is non-manual.

4.11 CONTROL, AUXILIARY – A device or assembly of devices that provides a functional utility, is not relied upon as an operational or protective control, and therefore is not relied upon for safety. For example, an efficiency control not relied upon to reduce the risk of fire, electric shock, or injury to persons during normal or abnormal operation of the end product is considered an auxiliary control.

4.12 CONTROL, MANUAL – A device that requires direct human interaction to activate or rest the control.

4.13 CONTROL, OPERATING – A device or assembly of devices, the operation of which starts or regulates the end product during normal operation. For example, a thermostat, the failure of which a

thermal cutout/limiter or another layer of protection would reduce the risk of fire, electric shock, or injury to persons, is considered an operating control. Operating controls are also referred to as "regulating controls".

4.14 CONTROL, PROTECTIVE – A device or assembly of devices, the operation of which is intended to reduce the risk of fire, electric shock, or injury to persons during normal and reasonably anticipated abnormal operation of the appliance whereby during the evaluation of the protective control/circuit, the protective functions are verified under normal and single-fault conditions of the control. For example, a thermal cutout/limiter, or any other control/circuit relied upon for normal and abnormal conditions, is considered a protective control. Protective controls are also referred to as "limiting controls" and "safety controls".

4.15 CONTROL, TYPE 1 ACTION – The actuation of an automatic control for which the manufacturing deviation and the drift (tolerance before and after certain conditions) of its operating value, operating time, or operating sequence has not been declared and tested under this standard.

4.16 CONTROL, TYPE 2 ACTION – The actuation of an automatic control for which the manufacturing deviation and the drift (tolerance before and after certain conditions) of its operating value, operating time, or operating sequence have been declared and tested under this standard.

4.17 STATIONARY TOOL – Electric motor-operated or magnetically-driven machine so designed that the motor and the machine form an assembly which does not require support by hand and the material on which the machine performs the work is brought to the machine.

4.18 TOOL – A stationary or light industrial tool as specified in [1.1](#).

4.19 TRANSPORTABLE TOOL – A stationary tool that is cord connected and is easily transported to the work site by one person, simple devices to facilitate transportation may be incorporated, e.g. handles, wheels and the like.

## CONSTRUCTION

### 5 General

5.1 A tool shall employ materials throughout that are acceptable for the use, and shall be made and finished with the degree of uniformity and grade of workmanship practicable in a well-equipped factory.

5.2 A motor for a tool provided with a means for grounding may be shipped detached from the tool if both the motor and the tool comply with the applicable requirements in [8.5](#), [10.5](#), [10.6](#), [13.1.10](#), [15.18](#), [15.19](#), [16.1](#) – [16.4](#), [79.6](#), [80.9](#), [80.10](#), [83.1.4](#), and [83.1.5](#).

5.3 The motor of a double insulated tool shall be shipped attached to the tool.

### 6 Components

#### 6.1 General

6.1.1 A component of a product covered by this standard shall:

- a) Comply with the requirements for that component as indicated in [6.2](#) – [6.22](#);
- b) Be used in accordance with its rating(s) established for the intended conditions of use;
- c) Be used within its established use limitations or conditions of acceptability;

- d) Additionally comply with the applicable requirements in this end product standard; and
- e) Not contain mercury.

*Exception No. 1: A component of a product covered by this standard is not required to comply with a specific component requirement that:*

- a) Involves a feature or characteristic not required in the application of the component in the product;*
- b) Is superseded by a requirement in this standard; or*
- c) Is separately investigated when forming part of another component, provided the component is used within its established ratings and limitations.*

*Exception No. 2: A component that complies with a UL component standard other than those specified in [6.2](#) – [6.22](#) is acceptable if:*

- a) The component also complies with the applicable component standard specified in [6.2](#) – [6.22](#); or*
- b) The component standard:*
  - 1) Is compatible with the ampacity and overcurrent protection requirements in the National Electrical Code, ANSI/NFPA 70, where applicable;*
  - 2) Considers long-term thermal properties of polymeric insulating materials in accordance with the Standard for Polymeric Materials – Long Term Property Evaluations, UL 746B; and*
  - 3) Any use limitations of the other component UL standards are identified and appropriately accommodated in the end use application. For example, a component used in a household application, but intended for industrial use and that complies with the relevant component standard may assume user expertise not common in household applications.*

6.1.2 Specific components are incomplete in construction features or restricted in performance capabilities. Such components are intended for use only under limited conditions, such as certain temperatures not exceeding specified limits, and shall be used only under those specific conditions.

6.1.3 A component that is also intended to perform other functions, such as over current protection, ground-fault circuit-interruption, surge suppression, any other similar functions, or any combination thereof, shall comply additionally with the requirements in the applicable UL standard(s) that cover devices that provide those functions.

*Exception: Where these other functions are not required for the application and not identified as part of markings, instructions, or packaging for the appliance, the additional component UL standard(s) need not be applied.*

6.1.4 A component not anticipated by the requirements in this end product standard, not specifically covered by the component standards in [6.2](#) – [6.22](#), and that involves a risk of fire, electric shock, or injury to persons, shall be additionally investigated in accordance with the applicable UL standard, and shall comply with [6.1.1](#) (b) – (d).

6.1.5 With regard to a component being additionally investigated, reference to construction and performance requirements in another UL end product standard is applicable where that standard anticipates normal and abnormal use conditions consistent with the application of this end product standard.

## 6.2 Attachment plugs, receptacles, connectors, and terminals

6.2.1 Attachment plugs, receptacles, appliance couplers, appliance inlets (motor attachment plugs), and appliance (flatiron) plugs, shall comply with the Standard for Attachment Plugs and Receptacles, UL 498. See [6.2.8](#).

*Exception No. 1: Attachment plugs and appliance couplers integral to cord sets or power supply cords that are investigated in accordance with the requirements in the Standard for Cord Sets and Power Supply Cords, UL 817 are not required to comply with UL 498.*

*Exception No. 2: A fabricated pin terminal assembly(ies) need not comply with UL 498 if it complies with Live Parts, Section [14](#), Insulating Material, Section [17](#), and Spacings, Section [23](#), of this end product standard.*

6.2.2 Quick-connect terminals, both connectors and tabs, for use with one or two 22 – 10 AWG copper conductors, having nominal widths of 2.8, 3.2, 4.8, 5.2, and 6.3 mm (0.110, 0.125, 0.187, 0.205, and 0.250 in), intended for internal wiring connections in appliances, or for the field termination of conductors to appliance, shall comply with the Standard for Electrical Quick-Connect Terminals, UL 310.

*Exception: Other sizes of quick-connect terminals shall be investigated with respect to crimp pull out, insertion-withdrawal, temperature rise, and all tests shall be conducted in accordance with UL 310.*

6.2.3 Single and multipole connectors for use in data, signal, control and power applications within and between electrical equipment, and that are intended for factory assembly to copper or copper alloy conductors, or for factory assembly to printed wiring boards, shall comply with the Standard for Component Connectors for Data, Signal, Control and Power Applications, UL 1977. See [6.2.8](#).

6.2.4 Wire connectors shall comply with the Standard for Wire Connectors, UL 486A-486B.

6.2.5 Splicing wire connectors shall comply with the Standard for Splicing Wire Connectors, UL 486C.

6.2.6 Multi-pole splicing wire connectors that are intended to facilitate the connection of hard-wired utilization equipment to the branch-circuit conductors of buildings shall comply with the Standard for Insulated Multi-Pole Splicing Wire Connectors, UL 2459. See [6.2.9](#).

6.2.7 Equipment wiring terminals for use with all alloys of copper, aluminum, or copper-clad aluminum conductors, shall comply with the Standard for Equipment Wiring Terminals for Use with Aluminum and/or Copper Conductors, UL 486E.

6.2.8 Terminal blocks shall comply with the Standard for Terminal Blocks, UL 1059, and, if applicable, be suitably rated for field wiring.

*Exception: A fabricated part performing the function of a terminal block need not comply with UL 1059 if the part complies with the requirements in Live Parts, Section [14](#), Insulating Material, Section [17](#), and Spacings, Section [23](#), of this end product standard. This exception does not apply to protective conductor terminal blocks.*

6.2.9 Female devices (such as receptacles, appliance couplers, and connectors) that are intended, or that may be used, to interrupt current in the end product, shall be suitably rated for current interruption of the specific type of load, when evaluated with its mating plug or connector. For example, an appliance coupler that can be used to interrupt the current of a motor load shall have a suitable horsepower rating when tested with its mating plug.

### 6.3 Batteries

6.3.1 Rechargeable lithium ion (Li-ion) cells shall comply with the requirements for secondary lithium cells Specified in the Standard for Lithium Batteries, UL 1642.

### 6.4 Boxes and raceways

6.4.1 Electrical boxes and the associated bushings and fittings, and raceways, of the types specified in Chapter 3, Wiring Methods and Materials, of the National Electrical Code, ANSI/NFPA 70 and that comply with the relevant UL standard (such as the Standard for Metallic Outlet Boxes, UL 514A, the Standard for Nonmetallic Outlet Boxes, Flush-Devices Boxes and Covers, UL 514C, the Standard for Cover Plates for Flush-Mounted Wiring Devices, UL 514D) and [6.1](#) are considered to comply with the requirements in this end product standard.

### 6.5 Capacitors and filters

6.5.1 The component requirements for a capacitor are not specified. A capacitor that complies with the Standard for Capacitors, UL 810, is considered to comply with the requirements in [22.1](#).

6.5.2 Electromagnetic interference filters with integral enclosures that comply with the Standard for Electromagnetic Interference Filters, UL 1283, are considered to comply with the requirements in [22.1](#).

### 6.6 Controls

#### 6.6.1 General

6.6.1.1 Auxiliary controls shall be evaluated using the applicable requirements in this end product standard and the requirements in the Controls – End Product Test Parameters, Section [34](#).

6.6.1.2 Operating (regulating) controls shall be evaluated using the applicable component standard requirements specified in [6.6.2](#) – [6.6.7](#) and if applicable, the requirements in Controls – End Product Test Parameters, Section [34](#), unless otherwise specified in this end product standard.

6.6.1.3 Operating controls that rely upon software for the normal operation of the end product where deviation or drift of the control may result in a risk of fire, electric shock, or injury to persons, such as a speed control unexpectedly changing its output, shall comply with one or both of the following standards:

- a) The Standard for Tests for Safety-Related Controls Employing Solid-State Devices, UL 991, and the Standard for Software in Programmable Components, UL 1998; or
- b) The Standard for Automatic Electrical Controls for Household and Similar Use; Part 1: General Requirements, UL 60730-1.

6.6.1.4 Protective (limiting) controls shall be evaluated using the applicable component standard requirements specified in [6.6.2](#) – [6.6.7](#) and if applicable, the parameters in Controls – End Product Test Parameters, Section [34](#), unless otherwise specified in this end product standard.

6.6.1.5 Solid-state protective controls that do not rely upon software as a protective component shall comply with one or both of the following standards:

- a) The Standard for Tests for Safety-Related Controls Employing Solid-State Devices, UL 991; or
- b) The Standard for Automatic Electrical Controls for Household and Similar Use; Part 1: General Requirements, UL 60730-1, except for the Controls Using Software requirements.

6.6.1.6 Protective controls that rely upon software as a protective component shall comply with one or both of the following standards:

- a) The Standard for Tests for Safety-Related Controls Employing Solid-State Devices, UL 991; and Standard for Software in Programmable Components, UL 1998; or
- b) The Standard for Automatic Electrical Controls for Household and Similar Use; Part 1: General Requirements, UL 60730-1.

6.6.1.7 An electronic, non-protective control that is simple in design need only be subjected to the applicable requirements in this end-product standard. A control that does not include an integrated circuit or microprocessor, but does consist of a discrete switching device, capacitors, transistors, or resistors is considered simple in design. See Abnormal Operation Tests, Section [64](#).

## 6.6.2 Electromechanical and electronic controls

6.6.2.1 A control, other than as specified in [6.6.2](#) – [6.6.7](#), shall comply with one of the following:

- a) The Standard for Solid-State Controls for Appliances, UL 244A;
- b) The Standard for Temperature-Indicating and -Regulating Equipment, UL 873; or
- c) The Standard for Automatic Electrical Controls for Household and Similar Use; Part 1: General Requirements, UL 60730-1.

## 6.6.3 Liquid level controls

6.6.3.1 A liquid level control shall comply with one of the following:

- a) The Standard for Solid-State Controls for Appliances, UL 244A;
- b) The Standard for Temperature-Indicating and -Regulating Equipment, UL 873;
- c) The Standard for Industrial Control Equipment, UL 508; or
- d) The Standard for Automatic Electrical Controls for Household and Similar Use; Part 1: General Requirements, UL 60730-1, and;
  - 1) The Standard for Automatic Electrical Controls for Household and Similar Use; Part 2: Particular Requirements for Automatic Electrical Water Level Controls of the Float Type for Household and Similar Applications, UL 60730-2-16; or
  - 2) The Standard for Automatic Electrical Controls for Household and Similar Use; Part 2: Particular Requirements for Automatic Electrical Water and Air Flow Sensing Controls, Including Mechanical Requirements, UL 60730-2-18.

## 6.6.4 Motor and speed controls

6.6.4.1 A control used to start, stop, regulate or control the speed of a motor shall comply with one of the following:

- a) The Standard for Solid-State Controls for Appliances, UL 244A;
- b) The Standard for Temperature-Indicating and -Regulating Equipment, UL 873;
- c) The Standard for Industrial Control Equipment, UL 508;

d) The Standard for Adjustable Speed Electrical Power Drive Systems – Part 5-1: Safety Requirements – Electrical, Thermal, and Energy, UL 61800-5-1; or

e) The Standard for Automatic Electrical Controls for Household and Similar Use; Part 1: General Requirements, UL 60730-1.

### 6.6.5 Pressure controls

6.6.5.1 A pressure control shall comply with one of the following:

a) The Standard for Temperature-Indicating and -Regulating, UL 873;

b) The Standard for Industrial Control Equipment, UL 508; or

c) The Standard for Automatic Electrical Controls for Household and Similar Use; Part 1: General Requirements, UL 60730-1; and the Standard for Automatic Electrical Controls for Household and Similar Use; Part 2: Particular Requirements for Automatic Electrical Pressure Sensing Controls Including Mechanical Requirements, UL 60730-2-6.

### 6.6.6 Temperature controls

6.6.6.1 A temperature control shall comply with one of the following:

a) The Standard for Solid-State Controls for Appliances, UL 244A;

b) The Standard for Temperature-Indicating and -Regulating Equipment, UL 873;

c) The Standard for Industrial Control Equipment, UL 508; or

d) The Standard for Automatic Electrical Controls for Household and Similar Use; Part 1: General Requirements, UL 60730-1; and the Standard for Automatic Electrical Controls for Household and Similar Use; Part 2: Particular Requirements for Temperature Sensing Controls, UL 60730-2-9.

6.6.6.2 A temperature positive temperature coefficient (PTC) or a negative temperature coefficient (NTC) thermistor, that performs the same function as an operating or protective control shall comply with the Standard for Thermistor-Type Devices, UL 1434.

6.6.6.3 A thermal cutoff shall comply with the Standard for Thermal-Links – Requirements and Application Guide, UL 60691.

### 6.6.7 Timer controls

6.6.7.1 A timer control shall comply with one of the following:

a) The Standard for Solid-State Controls for Appliances, UL 244A; or

b) The Standard for Automatic Electrical Controls for Household and Similar Use; Part 1: General Requirements, UL 60730-1; and the Standard for Automatic Electrical Controls for Household and Similar Use; Part 2: Particular Requirements for Timers and Time Switches, UL 60730-2-7.

## 6.7 Cords, cables, and internal wiring

6.7.1 A cord set or power supply cord shall comply with the Standard for Cord Sets and Power Supply Cords, UL 817.

6.7.2 Flexible cords and cables shall comply with the Standard for Flexible Cords and Cables, UL 62. Flexible cord and cables are considered to comply with this requirement when pre-assembled in a cord set or power supply cord that complies with the Standard for Cord Sets and Power Supply Cords, UL 817.

6.7.3 Internal wiring composed of insulated conductors shall comply with the Standard for Appliance Wiring Material, UL 758.

*Exception No. 1: Insulated conductors need not comply with UL 758 if they comply with one of the following:*

- a) *The Standard for Thermoset-Insulated Wires and Cables, UL 44;*
- b) *The Standard for Thermoplastic-Insulated Wires and Cables, UL 83;*
- c) *The Standard for Fixture Wire, UL 66; or*
- d) *The applicable UL standard(s) for other insulated conductor types specified in Chapter 3, Wiring Methods and Materials, of the National Electrical Code, ANSI/NFPA 70.*

*Exception No. 2: Insulated conductors for specialty applications (e.g. data processing or communications) and located in a low-voltage circuit not involving the risk of fire, electric shock or injury to persons need not comply with UL 758.*

## **6.8 Cord reels**

6.8.1 A cord reel shall comply with special use cord reel requirements in the Standard for Cord Reels, UL 355.

## **6.9 Film-coated wire (magnet wire)**

6.9.1 The component requirements for film coated wire and Class 105 (A) insulation systems are not specified.

6.9.2 Film coated wire in intimate combination with one or more insulators, and incorporated in an insulation system rated Class 120 (E) or higher, shall comply with the magnet wire requirements in the Standard for Systems of Insulating Materials – General, UL 1446.

## **6.10 Ground-fault, arc-fault, and leakage current detectors/interrupters**

6.10.1 Ground-fault circuit-interrupters (GFCI) for protection against electrical shock shall comply with the Standard for Ground-Fault Circuit-Interrupters, UL 943. The following statement, or equivalent, shall be included as a marking near the GFCI, or as an instruction in the manual: "Press the TEST button (then RESET button) every month to assure proper operation."

6.10.2 Appliance-leakage-current interrupters (ALCI) for protection against electrical shock shall comply with the Standard for Appliance-Leakage-Current Interrupters, UL 943B.

6.10.3 With respect to [6.11.2](#), an ALCI is not considered an acceptable substitute for a GFCI when the National Electrical Code, ANSI/NFPA 70 requires a GFCI.

6.10.4 Equipment ground-fault protective devices shall comply with the Standard for Ground-Fault Sensing and Relaying Equipment, UL 1053, and the applicable requirements in the Standard for Ground-Fault Circuit-Interrupters, UL 943.

6.10.5 Arc-fault circuit-interrupters (AFCI) shall comply with the Standard for Arc-Fault Circuit-Interrupters, UL 1699.

6.10.6 Leakage-current detector-interrupters (LCDI) and any shielded cord between the LCDI and appliance shall comply with the Standard for Arc-Fault Circuit-Interrupters, UL 1699.

## 6.11 Insulation systems

6.11.1 Materials used in an insulation system that operates above Class 105 (A) temperatures shall comply with the Standard for Systems of Insulating Materials – General, UL 1446.

6.11.2 All insulation systems employing integral ground insulation shall comply with the requirements specified in the Standard for Systems of Insulating Materials – General, UL 1446.

## 6.12 Light sources and associated components

6.12.1 Lampholders and indicating lamps shall comply with the Standard for Lampholders, UL 496.

*Exception: Lampholders forming part of a luminaire that complies with the applicable UL luminaire standard are considered to comply with this requirement.*

6.12.2 Lighting ballasts shall comply with one of the following:

- a) The Standard for Fluorescent-Lamp Ballasts, UL 935; or
- b) The Standard for High-Intensity Discharge Lamp Ballasts, UL 1029.

*Exception No. 1: Ballasts forming part of a luminaire that complies with an applicable UL luminaire standard are considered to comply with this requirement.*

*Exception No. 2: Ballasts for other light sources shall comply with the applicable UL standard(s).*

6.12.3 Light emitting diode (LED) light sources shall comply with the Standard for Light Emitting Diode (LED) Equipment For Use In Lighting Products, UL 8750.

*Exception No. 1: LED light sources forming part of a luminaire that complies with an applicable UL luminaire standard are considered to comply with this requirement.*

*Exception No. 2: Individual LED light sources mounted on printed wiring boards and intended for indicating purposes need not comply with UL 8750, but shall comply with the applicable requirements in this end product standard.*

## 6.13 Marking and labeling systems

6.13.1 A marking and labeling system shall comply with the Standard for Marking and Labeling Systems, UL 969. Requirements include standard atmosphere, oil, and oven conditioning.

*Exception: A label on a tool that is only intended to be used for wood-working and that is not shipped with an oil coating is not required to be evaluated for oil.*

## 6.14 Motors and motor overload protection

### 6.14.1 General

6.14.1.1 General-purpose type motors having a NEMA frame size shall comply with the requirements specified in [6.14.2](#) or [6.14.3](#). This includes fractional HP motors rated up to 1 HP (typically NEMA frame sizes 42, 48, or 56), and integral HP motors rated 1 HP and greater (typically NEMA frame sizes 140 – 449T).

6.14.1.2 Component type motors shall comply with the requirements specified in [6.14.2](#) or [6.14.3](#).

6.14.1.3 Motors located in a low voltage circuit are evaluated for the risk of fire, electric shock, or injury to persons in accordance with the applicable requirements in this end product standard.

6.14.1.4 Low voltage component fans that comply with the Standard for Electric Fans, UL 507, are considered to comply with the requirements for Motors, Section [18](#).

### 6.14.2 General-purpose type motors

6.14.2.1 A general-purpose type motor shall comply with the Standard for Rotating Electrical Machines – General Requirements, UL 1004-1.

### 6.14.3 Component type motors

6.14.3.1 Component type motors shall comply with either [6.14.3.2](#) or [6.14.3.3](#).

6.14.3.2 The motor shall comply with the Standard for Rotating Electrical Machines – General Requirements, UL 1004-1 except as noted in [Table 6.1](#).

**Table 6.1**  
**Superseded requirements**

UL 1004-1 Exempted Requirement	Superseded by UL 987 Requirements
Current and Horsepower Relation, Section 6	Paragraph <a href="#">56.3</a>
Cord-Connected Motors, Section 15	Section <a href="#">13.1</a>
Factory Wiring Terminals and Leads, Section 17	Section <a href="#">15</a>
Electrical Insulation, Section 22	Section <a href="#">17</a>
Non-Metallic Functional Parts, Section 28	Sections <a href="#">7</a> , <a href="#">17</a> , <a href="#">18</a>
Solid-State Controls, 7.2	Section <a href="#">6.6</a>
Non-metallic enclosure thermal aging, 9.1.4	Section <a href="#">7.2</a>
Motor enclosure, 9.2 – 9.4	Section <a href="#">7</a>
Grounding, Sections 10 and 11	Section <a href="#">24</a>
Ventilation Openings, Section 12: only applicable where the openings are on surfaces considered to be the appliance enclosure.	Sections <a href="#">8</a> and <a href="#">9</a>
Accessibility of Uninsulated Live Parts, Film-Coated Wire, and Moving Parts, Section 13	Sections <a href="#">8</a> and <a href="#">9</a>
Protection Against Corrosion, Section 14	Section <a href="#">11</a>

Table 6.1 Continued on Next Page

Table 6.1 Continued

UL 1004-1 Exempted Requirement	Superseded by UL 987 Requirements
Available fault current ratings for motor start and running capacitors, Paragraph 26.6: not applicable for cord and plug connected appliances.	Section <a href="#">22</a>
Switch, Section 27 is not applicable to centrifugal starting switches	Section <a href="#">19</a>
With the exception of Sections 35 and 40 (Resilient Elastomer Mounting and Electrolytic Capacitor Tests, respectively), the performance tests in the Standard for Rotating Electrical Machines – General Requirements, UL 1004-1 are not applicable	All applicable performance tests
Only the following marking requirements specified in 43.1 of UL 1004-1 are applicable: manufacturer's name or identification; rated voltage; rated frequency; number of phases if greater than 1; and multi-speed motors, other than a shaded-pole or a permanent-split-capacitor motor, shall be marked with the amperes and horsepower at each speed	Paragraph <a href="#">80.1</a>

6.14.3.3 The motor shall comply with the applicable component requirements for Components, Section [6](#), the following construction requirements, and the applicable performance requirements (when tested in conjunction with the end product), of this end product standard:

- a) Protection Against Corrosion, Section [11](#);
- b) Wiring Compartments, Section [12.2](#);
- c) Internal Wiring, Section [15](#);
- d) Insulating Material, Section [17](#);
- e) Motors, Section [18](#);
- f) Capacitors, Section [22](#);
- g) Spacings, Section [23](#); and
- h) Grounding, Section [24](#).

#### 6.14.4 Motor overload protection

6.14.4.1 Thermal protection devices integral with the motor shall comply with one of the following:

- a) The Standard for Overheating Protection for Motors, UL 2111;
- b) The Standard for Thermally Protected Motors, UL 1004-3; or
- c) The Standard for Automatic Electrical Controls for Household and Similar Use; Part 1: General Requirements, UL 60730-1; and the Standard for Automatic Electrical Controls for Household and Similar Use; Part 2 Particular Requirements for Thermal Motor Protectors, UL 60730-2-2; in conjunction with the Standard for Thermally Protected Motors, UL 1004-3 (to evaluate the motor-protector combination).

6.14.4.2 Impedance protection shall comply with the Standard for Impedance Protected Motors, UL 1004-2.

6.14.4.3 Electronic protection integral to the motor shall comply with the Standard for Electronically Protected Motors, UL 1004-7.

6.14.4.4 Except as indicated in [6.14.4.3](#), electronically protected motor circuits shall comply with one of the following. See Motor and Speed Controls, Section [6.6.4](#), for basic control requirements.

a) The Standard for Tests for Safety-Related Controls Employing Solid-State Devices, UL 991. When the protective electronic circuit is relying upon software as a protective component, it shall comply with the requirements in the standard for tests for Software in Programmable Components, UL 1998. If software is relied upon to perform a safety function, it shall be considered software Class 1;

b) The Standard for Automatic Electrical Controls for Household and Similar Use; Part 1: General Requirements, UL 60730-1; If software is relied upon to perform a safety function, it shall be considered software Class B; or

c) The Standard for Adjustable Speed Electrical Power Drive Systems – Part 5-1: Safety Requirements – Electrical, Thermal, and Energy, UL 61800-5-1.

*Exception: Compliance with the above standards is not required for an electronically protected motor circuit if there is no risk of fire, electric shock, or injury to persons during abnormal testing with the motor electronic circuit rendered ineffective; compliance with the applicable requirements in this end product standard is then required.*

## 6.15 Overcurrent protection

6.15.1 Fuses shall comply with the Standard for Low-Voltage Fuses – Part 1: General Requirements, UL 248-1; and the applicable UL 248 Part 2 (e.g. UL 248-5). Defined use fuses that comply with UL 248-1 and another applicable UL standard for fuses are considered to comply with this requirement.

6.15.2 Fuseholders shall comply with Standard for Fuseholders – Part 1: General Requirements, UL 4248-1, and the applicable Part 2 (e.g. UL 4248-9).

6.15.3 Circuit breakers shall comply with the Standard for Molded-Case Circuit Breakers, Molded-Case Switches and Circuit-Breaker Enclosures, UL 489.

*Exception: Circuit breakers used in telecommunications circuitry that comply with the Standard for Circuit Breakers For Use in Communications Equipment, UL 489A, need not comply with UL 489.*

6.15.4 Circuit breakers having integral ground fault circuit interrupter capability for protection against electrical shock shall additionally comply with the Standard for Ground-Fault Circuit-Interrupters, UL 943.

6.15.5 Supplementary protectors shall comply with the Standard for Supplementary Protectors for Use in Electrical Equipment, UL 1077.

6.15.6 Fusing resistors shall comply with the Standard for Fusing Resistors and Temperature-Limited Resistors for Radio- and Television-Type Appliances, UL 1412.

## 6.16 Polymeric materials and enclosures

6.16.1 Unless otherwise specified in this end product standard, polymeric electrical insulating materials and enclosures shall comply with the applicable requirements in the Standard for Polymeric Materials – Use in Electrical Equipment Evaluations, UL 746C.

6.16.2 Metallized or painted polymeric parts or enclosures shall comply with the applicable requirements in the Standard for Polymeric Materials – Use in Electrical Equipment Evaluations, UL 746C. This requirement is not applicable to exterior surfaces of polymeric enclosure materials or parts provided that the metallized coating or paint does not offer a continuous path for an internal flame to propagate externally.

### 6.17 Power supplies

6.17.1 A Class 2 power supply shall comply the Standard for Class 2 Power Units, UL 1310.

6.17.2 A non-Class 2 power supply shall comply with the Standard for Power Units Other Than Class 2, UL 1012.

### 6.18 Printed wiring boards

6.18.1 Printed wiring boards, including the coatings, shall comply with the Standard for Printed Wiring Boards, UL 796.

*Exception: A printed-wiring board in a Class 2 nonsafety circuit is not required to comply with the bonding requirements in UL 796 if the board is separated from parts of other circuits such that loosening of the bond between the foil conductor and the base material will not result in the foil conductors or components coming in contact with parts of other circuits of the control or of the end-use product.*

6.18.2 A printed-wiring board containing circuitry in a line-connected circuit or a safety circuit shall comply with the direct-support of live parts requirements.

6.18.3 Unless otherwise specified, a printed-wiring board shall have a minimum flame classification of V-2.

*Exception: A printed-wiring board located in a secondary circuit that complies with the requirements for Class 2 or limited voltage/current circuits have a minimum flame Class of HB.*

### 6.19 Semiconductors and small electrical and electronic components

6.19.1 A power switching semiconductor device that is relied upon to provide isolation to ground shall comply with the Standard of Safety for Electrically Isolated Semiconductor Devices, UL 1557.

6.19.2 An optical isolator that is relied upon to provide isolation between primary and secondary circuits or between other circuits as required by this end product standard shall comply with the Standard for Safety for Optical Isolators, UL 1577.

6.19.3 Except as otherwise specified in this standard, component requirements are not specified for small electrical parts on printed wiring boards, including diodes, transistors, resistors, inductors, integrated circuits, and capacitors not directly connected to the supply source.

6.19.4 Where an electronic component is determined to be a critical component during the Abnormal Operation Test, Section [64](#) in this standard, the circuit shall comply with one or both of the following standards. See Protective Controls (Limiting Controls), Section [34.4](#) for the test parameters to be used.

- a) The Standard for Tests for Safety-Related Controls Employing Solid-State Devices, UL 991, including its Follow-Up Program; and as applicable, the Standard for Software in Programmable Components, UL 1998 for controls that rely upon software as a protective component; or

b) The Standard for Automatic Electrical Controls for Household and Similar Use; Part 1: General Requirements, UL 60730-1.

6.19.5 A critical component is a component that performs one or more safety-related functions whose failure results in a condition, such as the risk of fire, electric shock, or injury to persons, in the end-product application.

6.19.6 A critical component may also be identified using a failure-mode and effect analysis (FMEA) in accordance with the Failure-Mode and Effect Analysis (FMEA) requirements in the Standard for Tests for Safety-Related Controls Employing Solid-State Devices, UL 991.

6.19.7 Portions of a circuit comprised of a microcontroller or other programmable device that performs a back-up, limiting, or other safety function intended to reduce the risk of fire, electric shock, or injury to persons shall comply with the Controls Using Software requirements in the Standard for Automatic Electrical Controls for Household and Similar Use; Part 1: General Requirements, UL 60730-1, Annex H.

## 6.20 Supplemental insulation, insulating bushings, and assembly aids

6.20.1 The requirements for supplemental insulation (e.g. tape, sleeving or tubing) are not specified unless the insulation or device is required to comply with a performance requirement of this standard. In such cases, the insulation or device shall comply with the following applicable standards:

- a) Insulating tape shall comply with the Standard for Polyvinyl Chloride, Polyethylene, and Rubber Insulating Tape, UL 510;
- b) Sleeving shall comply with the Standard for Coated Electrical Sleeving, UL 1441; or
- c) Tubing shall comply with the Standard for Extruded Insulating Tubing, UL 224.

6.20.2 Wire positioning devices required to comply with the requirements in this end product standard shall comply with the Standard for Positioning Devices, UL 1565.

6.20.3 Insulating bushings shall comply with the Standard for Insulating Bushings, UL 635 and be suitable for the application with respect to the hole size and shape, maximum use temperature and wire size or type. To determine if the hole size and shape is suitable for the bushing, the applicable test(s) specified in this standard (e.g. Strain Relief Test, Section 59, Push-Back Relief Test, Section 60, Thermal Stability Test, Section 70.10) shall be conducted.

## 6.21 Switches

6.21.1 Switches shall comply with one of the following, as applicable:

- a) The Standard for Special-Use Switches, UL 1054;
- b) The Standard for Switches for Appliances – Part 1: General Requirements, UL 61058-1;
- c) The Standard for General-Use Snap Switches, UL 20; or
- d) The Standard for Nonindustrial Photoelectric Switches for Lighting Control, UL 773A.

*Exception: Switching devices that comply with the applicable UL standards for specialty applications (e.g. transfer switch equipment), industrial use (e.g. contactors, relays, auxiliary devices), or are integral to another component (e.g. switched lampholder) need not comply with this requirement.*

6.21.2 Clock-operated switches, and time switches, including timers, shall comply with one of the following:

- a) The Standard for Clock-Operated Switches, UL 917; or
- b) The Standard for Automatic Electrical Controls for Household and Similar Use; Part 1: General Requirements, UL 60730-1, and the Standard for Automatic Electrical Controls for Household and Similar Use; Part 2: Particular Requirements for Timers and Time Switches, UL 60730-2-7.

6.21.3 A timer or time switch, incorporating electronic timing circuits or switching circuits, with or without separable contacts, that functions as a protective control, shall comply with the requirements for a protective control. See [6.6.1.3](#).

## 6.22 Transformers

6.22.1 General-purpose transformers shall comply with the Standard for Low Voltage Transformers – Part 1: General Requirements, UL 5085-1; and the Standard for Low Voltage Transformers – Part 2: General Purpose Transformers, UL 5085-2.

*Exception: A transformer that complies with the Standard for Transformers and Motor Transformers for Use in Audio-, Radio-, and Television-Type Appliances, UL 1411, and that is used in a circuit involving an audio or video component complies with the intent of this requirement.*

6.22.2 Class 2 and Class 3 transformers shall comply with the Standard for Low Voltage Transformers – Part 1: General Requirements, UL 5085-1; and the Standard for Low Voltage Transformers – Part 3: Class 2 and Class 3 Transformers, UL 5085-3.

*Exception: Transformers located in a low voltage circuit, and that do not involve a risk of fire, electric shock or injury to persons need not comply with this requirement.*

## 7 Frame and Enclosure

### 7.1 General

7.1.1 A tool shall be formed and assembled so that it will have the strength and rigidity necessary to resist the abuses to which it is likely to be subjected, without increasing the risk of fire, electric shock, or injury to persons due to total or partial collapse with resulting reduction of spacings, loosening or displacement of parts, or other serious defects.

### 7.2 Enclosures of metallic materials

7.2.1 Cast-metal portions of an enclosure shall not be thinner than the minimum acceptable values specified in [Table 7.1](#).

**Table 7.1**  
**Minimum acceptable thickness of a cast metal enclosure**

Metal	Flat surfaces		Curved, ribbed, or otherwise reinforced surfaces, and surfaces having a size or shape providing the required mechanical strength,	
	Inch	(mm)	Inch	(mm)
Die-cast metal	5/64	(2.0)	3/64	(1.2)
Cast malleable iron	3/32	(2.4)	1/16	(1.6)
Other cast metal	1/8	(3.2)	3/32	(2.4)

7.2.2 Among the factors to be considered when judging an enclosure of sheet metal shall be the size, shape, and thickness of the metal all with respect to the application and intended use of the tool.

7.2.3 Among the factors to be considered when judging an enclosure of magnesium shall be the combustibility and resistance to arcing of the metal.

7.2.4 Sheet metal to which a wiring system is intended to be connected in the field shall have a thickness not less than the minimum acceptable value specified in [Table 7.2](#).

**Table 7.2**  
**Minimum acceptable thickness of a sheet metal surface to which a wiring system is intended to be connected in the field**

Metal	Surfaces to which a wiring system is intended to be connected in the field	
	Inch	(mm)
Uncoated sheet steel	0.032	(0.81)
Galvanized sheet steel	0.034	(0.86)
Sheet aluminum	0.045	(1.14)
Sheet copper or brass	0.045	(1.14)

### 7.3 Enclosures of polymeric materials

7.3.1 Polymeric material used for the enclosure of a cord-connected tool that requires operator attendance while work is being done shall comply with the requirements in [7.3.3](#) and [67.1](#) and with the requirements for Polymeric Materials, Section [69](#) or [70](#), whichever is applicable.

7.3.2 Polymeric material used for the enclosure of a tool that is intended for permanent connection to the power supply or a tool that may be operated unattended shall comply with:

- a) The requirement in [7.3.3](#) and [67.1](#) and with the requirements for Polymeric Materials, Section [69](#) or [70](#), whichever is applicable; and
- b) Any additional examination and test needed to evaluate the material for use in the application.

7.3.3 A polymeric material used for the enclosure of a tool shall be resistant to thermal degradation at the maximum temperature to which it is exposed during its normal use.

7.3.4 With reference to [7.3.3](#), a polymeric material is considered to be resistant to thermal degradation at the temperatures to which it will be exposed if:

- a) The material has a temperature index, based on historical data or a long-term thermal aging program, more than the maximum temperature to which it is exposed during its normal use;
- b) The maximum temperature to which the material is exposed during normal use does not exceed 65°C (149°F); or
- c) The maximum temperature to which the material is exposed during normal use does not exceed 95°C (203°F), and the material complies with the requirement for Tests of Polymeric Enclosures Following Oven Conditioning, Section [68](#).

## 8 Accessibility of Live Parts

8.1 An electrical part of a tool shall be located or enclosed so that the likelihood of unintentional contact with an uninsulated live part will be reduced. Insulated brush caps do not require additional enclosure.

8.2 With reference to the requirement in [8.1](#), the enclosure of a tool shall have no openings, other than those required for normal use of the tool, which will permit the finger probe, illustrated in [Figure 8.1](#), to contact any uninsulated live part or film-coated wire when applied in any direction.

ULNORM.COM : Click to view the full PDF of UL 987-2020

**Figure 8.1**  
**IEC articulate probe**

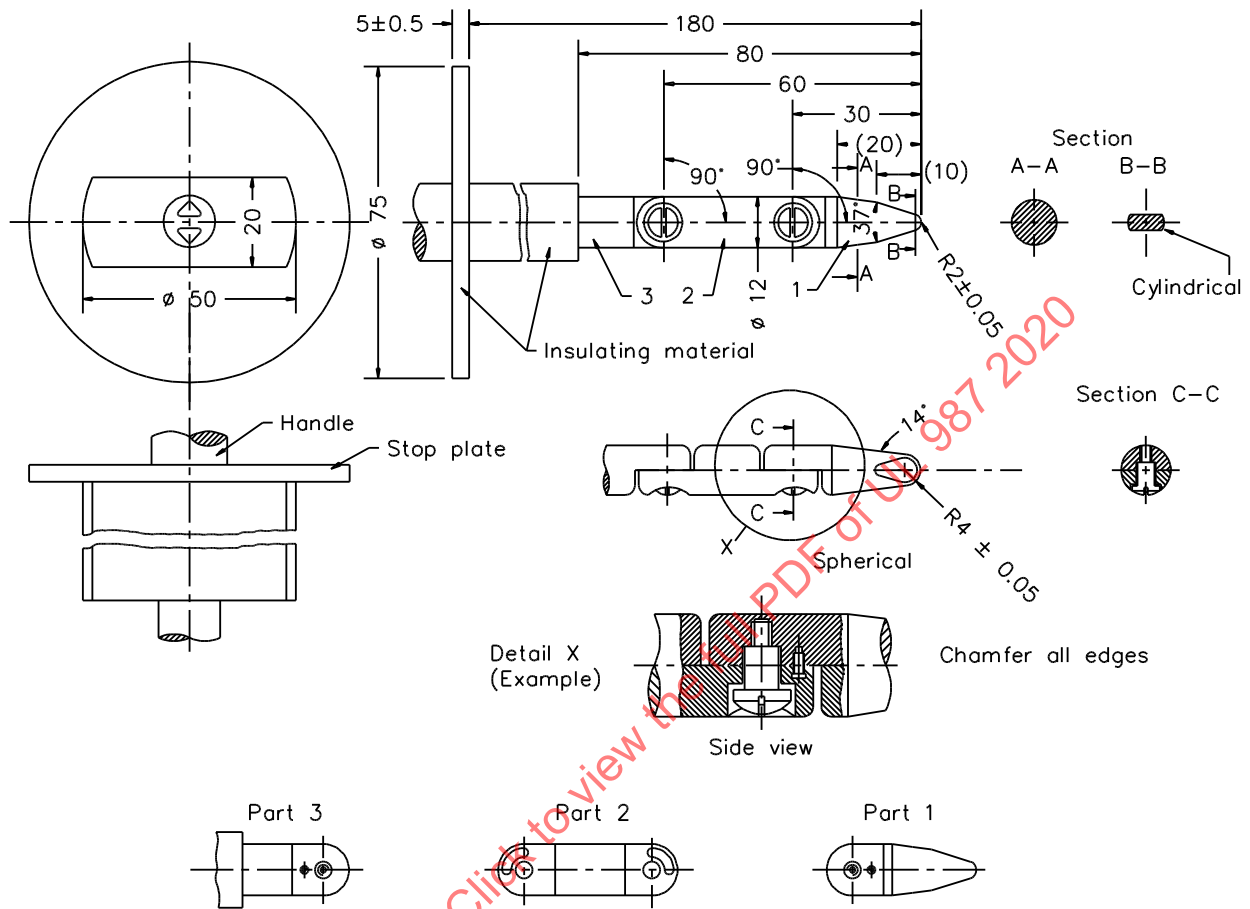

SA1788A

Linear dimensions in millimeters

Tolerances on dimensions without specific tolerance:

on angles: +0', -10'

on linear dimensions:

up to 25 mm: +0 mm, -0.05 over 25 mm: ±0.2 mm

Material of finger: for example heat-treated steel

Both joints of this finger may be bent through an angle of 90°, with a 0 to +10° tolerance, but in one and the same direction only.

Using the pin and groove solution is only one of the possible approaches in order to limit the bending angle to 90°. For this reason dimensions and tolerances of these details are not given in the drawing. The actual design must ensure a 90° bending angle with a 0 to +10° tolerance.

8.3 In a double-insulated tool, a test pin as illustrated in [Figure 8.2](#), when inserted point first into an opening in an enclosure housing, shall not contact any parts separated from live parts by basic insulation only.

8.4 During the examination of a tool in connection with the requirement in [8.2](#) and [8.3](#), a part of the outer enclosure that is intended to be removed without the use of a tool by the user – to permit the attachment of an accessory, to allow access to means for making an operating adjustment, or for a similar reason – is to be disregarded; that is, such a part is not considered to reduce the risk of electric shock.

8.5 If removal of a guard or a cover is necessary for mounting a motor shipped detached from a tool, the guard or cover shall be constructed so that it cannot be replaced improperly.

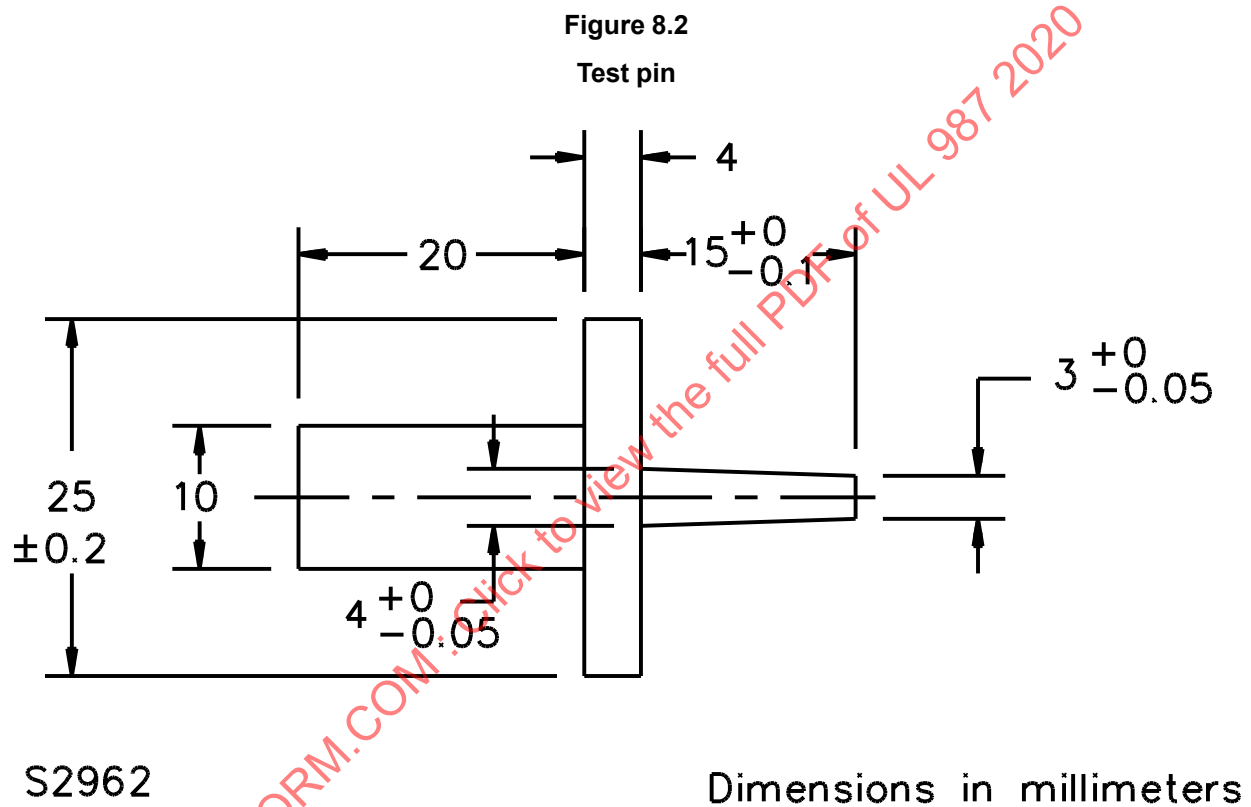

## 9 Exclusion of Foreign Matter

9.1 The enclosure of a tool, a control unit, or an auxiliary component, such as a rheostat or a rectifier, that is not integral with the tool shall exclude foreign matter, including abrasive or electrically conductive particles, that is likely to be present during operation and that may:

- a) Adversely affect electrical insulation – for example, by build-up of a leakage path over an insulating surface; or
- b) Otherwise result in a risk of fire or electric shock.

9.2 All uninsulated live parts and film-coated wire in a grinder shall be completely enclosed.

*Exception: The following are acceptable for a grinder with provision for grounding:*

- a) An opening in a horizontal bottom surface of a bench grinder;
- b) An opening in a vertical skirt of a bench grinder entirely below an opening specified in (a) above;
- c) An opening in a vertical skirt of a bench grinder below an opening in a curved bottom surface;  
and
- d) An opening in the enclosure of a grinder other than a bench grinder if protection equivalent to that for a bench grinder is provided.

## 10 Mechanical Assembly

10.1 A tool assembled by the manufacturer or in accordance with the manufacturer's specifications, shall not be adversely affected by the vibration during its intended operation.

10.2 A brush cap shall be tightly threaded or otherwise designed and secured to reduce the likelihood of unexpected loosening.

10.3 A switch, a lampholder, an attachment-plug receptacle, a motor-attachment plug, or a similar component shall be mounted securely, and shall be prevented from turning or shifting. See [10.4](#).

*Exception No. 1: The requirement that a switch be deterred from turning or shifting may be waived if all four of the following conditions are met:*

- a) *The switch is of a plunger or other type that does not tend to rotate when operated. A toggle switch is considered to be subject to forces that tend to turn the switch during the normal operation of the switch.*
- b) *Means for mounting the switch make it unlikely that operation of the switch will loosen it.*
- c) *The spacings are not reduced below the minimum acceptable values if the switch rotates.*
- d) *Normal operation of the switch is by mechanical means rather than by direct contact by persons.*

*Exception No. 2: A lampholder of a type in which the lamp cannot be replaced, such as a neon pilot or indicator light in which the lamp is sealed in a nonremovable jewel, need not be deterred from turning if rotation cannot reduce spacings below the minimum acceptable values.*

10.4 The means for preventing the turning mentioned in [10.3](#) is to consist of more than friction between surfaces – for example, a properly applied lock washer is acceptable as means to deter turning of a small stem-mounted switch or other device having a single-hole mounting means.

10.5 If a motor shipped detached from a tool is intended to be installed in the field according to the instructions provided with the tool, proper alignment shall be provided for by location and size of the mounting hardware. If a motor is intended to be used on a belt-driven tool, the necessary pulleys for field installation shall be provided with the tool. See [83.1.4](#).

10.6 With reference to the requirement in [10.5](#), adjustment means may be provided to allow for belt tensioning and alignment.

## 11 Protection Against Corrosion

11.1 Iron and steel parts shall be protected against corrosion by enameling, galvanizing, plating, or other equivalent means if the corrosion of such parts would be likely to result in a risk of fire, electric shock, or injury to persons.

*Exception No. 1: A surface of sheet steel or a cast-iron part in an enclosure if the oxidation of the iron or steel due to the exposure of the metal to air and moisture is not likely to be appreciable need not comply with this requirement. The thickness of the metal and the temperature are also factors.*

*Exception No. 2: Bearings, laminations, and minor parts of iron or steel, such as washers, screws, and the like, need not comply with this requirement.*

## **12 Power Supply Connections— Permanently Connected Tools**

### **12.1 General**

12.1.1 A tool intended for permanent connection to the power-supply circuit shall have provision for the connection of a wiring system.

### **12.2 Wiring compartments**

12.2.1 The location of a wiring compartment in which connections to the supply circuit are intended to be made shall be such that these connections can be readily inspected after the tool is installed as intended.

12.2.2 A wiring compartment intended for connection of a wiring system shall be attached to the tool so as to be prevented from turning with respect thereto.

12.2.3 A wiring compartment and any other space intended to enclose wires shall be free of any sharp edge, burr, fin, moving part, or the like, that could damage the conductor insulation.

### **12.3 Wiring terminals and leads**

12.3.1 A field-wiring terminal is considered to be a terminal to which a wire may be connected in the field, unless the wire is provided as part of the tool and a pressure wire connector, a soldered loop, a crimped eyelet, or other means of making the connection is factory-assembled to the wire.

12.3.2 A permanently connected tool shall be provided with field-wiring terminals for the connection of conductors having an ampacity suitable for the tool, or it shall be provided with field-connection leads for such connection.

12.3.3 A field-wiring terminal shall be provided with a pressure wire connector, firmly bolted or held by a screw.

*Exception: A wire-binding screw may be employed at a field-wiring terminal intended to accommodate a 10 AWG (5.3 mm<sup>2</sup>) or smaller conductor if upturned lugs or the equivalent are provided to hold the wire in position.*

12.3.4 A wire-binding screw shall not be smaller than No. 10 (5.3 mm<sup>2</sup>).

*Exception: A No. 8 screw may be used at a field-wiring terminal intended only for the connection of a 14 AWG (2.1 mm<sup>2</sup>) conductor.*

12.3.5 A field-wiring terminal shall be prevented from turning.

12.3.6 A terminal plate tapped for a wire-binding screw shall be of metal not less than 0.05 in (1.27 mm) thick. There shall be two or more full threads in the metal, which may be extruded if necessary to provide the threads.

*Exception: A plate equal to or greater than 0.03 in (0.76 mm) thick may be used if the tapped threads have acceptable mechanical strength.*

12.3.7 Upturned lugs or a cupped washer shall be capable of retaining a conductor corresponding in size to that mentioned in [12.3.2](#) under the head of the screw or washer.

12.3.8 The free length of a field-connection lead inside an outlet box or a wiring compartment shall be 6 in (152 mm) or more.

## 12.4 Grounded power-supply conductor

12.4.1 A permanently connected tool rated 125 V or 125/250 V, 3-wire, or less employing a lampholder of the Edison screw-shell type, a single-pole switch, or a single-pole overcurrent-protective device other than an automatic control without a marked off position shall have one field-wiring terminal or field-connection lead that is identified for the connection of the grounded conductor of the supply circuit. The terminal or lead intended to be grounded shall be electrically connected to screw shells of lampholders and not to a switch or overcurrent-protective device of the single-pole type, other than an automatic control without a marked off position.

*Exception: A double insulated tool complying with the requirements in Sections [89](#) – [93](#) need not comply with this requirement.*

12.4.2 A field-wiring terminal intended for connection of a grounded supply conductor shall:

- a) Be made of or plated with metal substantially white in color and be readily distinguishable from the other terminals; or
- b) Be clearly identified in some other manner, such as on a wiring diagram permanently attached to the tool.

12.4.3 A lead intended for field-connection of a grounded supply conductor shall be finished to show a white or grey color, and shall be readily distinguishable from the other lead or leads.

## 12.5 Equipment-grounding conductor

12.5.1 A field-wiring terminal or field-connection lead for an equipment-grounding conductor shall be provided.

*Exception: A double insulated tool complying with the requirements in Sections [89](#) – [93](#) need not comply with this requirement.*

12.5.2 The surface of a lead intended for field-connection of an equipment-grounding conductor shall be green with or without one or more yellow stripes, and no other lead shall be so identified.

12.5.3 A wire-binding screw intended for the connection of an equipment-grounding conductor shall have a green-colored head that is hexagonal, slotted, or both. A pressure wire connector intended for connection of such a conductor shall be plainly identified, such as by being marked "G," "GR," "GND," "Ground," "Grounding," with the symbol  $\oplus$ , or the like, or by a marking on a wiring diagram provided on the tool. The wire-binding screw or pressure wire connector shall be located so that it is unlikely to be removed during normal servicing of the tool.