



UL 879

STANDARD FOR SAFETY

Electric Sign Components

[ULNORM.COM](https://www.ulnorm.com) : Click to view the full PDF of UL 879 2022

[ULNORM.COM](https://www.ulnorm.com) : Click to view the full PDF of UL 879 2022

UL Standard for Safety for Electric Sign Components, UL 879

Ninth Edition, Dated October 9, 2009

Summary of Topics

This revision of ANSI/UL 879 dated April 22, 2022 includes the following changes in requirements:

- Components for use in LED signs and changing message signs; [Table 1.1](#), [1.3.41.1](#), [Section 2.14.9](#), [4.18.1.1 – 4.18.1.3](#), [Table 4.4.0](#), [4.18.2.1 – 4.18.2.3](#), [4.18.3.1](#), [4.18.4.1](#), [4.18.5.1 – 4.18.5.6](#), [4.18.5.8](#), [4.18.8.1](#), [4.18.10.1](#), [4.18.11.4](#), [Section 4.23](#), [Appendix A](#)***
- Reference to generic RTI in UL 746B; [2.1.4.3](#), [Table 2.5](#), [Table 3.9](#)***
- Editorial revisions; [2.16.2](#), [3.2.2.1.3.2](#), [Appendix B](#)***

Text that has been changed in any manner or impacted by UL's electronic publishing system is marked with a vertical line in the margin.

The new and revised requirements are substantially in accordance with Proposal(s) on this subject dated June 18, 2021 and April 6, 2022.

All rights reserved. No part of this publication may be reproduced, stored in a retrieval system, or transmitted in any form by any means, electronic, mechanical photocopying, recording, or otherwise without prior permission of UL.

UL provides this Standard "as is" without warranty of any kind, either expressed or implied, including but not limited to, the implied warranties of merchantability or fitness for any purpose.

In no event will UL be liable for any special, incidental, consequential, indirect or similar damages, including loss of profits, lost savings, loss of data, or any other damages arising out of the use of or the inability to use this Standard, even if UL or an authorized UL representative has been advised of the possibility of such damage. In no event shall UL's liability for any damage ever exceed the price paid for this Standard, regardless of the form of the claim.

Users of the electronic versions of UL's Standards for Safety agree to defend, indemnify, and hold UL harmless from and against any loss, expense, liability, damage, claim, or judgment (including reasonable attorney's fees) resulting from any error or deviation introduced while purchaser is storing an electronic Standard on the purchaser's computer system.

No Text on This Page

[ULNORM.COM](https://ulnorm.com) : Click to view the full PDF of UL 879 2022

OCTOBER 9, 2009
(Title Page Reprinted: April 22, 2022)



ANSI/UL 879-2022

1

UL 879

Standard for Electric Sign Components

The first through seventh editions were titled Electrode Receptacles for Gas-Tube Signs.

Fifth Edition – August, 1981
Sixth Edition – February, 1993
Seventh Edition – January, 1997
Eighth Edition – June, 2005

Ninth Edition

October 9, 2009

This ANSI/UL Standard for Safety consists of the Ninth Edition including revisions through April 22, 2022.

The most recent designation of ANSI/UL 879 as an American National Standard (ANSI) occurred on April 22, 2022. ANSI approval for a standard does not include the Cover Page, Transmittal Pages, and Title Page.

Comments or proposals for revisions on any part of the Standard may be submitted to UL at any time. Proposals should be submitted via a Proposal Request in UL's On-Line Collaborative Standards Development System (CSDS) at <https://csds.ul.com>.

UL's Standards for Safety are copyrighted by UL. Neither a printed nor electronic copy of a Standard should be altered in any way. All of UL's Standards and all copyrights, ownerships, and rights regarding those Standards shall remain the sole and exclusive property of UL.

NOTE – The user's attention is called to the possibility that compliance with this standard may require use of an invention covered by patent rights.

By publication of this standard, no position is taken with respect to the validity of this claim or of any patent rights in connection there with. The patent holder has, however, filed a statement of willingness to grant a license under these rights on reasonable and nondiscriminatory terms and conditions to applicants desiring to obtain such a license. Details may be obtained from UL.

COPYRIGHT © 2022 UNDERWRITERS LABORATORIES INC.

No Text on This Page

ULNORM.COM : Click to view the full PDF of UL 879 2022

CONTENTS

1	General	5
1.1	Scope	5
1.2	Component identification requirements	6
1.3	Glossary	8
1.4	Components	14
1.5	Undated references	14
1.6	Units of measurement	14
2	Construction	14
2.1	Enclosure	14
2.2	Insulating barrier	23
2.3	Accessibility barrier	24
2.4	Openings and open holes	27
2.5	Sign body	29
2.6	Gaskets and bushings	29
2.7	Corrosion protection	29
2.8	Mechanical joints and fastenings	30
2.9	Sharp edges	31
2.10	Supply connections	31
2.11	Equipment grounding and bonding	36
2.12	Current-carrying parts	40
2.13	Insulating materials	50
2.14	Electrical components	51
2.15	Spacings	55
2.16	Markings	59
3	Tests – General	60
3.1	General	60
3.2	Polymeric material evaluation	61
3.3	Inorganic, nonmetallic tests	84
3.4	Product tests	84
4	Specific Components Only for Use in an End Product	108
4.1	General	108
4.2	Electrode receptacles, other than the through wall housing type	116
4.3	Feed type over 1000 V lampholders	120
4.4	Interconnecting over 1000 V lampholders	123
4.5	Electrode receptacle enclosure	126
4.6	Polymeric neon electrode enclosures	128
4.7	Glass cup receptacles	131
4.8	Glass tubing conduit assembly	134
4.9	GTO cable sleeving	135
4.10	GTO cable splice enclosure	137
4.11	Sign body, awning and face material-not enclosure rated	140
4.12	Enclosure sign face materials	141
4.13	Sign face tensioning systems	142
4.14	Structural materials	143
4.15	Electrode receptacle insulator	144
4.16	Trim cap	145
4.17	Dimmers, flashers, controllers and animators	146
4.18	LED components	148
4.19	Electroluminescent displays	153
4.20	Switch enclosures	155
4.21	Sign rotating equipment	156
4.22	Clock mechanisms	158
4.23	LCD displays	161

5	Sign Components for Field and Factory Installation.....	161
5.1	General	161
5.2	Markings.....	162
5.3	Installation instructions.....	162
5.4	Through wall electrode receptacles	162
5.5	Receptacle caps.....	167
5.6	Electrode receptacle grounding means	169
5.7	Cold cathode and over 1000-V lampholder systems	169
5.8	Electrode receptacle enclosure.....	171
5.9	Neon electrode splice and GTO cable polymeric enclosure systems.....	172
5.10	Glass cup neon electrode receptacle and GTO cable splice enclosure systems	175
5.11	GTO cable splice enclosure	176
5.12	Neon electrode enclosure and GTO cable with integral sleeving enclosure system	177
5.13	GTO cable assemblies	179
5.14	Neon transformer enclosures.....	187
5.15	Neon tubing support, cable support and cable bushing	187
5.16	Sign dimmers, flashers, controllers and animating equipment	191
5.17	Lubricant.....	192
6	Manufacturing and Production Tests	195
6.1	Grounding continuity test.....	195
6.2	Dielectric voltage-withstand test.....	195

APPENDIX A

Standards for Components	197
--------------------------------	-----

APPENDIX B

ULNORM.COM : Click to view the full PDF of UL 879 2022

1 General

1.1 Scope

1.1.1 These requirements cover components for use in signs and outline lighting systems intended for installation in accordance with the National Electrical Code, NFPA 70. Components covered by this standard include the types specified in [1.1.2](#), including electromechanical components that convey a message or outline the structural features of a building by electronically directing or rechanneling available light from other sources and involving all forms of illumination such as:

- a) Fluorescent lighting,
- b) High intensity discharge (HID) lighting,
- c) Neon lighting,
- d) Cold cathode lighting,
- e) Light emitting diodes (LED), and
- f) Electroluminescent lighting.

1.1.2 Examples of components intended to be covered by this standard include:

- a) Materials used in signs and outline lighting such as structural panels, sign face materials, switch enclosures, sign frames, electrical enclosures, accessibility barriers, trim caps, water shields, coatings and lubricants, components related to material installation and the like.
- b) Electrical components relating to illumination circuits operating at 1000 V and above such as electrode receptacles, lampholders, neon electrode enclosures, GTO sleeving, integrally sleeved GTO cable, GTO cable splice enclosures and insulating devices.
- c) Electromechanical and electronic equipment for use in signs such as LED units, LED power sources, sign flashers, animating equipment, scrolling units, and sign rotating equipment.

1.1.3 This standard does not cover components covered by another standard, unless there are additional considerations that need to be addressed when the component is for use in signs and outline lighting.

1.1.4 These requirements do not cover:

- a) Christmas tree and other decorative lighting devices
- b) Exit lighting and luminaires and low level path marking and lighting systems
- c) Fluorescent ballasts
- d) Fluorescent lampholders
- e) Incandescent luminaires
- f) GTO cable
- g) High intensity discharge ballasts
- h) HID lighting luminaires
- i) Incandescent lampholders

- j) Incandescent lighting
- k) Luminaires of any kind
- l) Low voltage landscape lighting systems
- m) Low voltage lighting fixtures for use in recreational vehicles
- n) Low voltage marine lighting
- o) Marine navigational lights
- p) Marine type fixtures
- q) Neon transformers and power supplies
- r) Portable electric displays
- s) Portable handlamps
- t) Portable lamps and cabinet lamps
- u) Portable luminaires
- v) Portable sun/heat lamps
- w) Stage and studio luminaires
- x) Self-ballasted fluorescent lamps
- y) Temporary lighting strings
- z) Track lighting fixtures

1.2 Component identification requirements

1.2.1 All components shall be evaluated for factory installation only as specified in [1.2.2](#) and [1.2.3](#) or evaluated for factory and field installation as specified in [1.2.4](#) and [1.2.5](#).

1.2.2 A factory installed component is intended for use only under limited conditions, such as temperatures not exceeding specified limits, and shall be used only under those specific conditions for which they have been investigated. Components currently identified as intended for factory installation only are identified in [Table 1.1](#).

Table 1.1
Factory installed sign components

Electrode receptacles other than through wall housing type
Feed type lampholders over 1000 V – without conduit connection means
Interconnecting lampholders over 1000 V
Metallic electrode receptacle enclosure
Neon electrode enclosure
Glass cup receptacles
Conduit plug assembly
GTO cable sleeving
GTO cable with integral sleeving
GTO cable splice enclosure
Neon tube support
Sign face material – not enclosure rated
Enclosure sign face materials
Sign face tensioning systems
Structural materials
Dimmers, flashers, controllers and animators
LED display units
Electroluminescent displays
Switch enclosures
Sign rotating equipment
Clock mechanisms
Lubricant
LCD displays

1.2.3 Components for factory installation only as identified in [Table 1.1](#) shall comply with the requirements in Sections [2](#) – [4](#).

1.2.4 A field and factory installed component shall be intended and suitable for use in field assembled skeletal neon signs and outline lighting installations in accordance with the National Electrical Code, NFPA 70. These components shall be of a construction that does not place unique limits on the use of the components such that they cannot be installed in accordance with the requirements of NFPA 70. Components currently identified as intended for use in field assembled skeletal neon signs and outline lighting are identified in [Table 1.2](#).

1.2.5 Components for field and factory installation, as identified in [Table 1.2](#), shall comply with the requirements in Sections [2](#) – [5](#) including maximum voltage rating, type of location, minimum temperature rating, and all other applicable requirements.

Table 1.2
Field installed and factory installed components

Field and factory installed components
Through wall electrode receptacles
Through wall housing receptacle grounding means
Lampholder systems over 1000 V
Electrode receptacle enclosure
Neon electrode splice and GTO cable polymeric enclosure systems (boots and sleeves)
Glass cup neon electrode receptacle and GTO cable splice enclosure systems
GTO cable splice enclosure
GTO cable with integral sleeving
GTO cable assemblies
Neon transformer enclosures
Neon tubing supports, cable supports and cable bushings
Sign dimmers, flashers, controllers and animating equipment

1.3 Glossary

1.3.1 For the purpose of this standard, the following definitions apply. Definitions provided might not be terms used in the standard, but are provided to establish a basis of understanding terms used by the sign industry, component manufacturers and others.

1.3.2 ACCESSIBILITY BARRIER – Material provided to limit access to the following. If all or part of the barrier also serves as an enclosure, see Enclosure, [1.3.22](#).

- a) Uninsulated live parts,
- b) Dead metal parts that are at a risk of being energized and are not grounded,
- c) Live parts insulated with materials not intended to be subject to user contact, or
- d) Moving parts that present a risk of injury.

1.3.3 ACCESSIBLE PART – See definitions for Part, [1.3.54](#).

1.3.4 ADHESIVE – Bonding material (i.e. epoxy, paste, cement) placed between parts to be fastened together that adheres to each part, and remains the securement medium between the parts.

1.3.5 BARRIER – See Accessibility Barrier [1.3.2](#), Insulating Barrier [1.3.37](#), Isolating Barrier [1.3.41](#), Thermal Barrier [1.3.68](#), and Water shield [1.3.73](#).

1.3.6 BLOCK-OUT PAINT – Used to coat a neon tube to block the emission of light from a neon tube. Generally applied over the electrode, it can also be applied at various points along the tube.

1.3.7 BONDING – Permanent joining of metallic parts to form an electrical conductivity path that provides electrical continuity between dead metal parts and the capacity to conduct any fault current which may occur.

1.3.8 BONDING CONDUCTOR – Electrically connects non-current carrying metal parts such as enclosure parts, frame parts and dead metal parts of electrical components to each other and the equipment grounding means.

- 1.3.9 ENCLOSURE, NEON – See the definition for neon electrode enclosure, [1.3.45](#).
- 1.3.10 CLASS 2 CIRCUIT – Wiring, conductors and components connected only to a Class 2 supply source. See Class 2 Supply Source, [1.3.11](#).
- 1.3.11 CLASS 2 SUPPLY SOURCE – Electrical source such as a transformer, power supply, or battery having an open-circuit voltage that is less than 30 Vrms. (42.4 V peak) or 60 V DC and having limited energy available in the circuit under load conditions, including short-circuit and extremely low resistance.
- 1.3.11.1 INHERENTLY LIMITED SUPPLY SOURCE – Transformer, power supply or battery having no discrete protective device that is relied upon to limit the output energy available from the supply. A power supply or battery with internal current and energy limiting circuitry shown to be reliable is eligible to be identified as inherently limited. Transformers, power supplies and batteries may be provided with protective devices as long as they are not relied upon to limit the output energy.
- 1.3.11.2 INHERENTLY LIMITED SUPPLY SOURCE – Transformer, power supply or battery having a discrete protective device that automatically interrupts the output when the current and energy output reaches a prescribed limit.
- 1.3.12 COLD-CATHODE TUBING – Neon tubing that is larger than 15 mm (0.6 inch) in diameter and that operates between 120 and 240 mA. Cold-cathode tubing is similar to other forms of neon tubing that do not require heating above ambient temperatures to initiate ionization resulting in the tube producing light.
- 1.3.13 COLLAR FERRULE – That portion of a neon tube electrode receptacle of a threaded sheet metal form that tightens over the receptacle for purposes of means of mounting the receptacle in place.
- 1.3.14 CURRENT CARRYING LIVE PART – See Part, [1.3.54](#).
- 1.3.15 DOUBLE BACK – A 180 degree return bend made in neon tubing near an electrode.
- 1.3.16 ELECTRIC DISCHARGE – Method of illumination whereby current is passed through a gas medium. This includes neon, cold cathode, fluorescent, and high-intensity-discharge types of illumination
- 1.3.17 ELECTRODE – Cold cathode or neon tube assembly consisting of metallic conducting elements. The electrode is joined to both ends of a cold cathode and neon tube.
- 1.3.18 ELECTRODE RECEPTACLE – A contact device intended to accept electrodes of neon tubing. An individual receptacle may or may not be provided with an integral outer housing of metal or other material.
- 1.3.19 ELECTRODE RECEPTACLE CAP – Material formed to cover the mouth of an electrode receptacle while permitting a neon tube to enter the mouth. The combination of neon tube and electrode receptacle cap function as a water shield to prevent the entrance of water into the mouth of the electrode receptacle.
- 1.3.20 ELECTRODE SPLICE ENCLOSURE – Component specifically intended to enclose a splice between a GTO Cable conductor and the leads of a neon tube electrode.
- 1.3.21 ELEVATION POSTS – See tube support, [1.3.70](#).
- 1.3.22 ENCLOSURE – Material provided to enclose electrical parts and components to contain a potential risk of fire. See Accessibility Barrier when an enclosure also serves as an accessibility barrier [1.3.2](#).

- 1.3.23 ENCLOSURE RATED SIGN FACE – Sign face that is designated as being suitable to enclose current carrying live parts.
- 1.3.24 EXPOSED LIVE PART – See part, [1.3.54](#).
- 1.3.25 EXTRA LOW VOLTAGE CIRCUIT (ELV) – Circuit with limited voltage and energy that reduces the risk of fire and shock in accordance with the requirements in the Standard for Information Technology Equipment Safety – Part 1: General Requirements, UL 60950-1.
- 1.3.26 FACTORY INSTALLED SIGN COMPONENT – Component intended for use in signs and outline lighting that is installed at the sign manufacturing location. The sign or outline lighting is provided with an enclosure or sign body for the attachment/assembly of the component. Factory assembled signs and outline lighting are determined to comply with the end product requirements at a manufacturing facility.
- 1.3.27 FIELD AND FACTORY INSTALLED SIGN COMPONENT – Component intended for use in 1) skeletal neon signs and outline lighting installations and 2) factory assembled signs and outline lighting.
- 1.3.28 FIELD WIRING TERMINAL – Terminal connection expected to be made in the field rather than as part of a manufacturing process.
- 1.3.29 FLEXIBLE SIGN FACE – Sign face that is not rigid enough to support itself.
- 1.3.30 GROUNDED CONDUCTOR – Supply circuit conductor intentionally connected to ground at the building supply source. Also known as "common" or "neutral".
- 1.3.31 EQUIPMENT GROUNDING CONDUCTOR – Conductor provided to bond dead metal of a product to earth ground.
- 1.3.32 GTO CABLE – Gas tube oil ignition cable. Rated 5 kV, 10 kV, or 15 kV for use between the secondary or output of a neon supply and neon tubing and between segments of neon tubing.
- 1.3.33 GTO CABLE SPLICE ENCLOSURE – Containment device intended to enclose the splice of two lengths of GTO cable that complies with the enclosure requirements.
- 1.3.34 GTO SLEEVING – A component specifically identified for use over GTO cable.
- 1.3.35 GUARD – Part provided primarily for the purpose of limiting user access to components with a potential risk of injury to persons (for example, high-temperature or moving parts).
- 1.3.36 HAZARDOUS ENERGY LEVEL – Stored energy level of 20 J or more, or an available continuous power level of 240 VA or more, at a potential of 2 V or more.
- 1.3.37 INSULATING BARRIER – Barrier provided in place of a required electrical spacing and is in direct contact with live parts.
- 1.3.38 INSULATED LIVE PART – See definitions for Part, [1.3.54](#).
- 1.3.39 INTEGRALLY SLEEVED GTO CABLE – GTO cable that conforms to additional construction requirements specified in this standard.
- 1.3.40 ISOLATED LIVE PART – See definitions for Part, [1.3.54](#).

1.3.41 ISOLATING BARRIER – Barrier not in direct contact with live parts which is provided to maintain separation between circuits of opposite polarity or to reduce a required electrical spacing.

1.3.41.1 LED DISPLAY UNIT – An arrangement of discrete LEDs, LED array(s) or LED panel(s) assembled to display data in the form of images in changing message signs. LED display units are not intended to provide general illumination.

1.3.42 LIMITED POWER SOURCE (LPS) – Power supplies identified as “LPS” or where the output is considered limited power, are considered equivalent to power supplies with Class 2 outputs.

1.3.43 LOCATION OF USE DESIGNATION

1.3.43.1 DRY – Designation for a component that has been evaluated for use in an environment where the component is not normally subject to dampness or wetness. Examples include inside an indoor shopping mall, inside a retail store, and other similar places.

1.3.43.2 DAMP – Designation for a component that has been evaluated for use in exterior locations where protected overhead from rain and snow, or interior locations where subject to moderate degrees of moisture, primarily by humidity and condensation. Protection overhead is generally considered to be within an area formed by an imaginary line drawn from the outer edge of the eave, overhang or sign body inward at a 45° angle from vertical. Additionally, the interior of a sign body provided with a sign face and installed in an outdoor exposed location is a damp location. Examples include protected areas such as under a canopy and under a roofed porch.

1.3.43.3 WET – Designation of a component that has been evaluated for use in a location that is subject to precipitation, direct spray or splashing of water or other liquids. Examples include locations used for outdoor channel letters and outline lighting.

1.3.44 LUMINOUS TUBE – See the definition for Neon Tubing [1.3.46](#).

1.3.45 NEON ELECTRODE ENCLOSURE – Component designed to fit over the end of neon electrode to enclose the splice between the lead of the electrode and GTO cable lead.

1.3.45.1 NEON ENCLOSURE SYSTEM – A system of parts intended to enclose GTO wire, neon tubing electrode, and its connection in a wet location.

1.3.46 NEON TUBING – An industry term for electric-discharge lamps or tubing used in signs and outline lighting, including cold-cathode lamps, regulated by Article 600 of the National Electric Code, NFPA 70.

1.3.47 NEON TUBING CLEAR COAT – Clear coating of a vinyl type material applied over the length of a neon tube to protect other coatings and mechanically strengthen a neon tube.

1.3.48 NEON TUBING LUBRICANT – Compound applied to the end of a neon tube for the purpose of making it easier to slide a close fitting neon electrode enclosure over the end of an electrode.

1.3.49 NEON TUBING TINT – Coating applied to neon tubes to block the emission of one or more light frequencies to change the overall appearance of the light from a neon tube.

1.3.50 OPEN HOLE – Aperture in an accessibility barrier or enclosure that is not covered or filled by another part. Typically, open holes are provided for ventilation, mounting means, and supply connections.

1.3.51 OPENING – Aperture in an enclosure that is covered or filled by a plug or knockout and that has the potential of becoming an open hole. Typically, openings relate to supply connections, commonly referred to as a knockout, and accessibility for inspection of splices.

1.3.52 ORDINARY TOOLS – For the purposes of these requirements, ordinary tools are defined as flat blade and Phillips head screwdrivers, nut drivers, and pliers.

1.3.53 OUTDOORS – Identifies a location that could be either outdoor protected (now defined as a damp location), or outdoor exposed (now defined as a wet location). See definitions for Location of Use Designation, [1.3.43](#), for the definition of current terminology.

1.3.54 PART

1.3.54.1 ACCESSIBLE – An electrical or moving part that is accessible to a user during user servicing.

1.3.54.2 CURRENT CARRYING LIVE – An electrical part such as a wire or lampholder, that carries electrical and qualifies to be considered an insulated live part.

1.3.54.3 EXPOSED LIVE – Electrical or moving part that is accessible to a user during normal use.

1.3.54.4 ISOLATED LIVE – Electrical part that is isolated from ground reference as a result of an electrical component such as a ferromagnetic transformer.

1.3.54.5 INSULATED LIVE – Electrical part that is energized and surrounded by insulation that is suitable for the voltage involved.

1.3.55 PERFORMANCE LEVEL CATEGORY (PLC) VALUE – Integer that defines a range of test values for a given electrical/mechanical property test for polymeric (plastic) materials.

1.3.56 PRESSURE WIRE TERMINAL – Wiring terminal that secures and makes electrical connection for one or more wires. This is accomplished by means of a tightening device that presses and captures a straight segment of the conductor(s) between conductive surfaces.

1.3.57 RIGID SIGN FACE – Material formed as a sign face that is rigid enough to be self supporting when secured in place and does not require a tensioning system.

1.3.58 SAFETY EXTRA-LOW VOLTAGE (SELV) CIRCUIT – Secondary circuit with limited voltage and energy that reduces the risk of fire and shock in accordance with the requirements in the Standard for Information Technology Equipment Safety – Part 1: General Requirements, UL 60950-1.

1.3.59 SIGN BODY – Portion of a sign that provides protection from the weather but is not an electrical enclosure.

1.3.60 SIGN FACE – Part of the overall exterior of a sign intended to convey a message or display an art form and transmits or reflects and internal light source. A sign face may function as a water shield and/or accessibility barrier. A sign face may also be enclosure rated.

1.3.61 SIGN FACE TENSIONING – Clamps, fasteners, and the like provided to secure a flexible sign face material across the sign and maintain tension on the sign face material.

1.3.62 SIGN DESIGNATION

1.3.62.1 FIXED – Intended to be permanently connected to an electrical source of supply.

1.3.62.2 PORTABLE – Meets all of the following:

- a) When provided with mounting means, is removable from its intended mounting without the use of tools,
- b) weighs 22.7 kg (50 lb) or less,
- c) Product of its longest dimension times its weight does not exceed 575 kg-mm (1500 lb-in), and
- d) Is connected to an electrical source of supply by a power-supply cord.

1.3.62.3 STATIONARY – Meets all of the following:

- a) Intended to be fastened in place or located in a dedicated space (not portable);
- b) Removable from its intended mounting with the use of no more than ordinary tools; and
- c) Connected to an electrical source of supply by a power supply cord.

1.3.63 SKELETAL NEON SIGNS AND OUTLINE LIGHTING – Neon tubing is itself the sign or outline lighting and the body of the sign or outline lighting is the building or structure onto which the neon tubing is directly installed.

1.3.64 SLEEVING – Covering, or an insulating or protective sheath, or both, that is intended to cover an electrical part, such as a conductor, a connection, or a splice.

1.3.65 SOLVENT – Material that acts as a catalyst on parts to be fastened that causes fusing of the parts to each other, after which the material evaporates and no longer exists as a fastening medium.

1.3.66 SPLICE – Any point where one wire is connected to another wire. A wire terminating at a pressure wiring terminal or wire binding screw is not considered to be a splice.

1.3.67 STRAIN RELIEF DEVICE – Knot, bushing, or equivalent intended to prevent strain from being transmitted through that portion of a wire or cord outside a product to the termination point of the wire or cord inside the product.

1.3.68 THERMAL BARRIER – Provided to reduce the transfer of thermal energy from one component to another where maximum temperature considerations are required.

1.3.69 THROUGH WALL ELECTRODE RECEPTACLE – Neon receptacle with integral metal housing, intended for conduit connection of high voltage supply. These may also be referred to as metal enclosed electrode receptacles.

1.3.70 TUBE SUPPORT – Elevation post or standoff used to secure neon tubes in place.

1.3.71 UNGROUNDED CONDUCTOR – Supply conductor that is not connected to the ground system or grounding electrode. Commonly called the "live" or "hot" conductor.

1.3.72 USER SERVICEABLE PART – Component or part intended to be replaced or adjusted by the user of a sign.

1.3.73 WATER SHIELD – Material relied upon to reduce or prevent the entrance of water into a sign or onto current-carrying parts within a sign.

1.3.74 WEATHERPROOF – See wet location [1.3.43.3](#).

1.3.75 WIRE BINDING SCREW – Screw where the threaded portion acts as a post around which a single wire is to be wrapped.

1.3.76 WIRE – Consists of a metallic conductor provided with insulation along its length, the combination of which define the maximum voltage rating and current carrying abilities.

1.4 Components

1.4.1 Except as indicated in [1.4.2](#), a component of a product covered by this Standard shall comply with the requirements for that component. See Appendix A for a list of Standards covering components generally used in the products covered by this Standard.

1.4.2 A component is not required to comply with a specific requirement that:

- a) Involves a feature or characteristics not needed in the application of the component in the product covered by this Standard; or
- b) Is superseded by a requirement in this Standard.

1.4.3 A component shall be used in accordance with its rating for the intended use.

1.4.4 Specific components are accepted as being incomplete in construction features, or restricted in performance capabilities. Such components are intended for use only under limited conditions, such as temperatures not exceeding specified limits, and shall be used only under those specific conditions to which they have been investigated.

1.5 Undated references

1.5.1 Any undated reference to a code or standard appearing in the requirements of this standard shall be interpreted as referring to the latest edition of that code or standard.

1.6 Units of measurement

1.6.1 Values stated without parentheses are the requirement. Values in parentheses are explanatory or approximate information. See Appendix B for metric conversion multipliers.

1.6.2 Unless otherwise stated, all voltage and current values mentioned in this Standard are root-mean-square (rms).

2 Construction

2.1 Enclosure

2.1.1 General

2.1.1.1 Except as specified in [2.1.1.2](#), all insulated and uninsulated current-carrying parts shall be enclosed in metal, glass or polymeric material in accordance with the requirements in [2.1.2](#) through [2.1.4](#). Compliance is permitted to be determined in conjunction with other components as specified in [2.1.1.4](#).

2.1.1.2 Insulated and uninsulated current-carrying parts identified for use when connected to a voltage and power limited circuit are not required to be enclosed. A supply source is considered power limited when it has voltage, current and energy output limitations in accordance with [2.12.6.1](#).

2.1.1.3 All neon tubing and lamps are to be installed as intended when determining compliance with the enclosure requirements.

2.1.1.4 A component intended for installation in conjunction with another component found to comply with this standard, is permitted to rely on the other component to comply with the enclosure requirements.

2.1.2 Metal enclosures

2.1.2.1 A metal enclosure shall comply with the requirements in [2.1.2.2](#) through [2.1.2.9](#) and [Table 2.1](#), [Table 2.2](#) or [Table 2.3](#).

Table 2.1
Thickness of cast-metal enclosures

Material/location	Minimum thickness of cast metal			
	Unreinforced		Reinforced ¹⁾	
	mm	(in)	mm	(in)
Cast metal	3.2	0.126	2.4	0.094
Cast malleable iron	2.4	0.094	1.6	0.063
At a threaded conduit hole	2.4	0.094	1.6	0.063
At an unthreaded conduit hole	2.0	0.079	1.2	0.047

Notes:

1. Reinforced – When the material is provided with integrally cast angles, channels, ribs, flanges or ridges.
2. Threads and Breakouts – Areas around threads, breakouts, or similar features are permitted to be thinner, providing the strength of structure is not affected, but in case thinner than permitted for the same length of sheet metal.

Table 2.2
Minimum thickness of uncoated and zinc coated steel

Specific construction		Uncoated steel				Zinc coated or galvanized steel			
		Unreinforced		Reinforced		Unreinforced		Reinforced	
		mm	(in)	mm	(in)	mm	(in)	mm	(in)
At opening for conduit connection		0.66	0.026	0.66	0.026	0.74	0.029	0.74	0.029
Length not more than 38 cm (15 in)	No electrical component support	0.41	0.016	0.33	0.013	0.48	0.019	0.41	0.016
	Electrical component support	0.41	0.016	0.41	0.016	0.48	0.019	0.48	0.019
Length more than 38 cm (15 in) and less than 66 cm (26 in)	No electrical component support	0.41	0.016	0.33	0.013	0.48	0.019	0.48	0.019
	Electrical component support	0.51	0.020	0.41	0.016	0.58	0.023	0.48	0.019
Length 66 cm (26 in) and less than 122 cm (48 in)	No electrical component support	0.51	0.020	0.41	0.016	0.58	0.023	0.48	0.019

Table 2.2 Continued on Next Page

Table 2.2 Continued

Specific construction		Uncoated steel				Zinc coated or galvanized steel			
		Unreinforced		Reinforced		Unreinforced		Reinforced	
		mm	(in)	mm	(in)	mm	(in)	mm	(in)
	Electrical component support	0.66	0.026	0.51	0.020	0.74	0.029	0.58	0.023
Length 122 cm (48 in) or more and less than 152.4 cm (60 in)	No electrical component support	0.81	0.032	0.66	0.026	0.84	0.035	0.74	0.029
	Electrical component support	1.07	0.042	0.81	0.032	1.07	0.042	0.81	0.032
Length 152.4 cm (60 in) or more and less than 185.4 cm (73 in)	No electrical component support	1.07	0.042	0.81	0.032	1.07	0.042	0.81	0.032
	Electrical component support	1.35	0.053	1.07	0.042	1.42	0.056	1.14	0.045
Length 185.4 cm (73 in) and more	With or without electrical component support	1.52	0.060	1.35	0.053	1.6	0.063	1.42	0.056

Notes:

- Length – the longest straight line that can be drawn on any unsupported section of an enclosure. The longest straight line is measured in any direction regardless of the shape of the enclosure section in any direction. The longest straight line for an enclosure section that is frame supported in accordance with [2.1.2.8](#) and [2.1.2.9](#), is measured in any direction on the enclosure panel between the frame supporting members.
- Length and frame supported – A section of an enclosure secured to framing members not integral to the enclosure panel in accordance with [2.1.2.8](#) and [2.1.2.9](#).
- Unreinforced – A section of an enclosure as described in [2.1.2.5](#) or that does not comply with the requirements in [2.1.2.3](#) and [2.1.2.4](#) for being a reinforced enclosure section.
- Reinforced – A section of an enclosure that is provided with curves, ribs, breaks or flanged surfaces in accordance with [2.1.2.3](#) and [2.1.2.4](#).
- No electrical component support – the minimum thickness required when no electrical components are secured to and supported by the enclosure surface.

Table 2.3
Minimum thickness of aluminum, copper or brass enclosures

Specific construction		Copper, brass, aluminum sheet and extruded aluminum			
		Unreinforced		Reinforced	
		mm	(in)	mm	(in)
At opening for conduit connection		0.81	0.032	0.81	0.032
Length not more than 38 cm (15 in)	No electrical component support	0.51	0.020	0.41	0.016
	Electrical component support	0.51	0.020	0.51	0.020
Length more than 38 cm (15 in) and less than 66 cm (26 in)	No electrical component support	0.51	0.020	0.41	0.016
	Electrical component support	0.64	0.025	0.51	0.020
Length 66 cm (26 in) and less than 122 cm (48 in)	No electrical component support	0.56	0.022	0.43	0.017
	Electrical component support	0.71	0.028	0.56	0.022

Table 2.3 Continued on Next Page

Table 2.3 Continued

Specific construction		Copper, brass, aluminum sheet and extruded aluminum			
		Unreinforced		Reinforced	
		mm	(in)	mm	(in)
Length 122 cm (48 in) and less than 152 cm (60 in)	No electrical component support	0.91	0.036	0.71	0.028
	Electrical component support	1.47	0.045	0.91	0.036
Length 152 cm (48 in) and less than 185 cm (73 in)	No electrical component support	1.47	0.045	0.91	0.036
	Electrical component support	1.91	0.075	1.47	0.045
Length 185 cm (73 in) or more	With or without electrical component support	2.41	0.095	1.91	0.075

Notes:

- Length – the longest straight line that can be drawn on any unsupported section of an enclosure. The longest straight line is measured in any direction regardless of the shape of the enclosure section in any direction. The longest straight line for an enclosure section that is frame supported in accordance with [2.1.2.8](#) and [2.1.2.9](#), is measured in any direction on the enclosure panel between the frame supporting members.
- Length and frame supported – A section of an enclosure secured to framing members not integral to the enclosure panel in accordance with [2.1.2.8](#) and [2.1.2.9](#).
- Unreinforced – A section of an enclosure as described in [2.1.2.5](#) or that does not comply with the requirements in [2.1.2.3](#) and [2.1.2.4](#) for being a reinforced enclosure section.
- Reinforced – A section of an enclosure that is provided with curves, ribs, breaks or flanged surfaces in accordance with [2.1.2.3](#) and [2.1.2.4](#).
- No electrical component support – the minimum thickness required when no electrical components are secured to and supported by the enclosure surface.

2.1.2.2 The values for minimum metal thickness in [Table 2.1](#), [Table 2.2](#) and [Table 2.3](#) apply to measurements made before the application of paints, varnishes and organic coatings. The values for the minimum metal thickness also apply to measurements made, for other than zinc coated or galvanized steel, before metallic coatings have been applied.

2.1.2.3 A reinforced construction as indicated in [Table 2.1](#), [Table 2.2](#) and [Table 2.3](#), is an enclosure material provided with integral angles, channels, breaks, ribs, flanges or ridges, that provides a mechanical strength across the span of the material that is equivalent to unreinforced material of the thickness required for the same length.

2.1.2.4 For steel, copper, aluminum, brass or extruded aluminum to be considered as reinforced as specified in [Table 2.2](#) and [Table 2.3](#), the material shall be provided with one of the following reinforcement features. The reinforcement feature shall divide the enclosure into sections such that the longest dimension of all of the resulting sections is one third or less than the longest dimension of the undivided enclosure:

- Flanges, angles or breaks that are 45° to 120° to the plane of the panel,
- Ribs and ridges that are at least 3.2 mm (0.126 in) high from the plane of the panel with an internal angle of 45° to 120°,
- Curves running across the shortest dimension, or
- Channels having two 90° angles or breaks running in any direction.

2.1.2.5 The following constructions are not considered to be reinforced:

- A single sheet with a formed edge flange around its perimeter,

- b) A single sheet that is ribbed not meeting the angle criteria in [2.1.2.4](#),
- c) A single sheet that is corrugated with the curves running parallel to the long dimension, and
- d) A single sheet of sheet metal with reinforcement features, but is secured to a peripheral frame by a means that would allow the material to flex at its center. For example, securement by physical fit into a channel.

2.1.2.6 For a cast metal to be considered as reinforced as specified in [Table 2.1](#), the material must be provided with integrally cast angles, channels, ribs, flanges or ridges.

2.1.2.7 The length dimensions specified in [Table 2.1](#), [Table 2.2](#) and [Table 2.3](#) are measured as the longest straight line that can be drawn across any unsupported section of the material. The longest straight line for an enclosure section is measured in any direction regardless of the shape. The longest straight line for an enclosure section that has a supporting frame in accordance with [2.1.2.8](#) and [2.1.2.9](#), is measured in any direction on the enclosure panel between the supporting frame members.

2.1.2.8 A supporting frame is a structure of angle, channel or a rigid folded length of sheet metal that is not an integral part of the enclosure panel and complies with [2.1.2.9](#). The supporting frame must be rigidly attached to the enclosure material at regular intervals and to other materials to which the enclosure material is secured, and have essentially the same outside dimensions as the enclosure surface.

2.1.2.9 A supporting frame shall consist of:

- a) Angle iron or aluminum having a cross sectional dimension of at least 13 by 13 mm (0.5 by 0.5 in) with a material thickness of 8.1 mm (0.266 in);
- b) Flat metal bars which are minimum 9.5-mm (0.375-in) wide and 3.2-mm (0.125-in) thick; or
- c) An internal metal structure such as a chassis, that is rigidly secured together to form a 3 dimensional structure onto which the enclosure material is secured at regular intervals.

2.1.3 Non-metallic inorganic enclosure

2.1.3.1 A non-metallic inorganic enclosure material, such as glass and ceramic, shall be minimum 2.5-mm (0.1-in) thick.

2.1.3.2 A non-metallic inorganic material that encloses live parts shall also comply with the requirements for an insulating barrier as specified in [2.2.1](#).

2.1.3.3 A non-metallic inorganic enclosure material shall comply with the Impact Test in [3.3.1](#).

2.1.3.4 A non-metallic inorganic enclosure material relied upon to house a heat producing component and intended for use in a damp and wet locations shall comply with the Environmental Conditioning Test as specified in [3.3.2](#).

2.1.3.5 A non-metallic inorganic enclosure material intended for use in wet locations shall comply with the Thermal Shock Test as specified in [3.3.3](#).

2.1.4 Polymeric enclosures other than neon electrode enclosures or GTO sleeving

2.1.4.1 An enclosure of polymeric material shall comply with the requirements specified in [2.1.4.2](#) – [2.1.4.7](#). Polymeric material includes thermoplastic and thermosetting materials and composite type materials bonded together by organic compounds. Thermosetting material is a polymeric material such as phenolic and epoxy that are cast rather than molded.

2.1.4.2 An enclosure material shall comply with the requirements in [Table 2.4](#) and where applicable, additional requirements in Sections [4](#) and [5](#) specific component.

ULNORM.COM : Click to view the full PDF of UL 879 2022

**Table 2.4
Polymeric enclosure material requirements**

Installation Type				Location Designation			Type of Sign Illumination				Flammability		Min. RTI	UV
*P	Portable			Dry	Damp	Wet	*I	*F	HID	LED	Any V Rating	5 VA Rating		
	Table Top	Wall only	Wall and Pendant or Pendant Only											
X				X			X					X	Measured Temperature	
X				X				X				X	Measured Temperature	X
X				X					X			X	Measured Temperature	X
X				X						X		X	Measured Temperature	
X					X		X					X	Measured Temperature +15°C (27°F)	
X					X			X				X	Measured Temperature +15°C (27°F)	X
X					X				X			X	Measured Temperature +15°C (27°F)	X
X					X					X		X	Measured Temperature +15°C (27°F)	
X						X	X					X	Measured Temperature +15°C (27°F)	X
X						X		X				X	Measured Temperature +15°C (27°F)	X
X						X			X			X	Measured Temperature +15°C (27°F)	X

Table 2.4 Continued on Next Page

Table 2.4 Continued

Installation Type				Location Designation			Type of Sign Illumination				Flammability		Min. RTI	UV
*P	Portable			Dry	Damp	Wet	*I	*F	HID	LED	Any V Rating	5 VA Rating		
	Table Top	Wall only	Wall and Pendant or Pendant Only											
X						X				X		X	Measured Temperature +15°C (27°F)	X
	X			X			X				X		Measured Temperature	
	X			X				X			X		Measured Temperature	X
	X			X						X	X		Measured Temperature	
		X			X		X				X		Measured Temperature	
		X			X			X			X		Measured Temperature	X
		X			X					X	X		Measured Temperature	
			X	X	X	X	X	X	X	X	X		Measured Temperature +15°C (27°F)	X

* P – Permanent, I – Incandescent, F – Fluorescent and Neon

Notes:

1. An "X" provided in a column under Installation and Illumination Type in the row of a component, identifies the use of a component.
2. A component designated for a particular type of sign installation is considered a limited component provided with appropriate information identifying the conditions of its limited use. A component that carries no installation type limitation instruction is to comply with the more stringent temperature and flammability requirements.
3. A component designated for use in a permanently installed sign and is designated for use in a damp location is acceptable for installation in a wet location sign subject which is also considered subject to increased ambient conditions from external infrared radiation.
4. A component designated for use in a permanently installed sign and is designated for use in a wet location is considered to include being installed where subject to increased ambient conditions from external infrared radiation.
5. A component designated only for use in a portable sign and is designated for use in a damp location is considered to include being installed in a damp or wet location sign outdoors where subject to increased ambient conditions from external infrared radiation.
6. A component identified for use without regard to a particular type of illumination in a sign shall comply with the most stringent requirements for all types of illumination.

Table 2.4 Continued on Next Page

Table 2.4 Continued

Installation Type				Location Designation			Type of Sign Illumination				Flammability		Min. RTI	UV
*P	Portable			Dry	Damp	Wet	*I	*F	HID	LED	Any V Rating	5 VA Rating		
	Table Top	Wall only	Wall and Pendant or Pendant Only											
<p>7. A component limited to being used in only portable wall type signs in a dry location is considered to be limited to locations where NOT subject to increased ambient conditions from external infrared radiation.</p> <p>8. A component designated for use in a portable combination wall and pendant, or pendant only installation type sign, designated for use in a dry location is considered to be subject to installation in windows where increased ambient conditions from external infrared radiation exist.</p> <p>9. The minimum Relative Temperature Index (RTI) is the maximum measured temperature determined in accordance with the Normal Temperature Test, 3.4.2.3. Where +15°C (27°F) is specified, the minimum RTI shall be 15°C (27°F) higher than the maximum measured temperature normalized to 25°C (45°F) to represent a higher ambient typical for certain types of signs.</p> <p>10. A component with no design limitation or instruction limitation for the type of illumination provided in a sign into which the component may be installed, shall have a polymeric material that is UV rated.</p> <p>11. Flammability – All V Type is inclusive of flammability ratings of V-2, V-1, V-0 and 5-VA and B.</p> <p>12. UV – Identifies a resistance to ultraviolet radiation rating for materials subject to ultraviolet radiation from the light source and/or external sources.</p>														

ULNORM.COM : Click to view the full PDF of UL 879 2012

2.1.4.3 The minimum temperature rating for a polymeric enclosure material determined in accordance with the standard for Polymeric Materials – Long Term Property Evaluations, UL 746B shall be the highest temperature of either:

- a) The Relative Thermal Index Based Upon Historical Record; or
- b) The Relative Thermal Index (RTI) with impact Based Upon Long-term Thermal-Aging Programs.

Table 2.5

Relative thermal indices based upon past field-test performance and chemical structure

Table deleted

2.1.4.4 The flammability rating of a polymeric enclosure material shall be determined as specified below:

- a) By the Standard for Tests for Flammability of Plastic Materials for Parts in Devices and Appliances, UL 94; or
- b) By the Self Extinguishing 5VA testing procedure in [3.2.2.1.3](#), or the Self Extinguishing V-2 testing procedure in [3.2.2.1.2](#) as appropriate for the minimum flammability rating.

2.1.4.5 A thermoplastic type potting material that fully encapsulates live parts and also functions as an enclosure shall have a minimum flammability rating of V-2.

2.1.4.6 A polymeric enclosure material located within 0.8 mm (0.032 in) of any uninsulated live part or within 13 mm (0.5 in) of any unenclosed mechanical contacts that make and break current, including the brush contacts of motors shall:

- a) Have a minimum PLC rating for hot-wire ignition (HWI) of 2, or comply with the Hot-Wire Ignition Test specified in [3.2.2.3](#) or the Glow-Wire End Product Test in [3.2.2.4](#), and
- b) Have a minimum PLC rating for high-current arc resistance to ignition rating (HAI) of 2, or comply with the High-Current Arc Ignition Test of [3.2.2.5](#) or the End-Product Arc Resistance Test of [3.2.2.6](#).

2.1.4.7 A polymeric enclosure material shall have a minimum PLC rating for comparative tracking index (CTI) of 1, or comply with the Comparative Tracking Index Performance Level Index Test specified in [3.2.2.2](#).

2.2 Insulating barrier

2.2.1 Where a glass material is provided to function as an insulating barrier in direct contact with live parts over 1000 V, shall be of borosilicate glass and have no metal content such as lead or iron.

2.2.2 A polymeric material in direct contact with live parts that functions as an insulating barrier shall:

- a) Have a flammability rating of at least HB or comply with the HB Testing Procedure specified in [3.2.2.1.4](#);
- b) Have a temperature rating equal to or greater than its maximum operating temperature in the component;
- c) For molded or formed thermoplastic parts, comply with the Mold Stress Relief Distortion Test of [3.4.1.1](#); and

d) Have a HWI (Hot wire Ignition), HAI (High Ampere Ignition) and CTI (Comparative Tracking Index) PLC values not greater than 2. A thermoset material such as epoxy is not required to have a HWI, HAI or CTI PLC rating.

2.3 Accessibility barrier

2.3.1 The following shall be made inaccessible to contact during normal use and user servicing by a material that complies with [2.3.3](#) – [2.3.6](#). Inaccessibility shall be judged in accordance with [2.3.2](#).

- a) All uninsulated current-carrying parts having voltages in excess of 15 Vrms (21.2 Vpeak) in a component identified for use in a damp or wet location;
- b) All uninsulated current carrying parts having voltages in excess of 30 Vrms (42.4 Vpeak) in a component identified for use in a dry location;
- c) All current carrying parts having insulation less than 0.71-mm (0.028-in) thick and a continuous operating voltage of 600 V or less;
- d) All insulated current carrying parts having a continuous operating voltage of greater than 600 V;
- e) All splices in wiring having a voltage in excess of 15 Vrms (21.2 Vpeak) in a component identified for use in a damp or wet location and in excess of 30 Vrms (42.4 Vpeak) in a component identified for use in a dry location;
- f) Any moving parts that could result in physical injury to a user, such as laceration, puncture or abrasion; and
- g) Dead metal parts that are at a risk of being energized and are not grounded.

2.3.2 A part required to be inaccessible in accordance with [2.3.1](#) shall not be able to be contacted by the articulate probes shown in [Figure 2.1](#) or [Figure 2.2](#). All neon tubing and lamps are to be installed as intended when determining compliance with accessibility requirements. The probe is to be applied to any depth that an opening will permit and with a force not greater than 4.4 N (1 lb). The probe is to be rotated or angled before, during, and after insertion through an opening to any position that is necessary to examine the part. The probe is to be applied in any possible configuration, and, if necessary, the configuration is to be changed after insertion through an opening.

Figure 2.1
Articulate probe with web stop

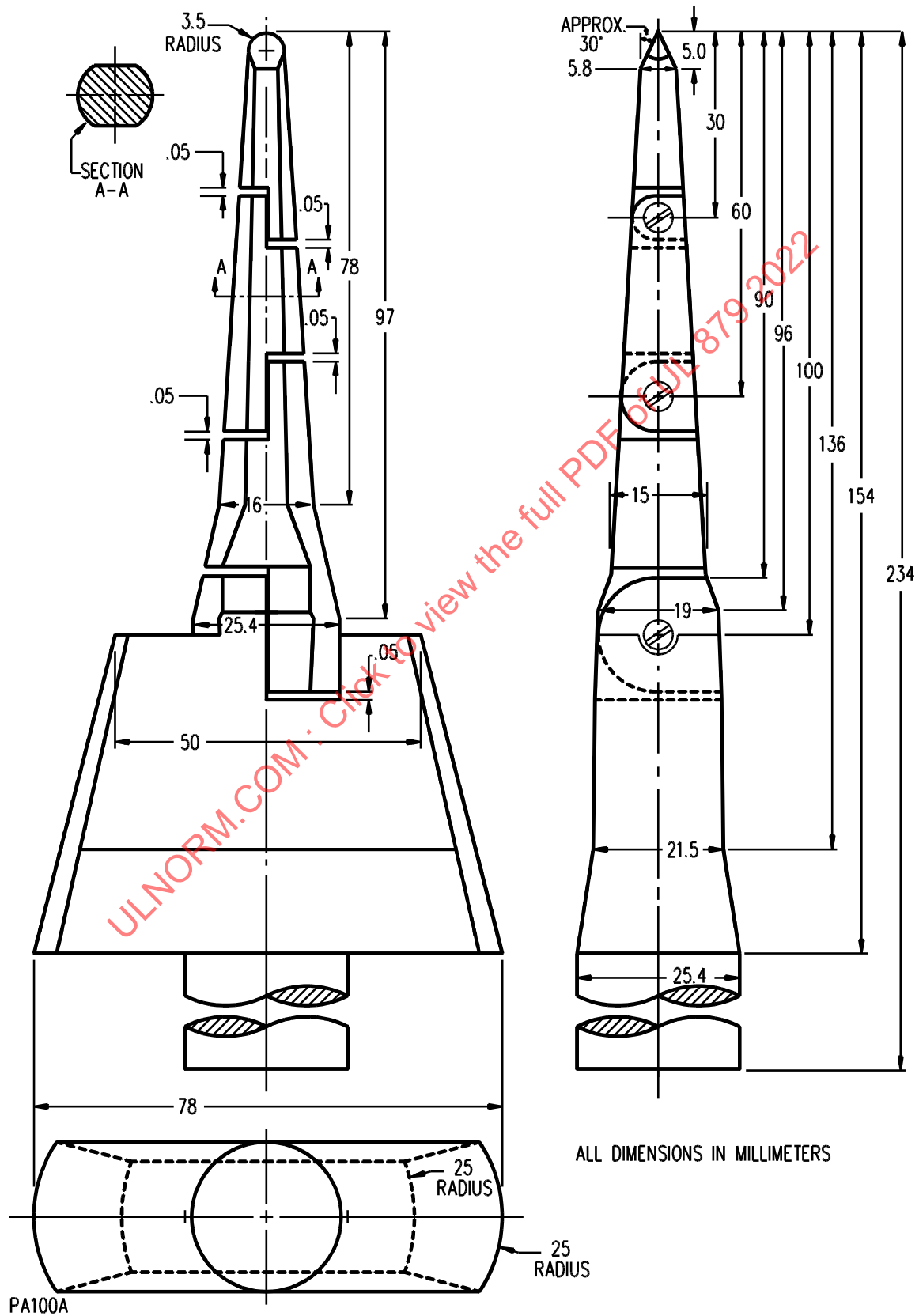
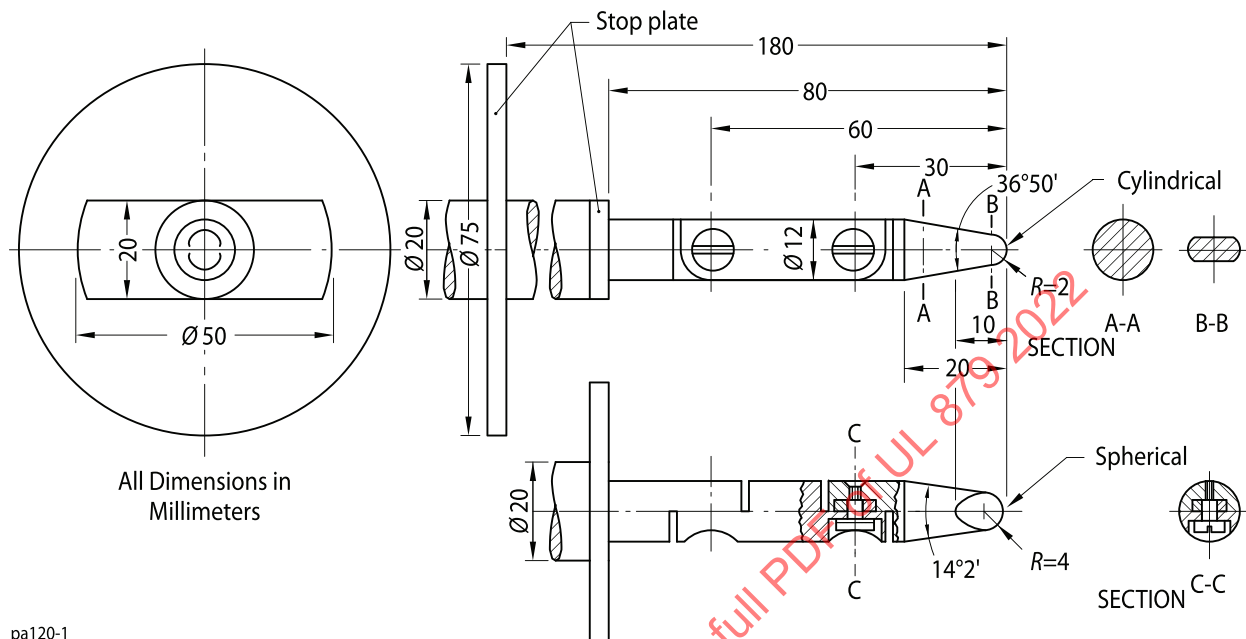

Figure 2.2

International Electrotechnical Commission (IEC) articulate accessibility probe with stop plate
courtesy of IEC



2.3.3 A material that prevents access to a part that is required to be inaccessible in accordance with [2.3.1](#) and [2.3.2](#) shall be constructed of:

- Metal (ferrous, aluminum, brass, zinc, or copper), minimum 0.41-mm (0.016-in) thick;
- Glass, porcelain, or ceramic, minimum 3.2-mm (1/8-in) thick;
- Impregnated glass fiber sleeving minimum 0.25-mm (0.01-in) thick, that is rated for the temperature involved;
- Vulcanized fiber, minimum 0.71-mm (0.028-in) thick; or
- Polymeric material that complies with the applicable requirements in [2.3.5](#) and [2.3.6](#).

2.3.4 An accessibility barrier used to make live parts inaccessible shall be subjected to the dielectric voltage withstand tests specified in [3.4.2.5](#) while the barrier is being subject to the accessibility barrier test specified [3.4.1.7](#). The dielectric voltage withstand tests shall be applied between live parts and the user or service personnel side of the barrier to include the combination of barrier material, spacing between the barrier and live parts, and any other material between live parts and the user or service personnel side of the barrier. The dielectric withstand voltage shall be based on the operating voltage to ground of the live parts being made inaccessible.

2.3.5 A polymeric material used to form an accessibility barrier to prevent access to uninsulated live parts having a maximum voltage of 1000 Vrms or less shall comply with the following material requirements. A polymeric material used to prevent access to insulated and uninsulated current carrying parts in excess of 1000 Vrms (1414 Vpeak) to ground shall also comply with [2.3.6](#).

- a) A polymeric material shall have a Relative Temperature Index that exceeds the maximum operating temperature of the barrier as measured by the Normal Temperature Test specified in [3.4.2.3](#);
- b) A polymeric material shall have a minimum flammability rating of minimum HB for the thickness provided or, for material with a thickness that is less than required for the flammability rating, comply with the Slow Burning HB Testing Procedure specified in [3.2.2.1.4](#);
- c) A polymeric material shall have a maximum PLC of 3 for hot wire ignition (HWI) and a maximum PLC of 3 for high-ampere arc ignition (HAI); and
- d) Comply with the Mold Stress Relief Distortion Test of the Standard for Polymeric Materials – Use in Electrical Equipment Evaluations, UL 746C.

2.3.6 A polymeric material provided to serve as an accessibility barrier preventing contact with insulated and uninsulated current carrying parts exceeding 1000 Vrms (1414 Vpeak) to ground, shall comply with the following:

- a) The spacing requirements in accordance with [2.15](#); or
- b) Comply with Material Dielectric Voltage Withstand Test specified in [3.2.2.16](#) or the test requirements in [2.3.4](#).

2.4 Openings and open holes

2.4.1 Open holes

2.4.1.1 An open hole in a material that encloses live parts or makes live or moving parts inaccessible shall:

- a) Not permit contact with insulated and uninsulated current carrying parts when the Accessibility Probe is applied as specified in [2.4.1.6](#);
- b) Not be larger than the dimensions specified in [Table 2.6](#), unless provided with a baffle in accordance with [2.4.1.5](#).
- c) Not be located in the enclosure of an open core and coil ballast or transformer unless the enclosure has only one likely orientation when mounted or installed and is baffled or louvered to prevent the potential escape of molten material while in that orientation.

Table 2.6
Maximum size of miscellaneous open holes

Opening shape	Maximum dimension		Maximum area	
	mm	(in)	mm ²	(in) ²
Slot	9.6	.375	9.68	1.5
Slot between two assembled parts	0.8	0.031	None	None
Square	12.7	0.5 width	None	None
Round	12.7	0.5 diameter	None	None
Irregular	12.7	0.5 per side	9.68	1.5

2.4.1.2 Open holes provided for draining moisture from a component intended for use in damp or wet locations shall be free of burrs. Circular drainage holes shall have a diameter of 6.4 – 12.7 mm (1/4 – 1/2

in). When not circular such holes shall have a minimum dimension of not less than 6.4 mm (1/4 in) and an area of 32.2 – 129.0 mm² (0.05 – 0.20 in²).

2.4.1.3 A hole for drainage shall be located in the bottom of the component or at the bottom edge of the back surface of the component. The location of the hole for drainage of water shall not be located where drainage is likely to occur onto other live parts when installed in a sign.

2.4.1.4 In a damp or wet location component, a horizontal surface that forms a trough shall be provided with one or more drain holes when a trough is arranged, formed, or located so that water pockets are not formed.

2.4.1.5 An open hole having dimensions larger than those specified in [Table 2.6](#) is permitted when the open hole is baffled in accordance with [Figure 2.3](#) to reduce access to live or moving parts.

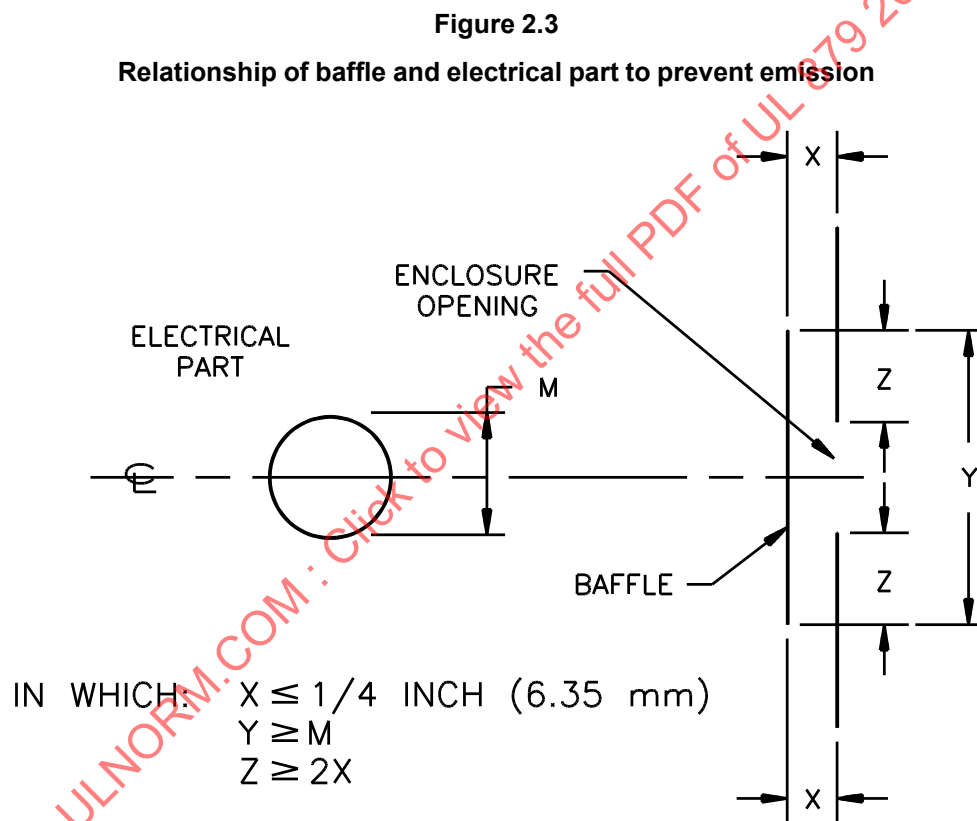

S3373

2.4.1.6 The probes referenced in and illustrated in [Figure 2.1](#) and [Figure 2.2](#) are to be applied to any depth that the open hole will permit, and shall be rotated or angled before, during, and after insertion through the open hole to any position that is necessary to examine the enclosure. The probe shall be applied in any possible configuration; and, if necessary, the configuration shall be changed after insertion through the open hole. The probe shall be used as measuring instruments to judge the accessibility provided by an open hole, and not as instruments to judge the strength of a material. They shall be applied with the minimum force necessary to determine accessibility.

2.4.2 Openings

2.4.2.1 A cover over an open hole in an enclosure shall be provided with means (such as screws, spot welding, interlock tangs and the like) to firmly secure it in place. Friction alone is not sufficient.

2.4.2.2 A knockout shall be adequately secured and yet removable without undue deformation of the enclosure as determined by compliance with the Knockout Test as described in [3.4.1.2](#).

2.4.2.3 If more than one open hole is provided for the supply and output connections, all but one of the open holes shall be covered such that they exist as either knockouts or covered open holes.

2.4.2.4 A knockout provided over a supply or output conduit open hole shall completely cover the opening in which it is located and the clearance between the cover and the opening shall be no more than 0.25 mm (0.010 in) before painting. The knockout thickness shall comply with the enclosure requirements.

2.5 Sign body

2.5.1 Polymeric material of a component to be installed on a wet location end use product and relied upon to prevent the wetting of insulated current carrying parts during the Rain Test in [3.4.1.9](#) shall comply with one of the following:

a) Ultraviolet Radiation Exposure Conditioning in [3.2.1.5](#) followed by the Impact Test specified in [3.4.1.6](#); or,

b) Ultraviolet Light Exposure Test of the Standard for Polymeric Materials – Use in Electrical Equipment Evaluations, UL 746C.

2.6 Gaskets and bushings

2.6.1 A gasket or bushing required to prevent water from entering an enclosure of splices, outdoor ballast, switch, or contact current carrying parts, including conductors, shall be secured to prevent its loosening during user maintenance by a clip, clamping ring, adhesive, or other mechanical means.

2.6.2 A gasket or bushing shall be made of neoprene or rubber composition gasket materials having a temperature rating suitable for the operating temperature as determined by the normal temperature test of [3.4.2.3](#) or shall withstand the flexibility and hardness test in [3.2.2.10](#).

2.6.3 The adhesive used to secure a gasket or bushing that is required to prevent water from entering the enclosure, and which is likely to be exposed or not compressed as intended during user maintenance, shall comply with the material adhesion test of [3.4.1.13](#).

2.7 Corrosion protection

2.7.1 All surfaces of ferrous metal parts including welds other than stainless steel and parts specified in [2.7.2](#), including hinges, bolts and fasteners, shall be protected against corrosion by galvanizing, painting, plating, corrosion resistant coating or enamel.

2.7.2 Laminations and other parts of iron or steel such as washers and screws that do not serve as an enclosure, accessibility barrier, water shield, or current-carrying part, are permitted without additional corrosion protection.

2.7.3 Edges and punched holes in prefinished steel, and hanger locations for painting or plating in ferrous metal, do not require any corrosion protection.

2.8 Mechanical joints and fastenings

2.8.1 The method of making a joint shall:

- a) Provide strength and rigidity and prevent turning that would result in movement of conductors or wiring devices after the assembly is completed and;
- b) Not result in reduction of spacings, loosening or displacement of parts, or other serious defects that causes a product to no longer comply with the requirements in this standard.

2.8.2 Adhesive relied upon to comply with enclosure, sign body, and accessibility barrier requirements and at any other location where the reliability of the securement means will affect a potential hazard, shall be rated for the surfaces and under the conditions specified in accordance with the Standard for Polymeric Materials – Use in Electrical Equipment Evaluations, UL 746C or comply with the Material Adhesion Test in [3.4.1.13](#).

2.8.3 Solvent, ultrasonic welding, electromagnetic induction, and thermal welding are acceptable means of securement.

2.8.4 Thread-forming screws shown in [Figure 2.4](#) shall not be used to secure a cover or component or be utilized as a terminal type screw that will be removed or replaced during field servicing.

2.8.5 Self-threading and sheet metal screws used to secure electrical or enclosure component parts in place, or together, shall comply with the Self-threading Screw Torque Test in [3.4.1.4](#), when the screw threads into non-ferrous metal or polymeric materials.

2.8.6 Self-threading and sheet metal screws used for mounting or supporting a part that weighs more than 3.4 kg (7.5 lb) per screw shall comply with the Self-threading Screw Torque Test in [3.4.1.4](#).

2.8.7 Self-threading and sheet metal screws shall not have the threads extend into a wiring compartment more than 5 mm (0.2 in) unless all conductors are reliably positioned away from the projecting screws or the conductors are stranded and sufficiently loose to prevent damage to the insulation.

Figure 2.4
Thread-forming screw

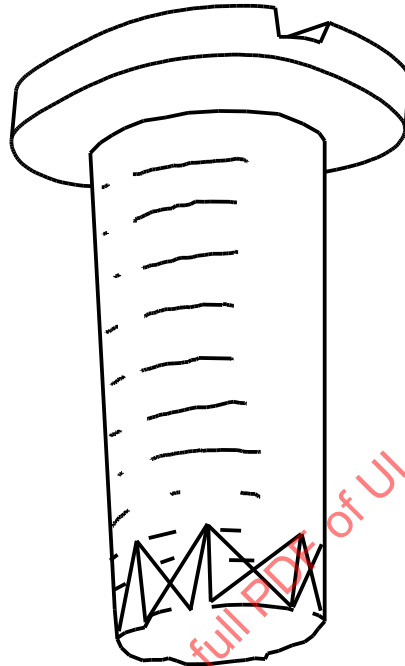

S3710

2.9 Sharp edges

2.9.1 An edge, projection, or corner of an enclosure, frame, barrier, guard, or the like, that is accessible to contact during and after installation or as part of user maintenance and servicing, shall not be sufficiently sharp to cause a cut-type injury when contacted during installation, intended use, or maintenance. An edge that has been smoothed or rounded to at least 120° back on itself is acceptable.

2.10 Supply connections

2.10.1 Permanently connected components

2.10.1.1 A sign component intended to be permanently installed shall have one of the following provisions for connection as follows:

- a) Be provided with means for connection to a source of supply in accordance with [2.10.2](#) for branch circuit supply connected components, or
- b) Be provided with leads or terminals for factory installation only.

2.10.2 Branch circuit supply connections

2.10.2.1 An electrical component intended for connection in accordance with the National Electrical Code shall have connection means that comply with [2.10.2.2](#) – [2.10.2.9](#) and either field wiring leads that comply with [2.10.4.1](#) – [2.10.4.1](#) or field wiring terminals that comply with [2.10.5.1](#) – [2.10.5.3](#).

2.10.2.2 Acceptable means for connection to a permanent wiring system shall be by providing an opening for conduit connection.

2.10.2.3 Unthreaded openings for conduit and the area surrounding the opening shall comply with the requirements in [Table 2.7](#).

Table 2.7
Dimensions of unthreaded opening for conduit and diameter of the area surrounding the opening

Nominal trade size of conduit	Unthreaded opening diameter ¹⁾		On interior of component, minimum unobstructed diameter of flat surface surrounding conduit opening	
	in	mm	mm	(in)
1/2	22.2	(0.875)	29.09	(1.11)
3/4	28.2	(1.109)	34.04	(1.34)
1	34.9	(1.375)	42.85	(1.69)
1 1/4	44.0	(1.734)	55.07	(2.14)

¹⁾ A plus tolerance of 0.82 mm (0.032 in) and a minus tolerance of 0.38 mm (0.015 in) applies to the knockout diameter. Knockout diameters are to be measured other than at points where a tab attaches the knockout.

2.10.2.4 A threaded opening for conduit shall comply with [Table 2.8](#) and have one of the following configurations:

- a) When tapped all the way through, the opening shall have at least 3.5 threads but no more than 5 threads and comply with the minimum unobstructed diameter of flat surface in [Table 2.7](#) to accommodate the conduit bushing; or
- b) When not tapped all the way through, the opening shall have at least 5 threads.

Table 2.8
Throat diameters for conduit openings

Nominal trade size of conduit	Minimum throat diameter		Maximum throat diameter	
	in	mm	mm	(in)
1/2	13.4	(0.528)	15.8	(0.622)
3/4	17.7	(0.697)	20.8	(0.819)
1	22.4	(0.882)	26.7	(1.051)
1-1/4	29.7	(1.169)	35.1	(1.382)

2.10.2.5 A component provided with a means of conduit connection shall be shipped with provision to close all but one of the conduit openings.

2.10.2.6 Unless provided with a wiring compartment as specified in [2.10.2.7](#), an opening provided for the purpose of making field connections to a branch circuit supply, shall not be located within 152 mm (6 in) of the following:

- a) Uninsulated live parts,
- b) Low voltage circuitry,
- c) Heat producing components,

d) Moving parts, and

e) Any electrical or mechanical component not specifically identified above that could result in an increased risk of fire or shock.

2.10.2.7 The area adjacent to an opening where branch circuit supply connections are to be made in the field and which has components located within 152 mm (6 in) of the opening, shall be enclosed within a wiring compartment having a volume of at least 98 cm³ (6 in³).

2.10.2.8 A field-wiring compartment intended for connection of a wiring system shall be attached to the product so that it will be prevented from turning.

2.10.2.9 An outlet box, terminal box, wiring compartment, or the like in which connections to the product will be made in the field shall be free from any sharp edge, including screw threads, a burr, a fin, a moving part, or the like, that may abrade the insulation on conductors or otherwise damage the wiring.

2.10.3 Field-wiring leads

2.10.3.1 A field wiring lead shall be of wire that complies with [2.12.3](#) and is no smaller than 18 AWG (0.82 mm²).

2.10.3.2 The free length of a field wiring lead shall be 15.2 cm (6 in) or more. Where a wiring compartment is provided, the free length is measured from the point of entry of the lead into the wiring compartment to the free end.

2.10.3.3 The insulation of a lead intended for the connection of a grounded conductor (common or neutral) shall be white or gray throughout its length.

2.10.3.4 The insulation of a lead intended for the connection of an ungrounded (hot) conductor shall be any color other than white, gray, green, or green with yellow stripe.

2.10.3.5 Strain relief shall be provided on field wiring leads so that stress on a lead will not be transmitted to the electrical connection inside a product. The acceptability of the strain relief means shall be determined by the Strain Relief Test specified in [3.4.1.3](#).

2.10.3.6 The insulation of a lead intended for the connection of a grounding conductor shall be green, or green with yellow stripe.

2.10.4 Field-wiring terminals

2.10.4.1 A pressure wire type terminal or a wire binding screw shall be of the type suitable for field wiring.

2.10.4.2 A terminal intended for connection of a grounded conductor of an ac supply shall be metal substantially white or silver in color or be marked in format S32-L3 with the words "NEUTRAL", "N", "W" or "White". No other terminal shall be substantially white or silver in color.

2.10.4.3 A terminal intended for connection of a dc supply where polarity of the supply connection is required shall be marked in format S32-L3 with the symbols "-" and "+" on or immediately adjacent to the supply terminals.

2.10.4.4 The integrity of the wire connection shall not rely on the dimensional stability of thermoplastic material unless the material has been evaluated for mechanical strength, resistance to impact, moisture absorptive properties, combustibility, resistance to arching, resistance to temperatures to which the

material is subject to under normal operating use, aging characteristics and those applicable requirements in the Standard for Polymeric Materials-Use in Electrical Equipment Evaluations, UL 746C.

2.10.5 Detachable and non-detachable cord-connected and direct plug-in

2.10.5.1 A sign component that is not intended to be permanently connected to a source of supply shall be provided with only one means of connection to the source of supply and shall be designated for use only in a portable end product and be provided with one of the following means of supply connection:

- a) A component intended to be provided with a non-detachable type power supply cord shall have the cord permanently installed on the component,
- b) A component intended to be provided with a detachable power supply cord shall be provided with an attachment cap having recessed male contacts, or
- c) A component intended to be provided with a direct plug-in unit shall be provided with the appropriate type of connector to mate with the connector provided on the output cord of the direct plug-in unit.

2.10.5.2 Unless a component complies with [2.10.5.6](#), a non-detachable power supply cord and a connector for a detachable supply cord shall be of the grounding (three-conductor) type.

2.10.5.3 A component that is provided with a non-detachable power supply cord shall employ a polarized or grounding-type attachment plug as shown in [Figure 2.5](#).

2.10.5.4 A component that is provided with a detachable power supply cord shall employ a attachment cap that is polarized or of the grounding-type attachment type that will accommodate the configurations shown in [Figure 2.5](#).

Figure 2.5

Connection to attachment plug

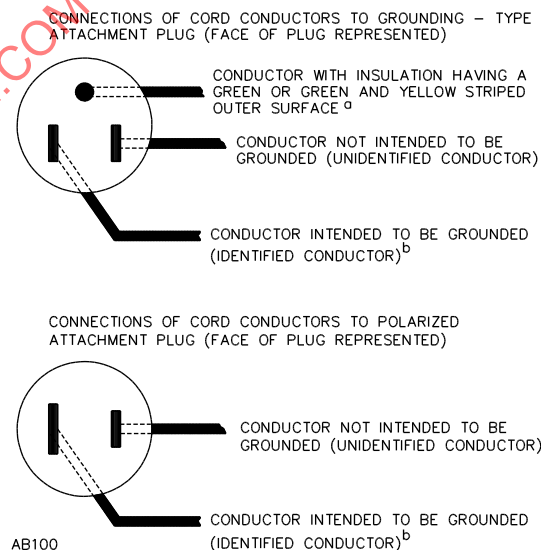

Notes to Figure 2.5:

- a) In the figure, the blade to which the green conductor is connected may have a U-shaped or a circular cross section.
- b) In the figure, the identified conductor is the conductor that is intended to be grounded.

2.10.5.5 A three-conductor flexible cord with ground shall be provided with conductor identification to identify grounded and grounding conductors. A jacketed cord such as a SJT type shall have the grounding conductor within the jacket colored green or green with a yellow stripe and the grounded conductor shall be colored white or gray.

2.10.5.6 A component with no accessible dead-metal parts is not required to be provided with a supply cord of the grounding type, when marked in accordance with [2.16.6](#).

2.10.5.7 When a two-conductor flexible cord is provided for connection to the source of supply and polarity is required in accordance with [2.14.2](#), the conductors shall be connected to a polarized parallel-blade attachment plug with the identified grounded conductor (neutral) connected to the wider blade. A parallel cord such as Type SPT-2 shall have a stripe, ridge, or groove on the exterior of the cord surface of the grounded (neutral) conductor for identification.

2.10.5.8 A power supply cord shall be minimum 18 AWG (0.82 mm²).

2.10.5.9 The power supply cord provided on a sign component designated for dry location only shall be Type SP-2, Type SPE-2, Type SPT-2, or heavier. The power supply cord on a sign component designated for damp or wet locations, shall be of Type SO or harder usage and designated for outdoor use by a surface marking "W" or "Water Resistant".

2.10.5.10 All detachable and non-detachable supply cords shall be minimum 1.83 m (6 ft) and maximum 4.57 m (15 ft) in length. A non-detachable supply cord that is less than 1.83 (6 ft) in length and no less than 0.33 m (1 ft) in length is acceptable when the sign component is designated only for use in wall-mounted or hanging signs. The length shall be measured from the point where the cord emerges from the sign component, or after any strain-relief means provided, to the point where the cord enters an attachment plug.

2.10.5.11 Strain and push-back relief shall be provided to reduce the risk of mechanical stress on the power supply cord from being transmitted to terminals, splices, or interior wiring. The strain-relief means shall be evaluated by the Strain Relief Test, [3.4.1.3](#).

2.10.5.12 Where a knot in a flexible power supply cord serves as strain relief, the surface(s) upon which the knot contacts or bears shall not have burrs, fins, sharp edges, and projections that could damage the insulation on a cord.

2.10.5.13 Flexible supply cords shall be provided with a bushing at the point where the cord passes through an opening in a metal enclosure or through a non-rounded opening of a polymeric enclosure. The bushing shall be secured in place and have a smooth, rounded surface against which the cord bears. The bushing shall be an insulating type if the cord is Type SVT or lighter.

2.10.5.14 The attachment plug of a cord-connected sign component shall be rated for a 15- or 20-A branch circuit. An attachment plug of a cord-connected sign component that supplies a neon circuit is permitted to be rated 30 A maximum.

2.10.5.15 The ampacity of the attachment plug of a power supply cord shall not be less than 125% of the input rating.

2.11 Equipment grounding and bonding

2.11.1 Parts required to be grounded

2.11.1.1 A dead metal part not intended to be electrically live is required to be conductively connected to ground in accordance with [2.11.1.4](#) unless the part is identified as not having a potential to become inadvertently energized in accordance with [2.11.1.2](#) or parts identified in [2.11.1.3](#).

2.11.1.2 A dead metal part is not considered to have a potential to become inadvertently energized when:

- a) The dead metal part is within a compartment that contains an insulated or uninsulated live part and the insulated or uninsulated live part is located and reliably secured to provide the spacings required in [2.15](#).
- b) The dead metal part is separated from insulated and uninsulated live parts by a rigid insulating material at least 3.2-mm (0.125-in) thick.
- c) The dead metal part is separated from insulated and uninsulated live parts by a material that complies with the Material Dielectric Voltage Withstand Test specified in [3.2.2.16](#).

2.11.1.3 The following parts are not required to be bonded to ground:

- a) Accessible non-current-carrying metal parts of components (for example, lampholders and switches) that are isolated from live parts;
- b) Decorative parts, metal guards, and metal shades that do not enclose live parts; and,
- c) Dead metal parts that enclose insulated or uninsulated live parts that are connected to a Class 2 power source that complies with [2.12.6.1](#); and
- d) A dead metal part such as an adhesive-attached metal foil marking plate secured to the outside of an enclosure and mounting hardware external to a sign component.

2.11.1.4 Conductive connection to ground shall be either through a direct connection to a branch circuit ground or through bonding to a point on the sign component that is capable of being connected to a branch circuit ground.

2.11.2 Provision for grounding

2.11.2.1 The grounding means required in [2.11.1.1](#) shall be in the same location as the supply connection means and shall consist of a grounding conductor lead, a terminal connector, a wire binding screw, or the equivalent as specified in [2.11.3.1](#).

2.11.2.2 A grounding connection wire binding screw or stud, or grounding lead shall be provided with a star washer or other fastening means that will penetrate a non-conductive coating such as paint.

2.11.2.3 A neutral (grounded conductor) shall not be connected to any grounding or bonding terminal or lead in or on the surface of a sign component.

2.11.2.4 A grounding terminal or lead shall not be located on a removable part, unless the removal of the part during user maintenance does not interrupt the bonding continuity.

2.11.2.5 A ground connection means including a grounding terminal and grounding lead securement screw or terminal shall not be used for any other purpose.