



UL 859

STANDARD FOR SAFETY

Household Electric Personal Grooming Appliances

ULNORM.COM : Click to view the full PDF of UL 859 2022

[ULNORM.COM](https://www.ulnorm.com) : Click to view the full PDF of UL 859 2022

UL Standard for Safety for Household Electric Personal Grooming Appliances, UL 859

Eleventh Edition, Dated June 20, 2012

Summary of Topics

This revision of ANSI/UL 859 dated November 11, 2022 includes the following changes in requirements:

– Clarification of Immersion Protection Requirements and Immersion Protection Trip Time Measurement Test; [5.4A](#), [5.20A](#), [5.25A](#), [7.1](#), [7.2](#), [7.5](#), [7.6](#), [7.8](#), [40.1.1](#) – [40.1.4](#), [40.2.1](#), [40.2.2](#), Sections [41](#), [42](#), [72.4.1](#) and [88.2](#)

– Clarification of Temperature Test for Hand Supported Hair Dryers; [44.1.2](#), [44.1.17](#) and [Table 54.1](#)

Text that has been changed in any manner or impacted by UL's electronic publishing system is marked with a vertical line in the margin.

The new and revised requirements are substantially in accordance with Proposal(s) on this subject dated September 23, 2022.

All rights reserved. No part of this publication may be reproduced, stored in a retrieval system, or transmitted in any form by any means, electronic, mechanical photocopying, recording, or otherwise without prior permission of UL.

UL provides this Standard "as is" without warranty of any kind, either expressed or implied, including but not limited to, the implied warranties of merchantability or fitness for any purpose.

In no event will UL be liable for any special, incidental, consequential, indirect or similar damages, including loss of profits, lost savings, loss of data, or any other damages arising out of the use of or the inability to use this Standard, even if UL or an authorized UL representative has been advised of the possibility of such damage. In no event shall UL's liability for any damage ever exceed the price paid for this Standard, regardless of the form of the claim.

Users of the electronic versions of UL's Standards for Safety agree to defend, indemnify, and hold UL harmless from and against any loss, expense, liability, damage, claim, or judgment (including reasonable attorney's fees) resulting from any error or deviation introduced while purchaser is storing an electronic Standard on the purchaser's computer system.

No Text on This Page

[ULNORM.COM](https://ulnorm.com) : Click to view the full PDF of UL 859 2022

JUNE 20, 2012
(Title Page Reprinted: November 11, 2022)



ANSI/UL 859-2022

1

UL 859

Standard for Household Electric Personal Grooming Appliances

The first, second, and third editions were titled Beauty-Parlor Equipment. The fourth, fifth, and sixth editions were titled Electric Personal Grooming Appliances.

First Edition – September, 1954
Second Edition – November, 1966
Third Edition – May, 1971
Fourth Edition – July, 1975
Fifth Edition – July, 1978
Sixth Edition – February, 1984
Seventh Edition – January, 1988
Eighth Edition – January, 1991
Ninth Edition – December, 1995
Tenth Edition – August, 2002

Eleventh Edition

June 20, 2012

This ANSI/UL Standard for Safety consists of the Eleventh Edition including revisions through November 11, 2022.

The most recent designation of ANSI/UL 859 as an American National Standard (ANSI) occurred on November 11, 2022. ANSI approval for a standard does not include the Cover Page, Transmittal Pages, and Title Page.

Comments or proposals for revisions on any part of the Standard may be submitted to UL at any time. Proposals should be submitted via a Proposal Request in UL's On-Line Collaborative Standards Development System (CSDS) at <https://csds.ul.com>.

UL's Standards for Safety are copyrighted by UL. Neither a printed nor electronic copy of a Standard should be altered in any way. All of UL's Standards and all copyrights, ownerships, and rights regarding those Standards shall remain the sole and exclusive property of UL.

COPYRIGHT © 2022 UNDERWRITERS LABORATORIES INC.

No Text on This Page

[ULNORM.COM](https://ulnorm.com) : Click to view the full PDF of UL 859 2022

CONTENTS

INTRODUCTION

1	Scope	7
2	Components	7
3	Units of Measurement	8
4	Undated References	9
5	Glossary	9

CONSTRUCTION

6	General	14
7	Hair Dryer Immersion Protection	15
8	Frame and Enclosure	20
	8.1 General	20
	8.2 Polymeric enclosures and parts	20
	8.3 Metal enclosures	20
	8.4 Corrosion resistance	21
	8.5 Accessibility of live parts	21
	8.6 Doors and covers	26
9	Reduction of Risk of Injury to Persons	26
	9.1 General	26
	9.2 Appliances with reservoirs	26
	9.3 Wax depilatory appliances	27
10	Mechanical Assembly	28
11	Stability	29
12	Hanging and Mounting Means	29
13	Supply Connections	30
	13.1 Permanently-connected appliances	30
	13.2 Wiring terminals	30
	13.3 Cord-connected appliances	32
	13.4 Strain relief	40
	13.5 Bushings	41
	13.6 Direct plug-in appliances	42
14	Live Parts	46
15	Reservoirs	46
16	Internal Wiring	46
17	Heating Element	49
18	Electrical Insulation	49
	18.1 General	49
	18.2 Film-coated wire (magnet wire)	50
19	Thermal Insulation	50
20	Overcurrent Protection	51
21	Thermal Cutoffs (Fusible Links)	51
22	Lampholders and Receptacles	51
23	Switches	52
	23.1 General	52
	23.2 Dual-voltage selector	54
24	Automatic Controls and Control Circuits	54
	24.1 General	54
	24.2 Electromechanical and electronic controls	56
25	Controls – End Product Test Parameters	56
	25.1 General	56
	25.2 Auxiliary controls	56

	25.3 Electronic Operating controls (regulating controls).....	57
	25.4 Electronic Protective controls (limiting controls).....	58
26	Spacings	60
	26.1 General.....	60
	26.2 Spacings on printed wiring boards.....	61
27	Grounding	61
28	Motors.....	62
	28.1 Construction.....	62
	28.2 Brush wear-out.....	62
	28.3 Overload protection	63
	28.4 Insulation systems	65
29	Transformers	65
30	Batteries and Battery Chargers.....	66
31	Capacitors	66
32	Light Sources and Associated Components	67
33	Ionization Circuits.....	67
33A	Button or Coin Cell Batteries of Lithium Technologies.....	68

PERFORMANCE

34	General	68
35	Strength of Enclosure Test	68
36	Tip-Over Test	69
37	Stability Test	69
38	Leakage Current Test	70
39	Leakage Current Test Following Humidity Conditioning	72
40	Immersion Protection Trip Time Measurement Test.....	72
	40.1 As-received hair dryers	72
	40.2 Conditioned hair dryers	74
41	Dew Point Humidity Test	75
42	Conductive Coating Test	75
43	Power Input Test	75
44	Normal Temperature Test.....	75
	44.1 All appliances	75
	44.2 Wax depilatory appliances.....	83
	44.3 Heated air curling irons and brushes	83
	44.4 Hair-drying appliances	86
	44.5 Hand-supported hair dryers	86
45	Dielectric Voltage-Withstand Test	89
46	Abnormal Operation Tests.....	89
	46.1 General.....	89
	46.2 Hair dryers – drape test.....	90
	46.3 Hair dryer locked rotor test.....	91
	46.4 Hand-supported hair dryers	91
	46.5 Dual-voltage appliances	94
	46.6 All appliances – short-circuit, stall tests.....	95
	46.7 Hair curler heater – short-circuit test.....	95
	46.8 Bonnet-type hair dryers – hair entanglement test.....	96
	46.9 Wax depilatory appliances.....	96
	46.10 Hair dryer immersion protective devices with convenience receptacles	97
	46.11 Appliances having an automatically-controlled preheat cycle	98
47	Exposure to Moisture Test.....	98
48	Strain Relief Test.....	99
49	Cord Flexing Test	99
50	Cord Flexing Test for Appliance Leakage-Current-Interrupter (ALCI)	101
51	Test for Security of Swivel Assembly	103

52	Swivel Endurance Test	103
53	Hinge Endurance Test	104
54	Test of Automatic Controls	104
	54.1 Overload	104
	54.2 Endurance	105
55	Test of Thermal Cutoffs (Fusible Links)	106
56	Motor Control Overload Test.....	106
57	Grounding Continuity Test.....	107
58	Test for Permanence of Cord Tag for Hand-Supported Hair-Drying Appliances.....	107
	58.1 General.....	107
	58.2 Test conditions	107
	58.3 Test method	108
59	Mounting Means Strength Test	108
60	Extended Operation Test.....	108
61	Heating Element Endurance Test.....	111
62	Test of Physical Properties of a Liquid Container, Seal, or Diaphragm.....	111
63	Label Adhesion Test (<i>Deleted</i>).....	112
64	Flammability Test – Wax for Depilatory Appliances.....	112
65	Additional Testing for Hand-Supported Grooming Appliances with a Detachable Power Supply Cord and for Hand-Supported Grooming Appliances with Detachable Parts Intended to be Disconnected From Power Under Load Conditions	113
66	Thermoplastic Motor Insulation Systems	115
	66.1 General.....	115
	66.2 Abnormal conditioning.....	116
	66.3 Overload-burnout conditioning.....	116
	66.4 Thermal aging	116
67	Ozone Test	118

MANUFACTURING AND PRODUCTION-LINE TESTS

68	Dielectric Voltage-Withstand Test.....	118
69	Grounding Continuity Test.....	120
	69.1 Continuity of grounding connection	120
	69.2 Electrical indicating device.....	121
70	Hair Dryer Power Input Test	121

RATINGS

71	Details.....	121
----	--------------	-----

MARKINGS

72	Details.....	122
	72.1 General.....	122
	72.2 Body- or table-supported hood- or bonnet-type hair dryers.....	123
	72.3 Dual-voltage appliances	123
	72.4 Hand-supported hair-drying appliances	123
	72.5 Permanently-installed wall-mounted hair dryers	125
	72.6 Curling irons.....	128
	72.7 Direct plug-in appliances	129
	72.8 Wax depilatory appliances.....	129
	72.9 Appliances with GFCIs or similar protective devices	130
	72.10 Convenience receptacle of a hand-supported hair dryer immersion protective device.....	130
	72.11 Hand-supported appliances with detachable power supply cords.....	130

INSTRUCTION MANUALS

73	General	130
74	Instructions Pertaining to a Risk of Fire, Electric Shock, or Injury to Persons	131
75	Installation Instructions	138
76	Operating Instructions.....	139
77	User-Maintenance Instructions	142

ELECTRODE-TYPE APPLIANCES

78	General	142
79	Construction	142
80	Operation Test	142
81	Leakage Current Test	143
82	Disassembly and Reassembly.....	145
83	Markings.....	145
84	Operating Instructions.....	146

WALL-HUNG HAIR DRYERS

85	Scope.....	146
86	General	146
87	Construction	146
88	Performance	147
89	Markings.....	147
90	Use and Care Instructions.....	147
91	Installation Instructions	148

SUPPLEMENT SA – HAIR DRYER ACCESSORIES

SA1	Scope	149
SA2	General.....	149
SA3	Markings	149
	SA3.1 General	149
	SA3.2 Hair dryer accessories	149
	SA3.3 Product packaging	149
	SA3.4 Instruction sheet	150
SA4	Instructions.....	151

INTRODUCTION

1 Scope

1.1 These requirements cover electric personal grooming appliances intended for household use, such as hair curlers and dryers, combs, brushes, and similar appliances to be used in accordance with the National Electrical Code, NFPA 70.

1.2 These requirements do not cover appliances rated more than 250 volts nor appliances covered in the following Standards for Safety:

- a) The Standard for Medical Electrical Equipment, Part 1: General Requirements for Safety, UL 60601-1;
- b) The Standard for Personal Hygiene and Health Care Appliances, UL 1431;
- c) The Standard for Household and Similar Electrical Appliances, Part 2: Particular Requirements for Shavers, Hair Clippers, and Similar Appliances, UL 60335-2-8;
- d) The Standard for Motor-Operated Massage and Exercise Machines, UL 1647;
- e) The Standard for Electric Heating Pads, UL 130; and
- f) The Standard for Commercial Electric Personal Grooming Appliances, UL 1727.

2 Components

2.1 A component of a product covered by this standard shall:

- a) Comply with the requirements for that component as indicated in the individual section(s) covering that component;
- b) Be used in accordance with its rating(s) established for the intended conditions of use;
- c) Be used within its established use limitations or conditions of acceptability;
- d) Additionally comply with the applicable requirements of this standard; and
- e) Not contain mercury, unless used within a fluorescent, high intensity discharge, or neon lamp bulb.

Exception No. 1: A component of a product covered by this standard is not required to comply with a specific component requirement that:

- a) Involves a feature or characteristic not required in the application of the component in the product;*
- b) Is superseded by a requirement in this standard; or*
- c) Is separately investigated when forming part of another component, provided the component is used within its established ratings and limitations.*

Exception No. 2: A component complying with a component standard other than those cited in this standard is acceptable if:

- a) The component also complies with the applicable component standard indicated in this standard; or*

b) *The component standard:*

- 1) *Is compatible with the ampacity and overcurrent protection requirements of the National Electrical Code, ANSI/NFPA 70, where appropriate;*
- 2) *Considers long-term thermal properties of polymeric insulating materials in accordance with the Standard for Polymeric Materials – Long Term Property Evaluations, UL 746B; and*
- 3) *Any use limitations of the other component standard is identified and appropriately accommodated in the end use application. For example, a component used in a household application, but intended for industrial use and complying with the relevant component standard may assume user expertise not common in household applications.*

2.2 Specific components are incomplete in construction features or restricted in performance capabilities. Such components are intended for use only under limited conditions, such as certain temperatures not exceeding specified limits, and shall be used only under those specific conditions.

2.3 A component that is also intended to perform other functions, such as:

- a) Overcurrent protection;
- b) Ground-fault circuit-interruption;
- c) Surge suppression;
- d) Any other similar functions; or
- e) Any combination thereof.

shall comply additionally with the requirements of the applicable UL standard(s) that cover devices that provide those functions.

Exception: Where these other functions are not required for the application and not identified as part of markings, instructions, or packaging for the appliance, the additional component standard(s) need not be applied.

2.4 A component not anticipated by the requirements of this standard, not specifically covered by the component standards noted in this Standard, and that involves a risk of fire, electric shock, or injury to persons, shall be additionally investigated in accordance with the applicable UL standard, and shall comply with [2.1](#) (b) – (e).

2.5 With regard to a component being additionally investigated, reference to construction and performance requirements in another UL standard is suitable where that standard anticipates normal and abnormal use conditions consistent with the application of this standard.

3 Units of Measurement

3.1 Values stated without parentheses are the requirement. Values in parentheses are explanatory or approximate information.

3.2 Unless otherwise indicated, all voltage and current values mentioned in this standard are root-mean-square (rms).

4 Undated References

4.1 Any undated reference to a code or standard appearing in the requirements of this standard shall be interpreted as referring to the latest edition of that code or standard.

5 Glossary

5.1 For the purpose of this standard the following definitions apply.

5.2 **APPLIANCE COUPLER** – A single-outlet, female contact device for attachment to a flexible cord as part of a detachable power-supply cord to be connected to an appliance inlet (motor attachment plug).

5.3 **APPLIANCE INLET (MOTOR ATTACHMENT PLUG)** – A male contact device mounted on an end product appliance to provide an integral blade configuration for the connection of an appliance coupler or cord connector.

5.4 **APPLIANCE (FLATIRON) PLUG** – An appliance coupler type of device having a cord guard and a slot configuration specified for use with heating or cooking appliances.

5.4A **APPLIANCE LEAKAGE-CURRENT INTERRUPTER (ALCI)** – A device intended to interrupt the electric circuit to the load, when a fault current to ground exceeds some predetermined value that is less than that required to operate the overcurrent protective device of the supply circuit.

5.5 **AUTOMATIC CONTROL** – A device intended for automatic control of operating time, temperature, or pressure under conditions of intended operation and not for protection against conditions resulting from abnormal operations.

5.6 **AUTOMATICALLY CONTROLLED APPLIANCE** – An appliance that complies with one or more of the following conditions:

- a) The repeated starting of the appliance is independent of any manual control if, after one complete cycle of operation, a limit device or similar component opens the circuit;
- b) During any single preset cycle of operation, the motor is caused to stop and restart;
- c) When the appliance is energized, the initial starting of the motor may be intentionally delayed beyond intended, conventional starting; and
- d) For an appliance using a motor with a separate starting winding, during any single predetermined cycle of operation, automatic changing of the mechanical load reduces the motor speed sufficiently to re-establish starting-winding connections to the supply circuit.

5.7 **BODY-SUPPORTED APPLIANCE** – An appliance that is physically supported by any part of the body, other than the hand of the user, during the performance of its intended functions (such as a shoulder-, body-, or head-supported hair dryer). Reference is to be made to the user manual of the appliance in establishing the intended functions of the appliance.

5.8 **CONTROL, AUTOMATIC ACTION** – A control in which at least one aspect is non-manual.

5.9 **CONTROL, AUXILIARY** – A device or assembly of devices that provides a functional utility, is not relied upon as an operational or protective control, and therefore is not relied upon for safety. For example, an efficiency control not relied upon to reduce the risk of electric shock, fire, or injury to persons during normal or abnormal operation of the end product is considered an auxiliary control.

5.10 CONTROL, MANUAL – A device that requires direct human interaction to activate or reset the control.

5.11 CONTROL, OPERATING – A device or assembly of devices, the operation of which starts or regulates the end product during normal operation. For example, a thermostat, the failure of which a thermal cutout/limiter or another layer of protection would mitigate the potential hazard, is considered an operating control. Operating controls are also referred to as “regulating controls”.

5.12 CONTROL, PROTECTIVE – A device or assembly of devices, the operation of which is intended to reduce the risk of electric shock, fire or injury to persons during reasonably anticipated abnormal operation of the appliance. Protective controls are also referred to as “limiting controls” and “safety controls.”

Note – During the evaluation of the protective control/circuit, the protective functions are verified under normal and single-fault conditions of the control.

5.13 CONTROL, TYPE 1 ACTION – The actuation of an automatic control for which the manufacturing deviation and the drift (tolerance before and after certain conditions) of its operating value, operating time, or operating sequence has not been declared and tested under this standard.

5.14 CONTROL, TYPE 2 ACTION – The actuation of an automatic control for which the manufacturing deviation and the drift (tolerance before and after certain conditions) of its operating value, operating time, or operating sequence have been declared and tested under this standard.

5.15 CORD CONNECTOR – A female contact device wired on flexible cord for use as an extension from an outlet to make a detachable electrical connection to an attachment plug or, as an appliance coupler, to an equipment inlet.

5.16 COUNTER-SUPPORTED APPLIANCE – An appliance that is physically supported by a counter, table, or bench during the performance of its intended functions (such as a bonnet-type hair dryer). Reference is to be made to the user manual of the appliance in establishing the intended functions of the appliance.

5.17 DIRECT PLUG-IN APPLIANCE – An appliance, without a power supply cord, that is physically supported by direct insertion of its integral blades into a receptacle.

5.18 DUAL-VOLTAGE APPLIANCE – An appliance rated for use at 120 or 240 volts and provided with a means to change from one voltage to the other.

5.19 FIXED APPLIANCE – An appliance intended to be permanently connected electrically.

5.20 FLOOR-SUPPORTED APPLIANCE – An appliance that is physically supported by the floor during the performance of its intended functions (such as hair dryers with roll-about stands). Reference is to be made to the user manual of the appliance in establishing the intended functions of the appliance.

5.20A GROUND-FAULT CIRCUIT-INTERRUPTER (GFCI) – A device intended for the protection of personnel that functions to de-energize a circuit, within an established period of time, when a fault current to ground, exceeds some predetermined value, that is less than that required to operate the overcurrent protective device of the supply circuit.

5.21 HAIR CRIMPING IRON – A hand-supported hair curling appliance having hinged arms and ridged or wavy surfaced electrically heated tongs between which hair is placed. A typical construction is shown in [Figure 5.1](#).

Figure 5.1
Typical hair crimping iron

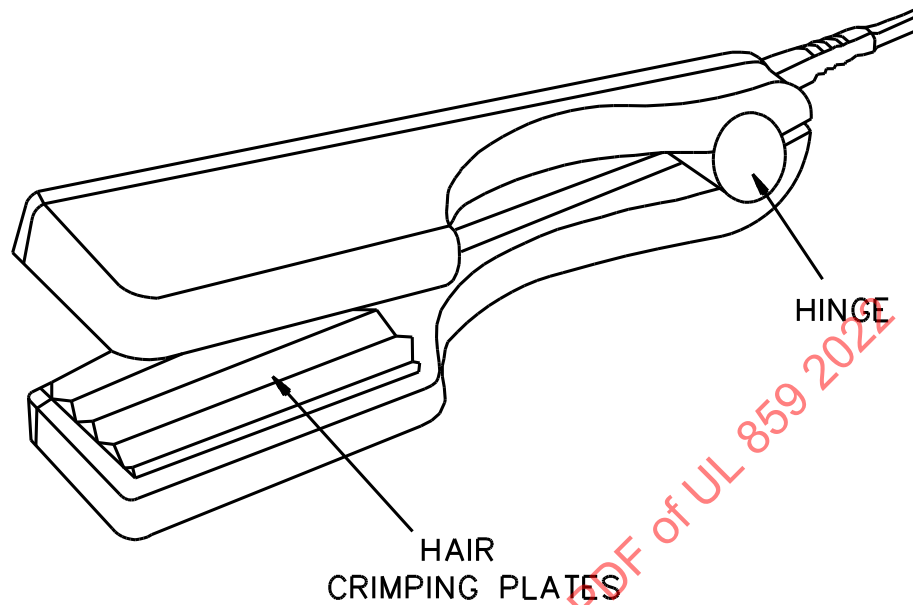

S3516

5.22 HAIR CURLER HEATER (HAIR SETTER) – A counter-supported appliance having posts or wells on or in which hair curling devices (such as rollers) are heated before being applied to the hair. The term also applies to a construction that has individual electrical hair curlers (rollers) with built-in heating elements and male electrical fittings which plug into female contacts in the appliance.

5.23 HAIR STRAIGHTENING IRON – An appliance similar to a hair crimping iron described in [5.21](#) except that the hair crimping plates are replaced with flat plates.

5.24 HAND-HELD APPLIANCE/HAND-GUIDED APPLIANCE – A portable appliance that during intended use is contacted by the hand of the user for purposes of electrical or physical control but not for complete support.

5.25 HAND-SUPPORTED APPLIANCE – An appliance that is physically supported by the hand of the user during the performance of its intended functions (such as a curling iron). Reference is to be made to the user manual of the appliance in establishing the intended functions of the appliance.

5.25A HAND-SUPPORTED HAIR DRYING APPLIANCE – An hand supported appliance noted in [5.22](#), intended to blow or dry wet hairs and may include additional hair styling functions. Hand supported hair drying appliance includes hair dryer, blower-styler, heated air comb or brush, heated-air curler, heated-air curling iron, curling iron-hair dryer combination, a wall hung hair dryer or the hand unit of a wall-mounted hair dryer, or similar appliance.

5.26 HEATED AIR CURLING IRON (or BRUSH) – A curling iron (or brush) in which a fan included in the appliance blows air over the heating elements and out through openings in the barrel of the appliance.

5.27 HIGH-VOLTAGE CIRCUIT – A circuit involving a potential of more than 600 volts.

5.28 INPUT VOLTAGE SELECTOR – The means provided on an appliance to adjust for the available input voltage.

5.29 LIMIT CONTROL – As applicable to hand-supported hair dryers, a limit control, as shown in item A of [Figure 5.2](#), is a non-resettable control (a control intended to operate only once) that operates to open all electrical circuits to reduce the risk of fire or electric shock.

Figure 5.2
Typical hair dryer circuit

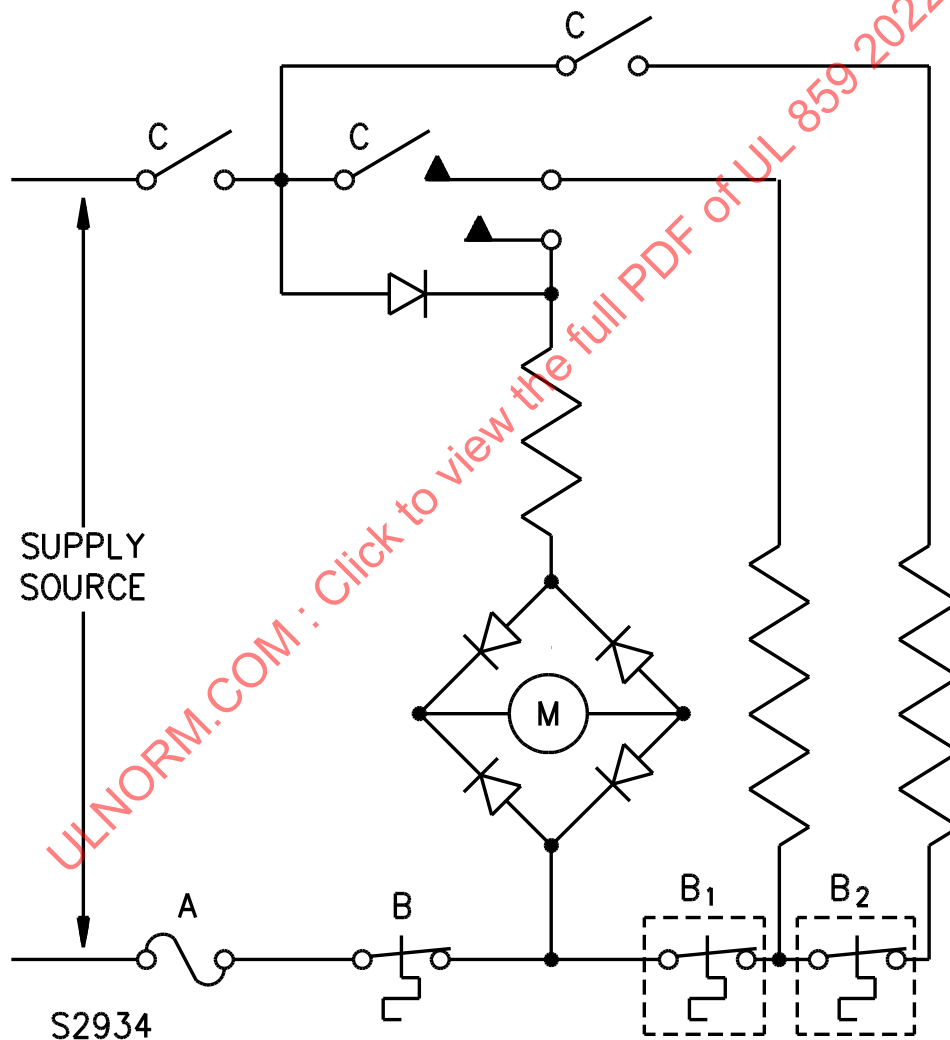

A – Limit control (a non-resettable device, as defined in [5.28](#)).

B – Temperature control (a calibrated automatic-reset device, as defined in [5.36](#)).

B₁, B₂ – Temperature control shown at two other locations.

C – Switches.

M – Motor.

5.30 LIMITED ENERGY PRIMARY CIRCUIT – A line voltage circuit that incorporates a limiting impedance in series with the supply circuit so that:

- a) The circuit potential on the load side of the limiting impedance does not exceed 42.4 volts peak (30 volts rms) under intended conditions; and
- b) The maximum energy available at the load side of the limiting impedance circuit is 100 volt-amperes under any condition, including abnormal operation.

5.31 LINE VOLTAGE CIRCUIT – A circuit involving a potential of not more than 250 volts and having circuit characteristics in excess of those of a low-voltage circuit or a limited primary energy circuit.

5.32 LOW-VOLTAGE CIRCUIT – A circuit supplied by a primary battery, by a Class 2 transformer, or by a combination of a transformer and fixed impedance that, as a unit, complies with all performance requirements for Class 2 transformers and that does not involve an open circuit potential of more than 42.4 volts peak (30 volts rms).

5.33 PORTABLE APPLIANCE – An appliance capable of being carried or conveyed.

5.34 PREHEAT CYCLE – A cycle of operation, intended for rapid heating, in which the heating element operates at an initial higher level of energy for a period of time. The energy level then declines to a lower normal use temperature-maintenance level. It may fluctuate between the high and low levels during a use of the appliance. The energy level may be controlled by varying the amount of wattage, the duration or duty cycle, or a combination thereof. The change in the energy level may be initiated by a timer, a temperature controller, or a combination of the two. Appliances having a preheat cycle of operation are commonly known as "Instant Heat" type. The temperature transient condition associated with the operation of a positive temperature coefficient (PTC) heating element or a thermostat is not considered to be a preheat cycle.

The following are some examples of preheat type appliances:

- a) The appliance operates at the higher preheat wattage level for a length of time determined by a timing device or circuit. The wattage then drops to a constant lower temperature-maintenance level for the remainder of operation.
- b) The appliance operates at a higher preheat wattage level initially for varying lengths of time depending upon temperature. The wattage varies with time in response to the temperature controller to maintain normal operating temperature.
- c) The appliance operates at a fixed wattage level for a predetermined length of time. Then the same amount of wattage is applied on a pre-programmed duty cycle by means of a switching mechanism to maintain normal operating temperature.
- d) The appliance operates at a fixed wattage level for a predetermined length of time. Then the same amount of wattage is applied on a duty cycle that adjusts depending upon temperature by means of a switching mechanism and a temperature controller.

5.35 STATIONARY APPLIANCE – A cord-connected appliance intended to be fastened in place or located in a dedicated space.

5.36 TEMPERATURE CONTROL – As applicable to hand-supported hair dryers, a temperature control, as shown in item B of [Figure 5.2](#), is an automatic-reset temperature-sensing control that opens an electrical circuit to limit temperatures during Abnormal Operation Tests described in Section [46](#) and/or Normal Temperature test (except no fabric condition) described in [44.5.3](#). A temperature control is calibrated and endurance tested for at least 6,000 cycles of operation and complies with all other requirements in the Standard for Limit Controls, UL 353, or the Standard for Temperature-Indicating and

-Regulating Equipment, UL 873. Compliance with the Standard for Automatic Electrical Controls for Household and Similar Use, Part 1: General Requirements, UL 60730-1, and/or the applicable Part 2 standard from the UL 60730 series fulfills the UL 873 requirements. See [24.2.1](#) – [24.2.2](#).

5.37 TEMPERATURE-REGULATING CONTROL – A control that functions only to regulate the temperature under conditions of intended use.

5.38 THERMAL CUT-OFF – A temperature- or temperature- and current-sensitive device that is replaceable but not resettable. It is intended to reduce the risk of fire, electric shock, or injury to persons due to overheating of an appliance during abnormal operation.

5.39 WALL-HUNG APPLIANCE – A cord-connected appliance that is provided with keyhole slots, hanger holes, similar feature for hanging on a wall during the performance of its intended function. A wall-hung appliance may consist of two interconnected units where one is intended to hang on a wall and the other is intended to be supported by hand during use. Reference is to be made to the user manual of the appliance in establishing the intended functions of the appliance.

5.40 WAX DEPILATORY APPLIANCE – An appliance intended for melting a wax-like material (hereafter referred to as wax) that is first applied to and then stripped from the body for the purpose of removing unwanted hair.

CONSTRUCTION

6 General

6.1 In the following text, a requirement that applies only to a specific type or types of appliances, such as a hand-supported hair dryer and a curling iron, is so identified by specific reference in that requirement to the type or types involved. Absence of such specific reference or use of the term "appliance" indicates that the requirement applies to all appliances covered by this standard.

6.2 An appliance that is a combination of two or more types (for example, an appliance having a hand-supported part and a counter-supported part), or an appliance that fits the definition of two or more types (for example, an appliance that can be used while supported by hand or while supported by a counter top), is to be investigated in accordance with the applicable requirements for the types of appliances involved. If two requirements that address the same condition differ, the appliance is to be investigated to the more severe requirement.

6.3 A heated air curling iron or brush, as defined in [5.25](#), shall comply with the requirements applicable to hand-supported hair dryers and curling irons.

6.4 A container for liquid intended for use with the appliance, and supplied as part of the appliance, shall comply with applicable construction requirements.

6.5 A curling iron that is likely to be laid on combustible material shall be provided with a stand made of material resistant to combustion upon which it may be placed when not in use.

Exception: A stand need not be provided if the temperature attained by the appliance is not sufficiently high to cause the ignition of the combustible material.

6.6 A curling iron that attains a temperature higher than 100°C (212°F) when operated continuously shall be provided with an integral stand. A stand provided for other types of appliances may be a separate device or integral with the appliance.

6.7 With respect to [6.6](#), an integral stand provided for a curling iron shall be of such design or shape that any surface of the curling iron exceeding 150°C (302°F) will not contact the supporting surface when the curling iron is supported in its intended manner by the stand.

6.8 A polymeric material used as an integral stand in compliance with the requirements in [6.7](#) shall be rated for the temperature it is subjected to during use.

7 Hair Dryer Immersion Protection

7.1 A hand-supported hair-drying appliance specified in [5.25A](#) shall be constructed to reduce the risk of electric shock when the appliance is energized, with its power switch in either the "on" or "off" position, and immersed in water having an electrically conductive path to ground.

7.2 Compliance with [7.1](#) may be accomplished with the use of an:

- a) Integral ground-fault circuit-interrupter (GFCI),
- b) Appliance leakage-current interrupter (ALCI), or
- c) Integral protective device of another type that de-energizes all current-carrying parts (hereafter referred to as a protective device) when the hand-supported hair-drying appliance is immersed in water having an electrically conductive path to ground.

7.3 If a hand-supported hair-drying appliance is provided with a GFCI, the GFCI shall comply with the requirements for Class A cord-connected GFCIs in the Standard for Ground-Fault Circuit-Interrupters, UL 943.

Exception: A GFCI located in the wall unit of a wall-mounted permanently-connected hair dryer shall comply with the requirements for Class A permanently-connected GFCIs in UL 943.

7.4 If a hand-supported hair-drying appliance is provided with a protective device other than a GFCI, the protective device shall be investigated and determined to be acceptable for the application. Investigation of the protective device shall include, but need not be limited to, consideration of:

- a) Electrical rating,
- b) Operating temperatures,
- c) Reliability of operation,
- d) Resistance to the effects of abnormal operating conditions,
- e) Resistance to mechanical abuse,
- f) Resistance to electrical transients, and
- g) Resistance to moisture.

The combination of hair-drying appliance and protective device shall comply with the test described in the Immersion-Protection Trip Time Measurement Test, Section [40](#).

Exception No. 1: A protective device is deemed acceptable for the application if it complies with the requirements for Class A cord-connected GFCIs in the Standard for Ground-Fault Circuit-Interrupters, UL 943, except that it is not required to:

- a) Have a grounding conductor;

- b) Have the same type of power supply cord;
- c) Comply with the high-resistance ground faults test under the condition that any power conductor is open-circuited; or
- d) Provide grounded neutral protection by compliance with the high-resistance ground faults test, under the test condition that the neutral conductor is grounded at a point in the load circuit.

Exception No. 2: A protective device is deemed acceptable for the application if it complies with the requirements in the Standard for Appliance Leakage-Current Interrupters, UL 943B.

The combination of a hand-supported hair-drying appliance and such a protective device is not required to be subjected to the test described in the Conductive Coating Test, Section [35](#).

7.5 A GFCI or other protective device shall be integral with the plug of the hand-supported hair-drying appliance power supply cord.

Exception No. 1: For a wall-mounted permanently-connected hair dryer, the GFCI or other protective device may be located in the wall unit.

Exception No. 2: A GFCI or other protective device may be located in the wall hung unit of hair dryer enclosure, after additional investigations with regard to acceptability after immersion, resistance to mechanical abuse, and similar considerations.

7.6 A user-resettable protective device shall incorporate a supervisory circuit as described in the Standard for Ground-Fault Circuit-Interrupters, UL 943, for GFCIs. See [7.8](#).

Exception: A user-resettable protective device may be provided with a reset feature not having a test function based on all of the following:

- a) *The protective device complies with the Standard for Tests for Safety-Related Controls Employing Solid-State Devices, UL 991. If the computational investigation is conducted, the maximum predicted failure rate (λ_p) shall not exceed 1.5 failures per million hours predicted. If the demonstrated method is conducted, the test acceleration multiplier shall be 5763.*
- b) *The instructions provided with the appliance alert the user to the reset feature and how and when to use it.*
- c) *The instructions provided with the appliance alert the user to not reset and reuse the appliance should the protective device trip as a result of immersion.*

7.7 A switch included for testing a user resettable protective device shall be permanently marked "Test" and "Reset" on or adjacent to the switch actuators.

7.8 After a protective device de-energizes current-carrying parts, it shall not automatically reset. Hand supported hair-drying appliances shall have a user resettable protective device.

7.9 A protective device that is integral with the attachment plug of a hand-supported hair-drying appliance may be provided with a single outlet convenience receptacle when all of the following requirements are met:

- a) The convenience receptacle is:
 - 1) Of the same configuration as the attachment plug,

- 2) Wired on the load side of the protective device, and
 - 3) Wired so that the same polarization as the attachment plug is maintained.
- b) The convenience receptacle has a rating of 15 amperes, 125 volts and complies with the Standard for Attachment Plugs and Receptacles, UL 498.
 - c) The face of a convenience receptacle that is less than 5/8 inch (15.9 mm) wide or 7/8 inch (22.2 mm) long complies with the mounting clearance requirements specified in [22.8](#).
 - d) The area surrounding the convenience receptacle is free of any projections that might interfere with full insertion of the blades of an attachment plug having a face size as specified in [Figure 7.1](#).
 - e) When an attachment plug, as shown in [Figure 7.1](#), is fully inserted into the convenience receptacle, the test and reset buttons of a user-resettable protective device are accessible for testing and resetting the protective device without the use of a tool.
 - f) The protective device complies with the requirements for cord-connected GFCIs specified in the Standard for Ground-Fault Circuit-Interrupters, UL 943.

Exception No. 1: Flexible cord acceptable for use with hand-supported hair dryers as specified in [Table 13.2](#) may be used.

Exception No. 2: Means for grounding need not be provided.

- g) The convenience receptacle contact slots and grounding hole, if any, are located so that the line blades of a grounding-type plug cannot be mated by deliberate manual force, including manipulation, to deflect the grounding pin to the outside of the body of the protective device. An obstruction provided to comply with this requirement is to have minimum size and shape indicated by the shaded area in [Figure 7.2](#). The obstructions are to be coplanar with the face or recessed by no more than 3/32 inch (2.4 mm). Constructions having rigid bodies, which are materials having a minimum hardness of 90 when measured on the "A" scale of a Shore Durometer, may have the indicated "A" dimensions reduced to 0.531 inch (13.5 mm).
- h) The hair dryer immersion protective device complies with the abnormal operation test described in [46.10.1](#) – [46.10.5](#).
- i) A permanent and legible marking is provided near the convenience receptacle to:
 - 1) Specify the maximum current and wattage rating of an appliance intended to be plugged into the convenience receptacle as specified in [72.1.7](#),
 - 2) Indicate that the appliance is to be unplugged immediately after use as specified in [72.10.1](#), and
 - 3) Indicate that a direct plug-in (cordless) appliance is not to be used as specified in [72.10.1](#).
- j) The instruction manual includes the operating instructions specified in [76.10](#).

Figure 7.1

Plug-face dimensions for determining acceptable convenience receptacle insertion clearance

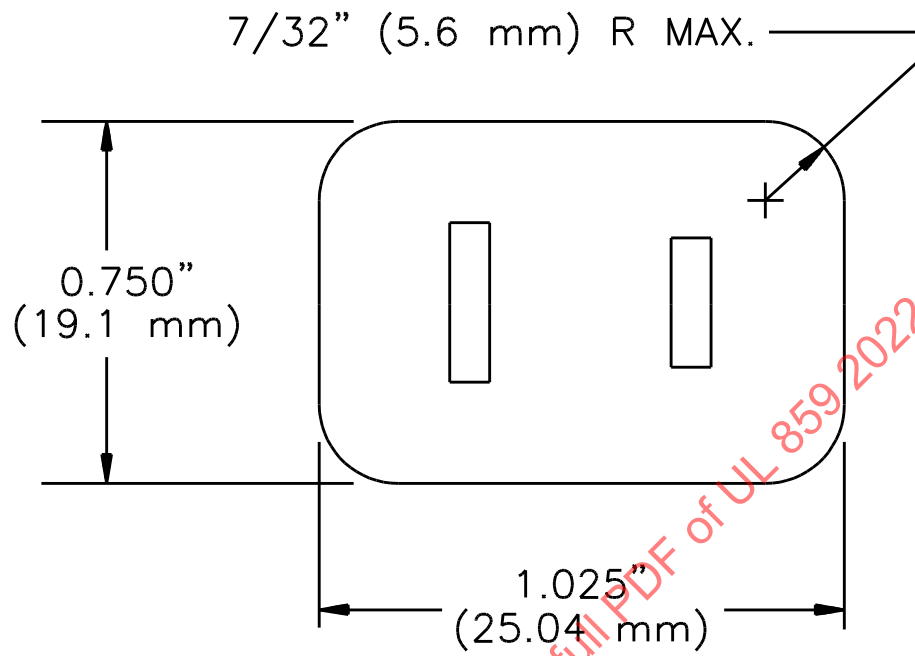

S3867

BLADES CENTERED

ULNORM.COM : Click to view the full PDF of UL 859 2022

Figure 7.2

Face of a 15-ampere, 125-volt convenience receptacle showing the smallest acceptable obstruction (shown shaded) for the grounding pin on the mating plug

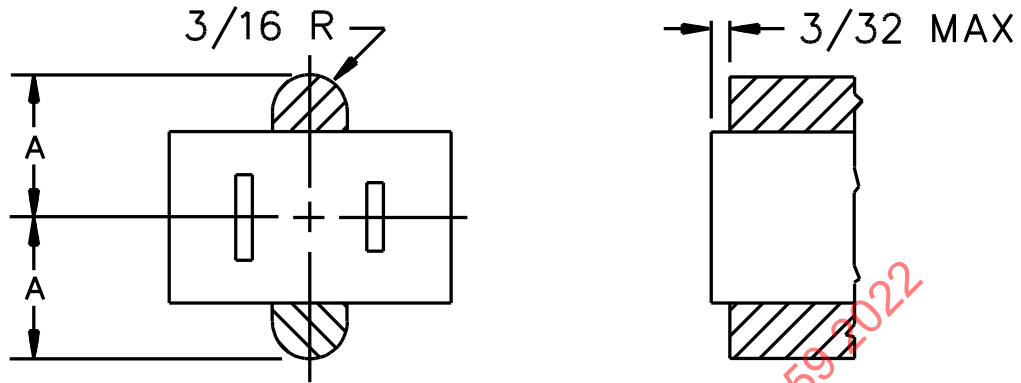

Obstruction for a 2-Pole, 2-Wire (Nongrounding) Receptacle

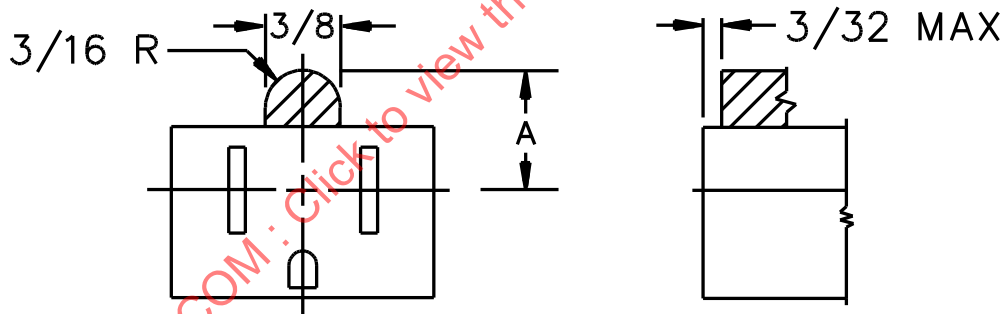

Obstruction for a 2-Pole, 3-Wire (Grounding) Receptacle

Inch	3/32	3/16
mm	2.4	4.8

Dimension A		Shore Durometer Hardness (Scale A)
Inch	mm	
0.625	15.9	less than 90
0.531	13.5	90 or more

7.10 With regard to 7.9(f), each output circuit shall be considered if one is not representative of the other. For example, the short circuit test shall be conducted with each output short-circuited one at a time. The dielectric voltage-withstand test between line-connected circuits and load circuits shall include both load circuits. The temperature test shall be conducted with:

- a) The hair dryer load circuit and the convenience receptacle each loaded to rated value and
- b) The convenience receptacle loaded to 15 amperes with no load connected to the hair dryer load circuit.

8 Frame and Enclosure

8.1 General

8.1.1 The frame and enclosure of an appliance shall be sufficiently strong and rigid to resist the abuses likely to be encountered during service. The degree of resistance inherent in the appliance shall preclude total or partial collapse with the attendant reduction of spacings, loosening or displacement of parts, and other conditions which alone or in combination constitute an increase in the risk of fire, electric shock, or injury to persons.

8.1.2 Among the factors taken into consideration in evaluating an enclosure for acceptability are its:

- a) Physical strength,
- b) Resistance to impact,
- c) Moisture absorptive properties,
- d) Combustibility,
- e) Resistance to corrosion, and
- f) Resistance to distortion at temperatures to which the enclosure may be subjected under conditions of normal or abnormal use.

For a nonmetallic enclosure, all these factors are to be considered with respect to thermal aging.

8.2 Polymeric enclosures and parts

8.2.1 A polymeric enclosure shall comply with the Standard for Polymeric Materials – Use in Electrical Equipment Evaluations, UL 746C.

Exception: The Abnormal Operation Tests, Section 46, shall be applied in lieu of the abnormal and severe conditions requirements specified in UL 746C. For the polymeric enclosure of an appliance other than a hand-supported hair dryer, the use of HB material may require additional abnormal or severe conditions tests.

8.3 Metal enclosures

8.3.1 The minimum thickness of a metal enclosure shall be as indicated in [Table 8.1](#).

Table 8.1
Minimum thickness of enclosure metal

Metal	Thickness at small, flat, unreinforced surfaces and at surfaces that are reinforced by curving, ribbing, and the like (or are otherwise of a shape or size) to ensure adequate physical strength,		Thickness at surfaces to which a wiring system is to be connected in the field,		Thickness at relatively large unreinforced flat surfaces,	
	inch	(mm)	inch	(mm)	inch	(mm)
Die-cast	3/64	(1.2)	–	–	5/64	(2.0)
Cast malleable iron	1/16	(1.6)	–	–	3/32	(2.4)
Other cast metal	3/32	(2.4)	–	–	1/8	(3.2)
Uncoated sheet steel	0.026 ^a	(0.66)	0.032	(0.81)	0.026	(0.66)
Galvanized sheet steel	0.029 ^a	(0.74)	0.034	(0.86)	0.029	(0.74)
Nonferrous sheet metal	0.036 ^a	(0.91)	0.045	(1.14)	0.036	(0.91)

^a Thinner sheet metal may be used if determined to be acceptable when the enclosure is evaluated under considerations such as those specified in [8.1.2](#).

8.4 Corrosion resistance

8.4.1 Iron and steel parts shall be made corrosion resistant by painting, galvanizing, plating, or other equivalent means if the malfunction of such unprotected parts would result in a risk of fire, electric shock, or injury to persons.

Exception No. 1: In constructions in which the oxidation of iron or steel due to the exposure of the metal to air and moisture will not be appreciable – thickness of metal and temperature also being factors – surfaces of sheet steel and cast-iron parts within an enclosure not required to be made corrosion resistant.

Exception No. 2: Bearings, lamination, or minor parts of iron or steel, such as washers, screws, and similar parts are not required to be made corrosion resistant.

8.4.2 A container for liquid shall be made resistant to the possible corrosive effect of the liquid intended to be used in the container.

8.5 Accessibility of live parts

8.5.1 An electrical part of an appliance shall be located or enclosed so that unintentional contact with any uninsulated live part and internal wiring will be prevented.

8.5.2 A part of the outer enclosure that is capable of being opened or removed by the user without using a tool (to attach an accessory, to make an operating adjustment, to replace a fuse, or for other reasons) is to be opened or removed when determining compliance with [8.5.1](#).

8.5.3 The enclosure of an appliance shall have no opening that permits a probe, as illustrated in [Figure 8.1](#), to touch any part that involves a risk of electric shock.

Figure 8.1
Articulate probe with web stop

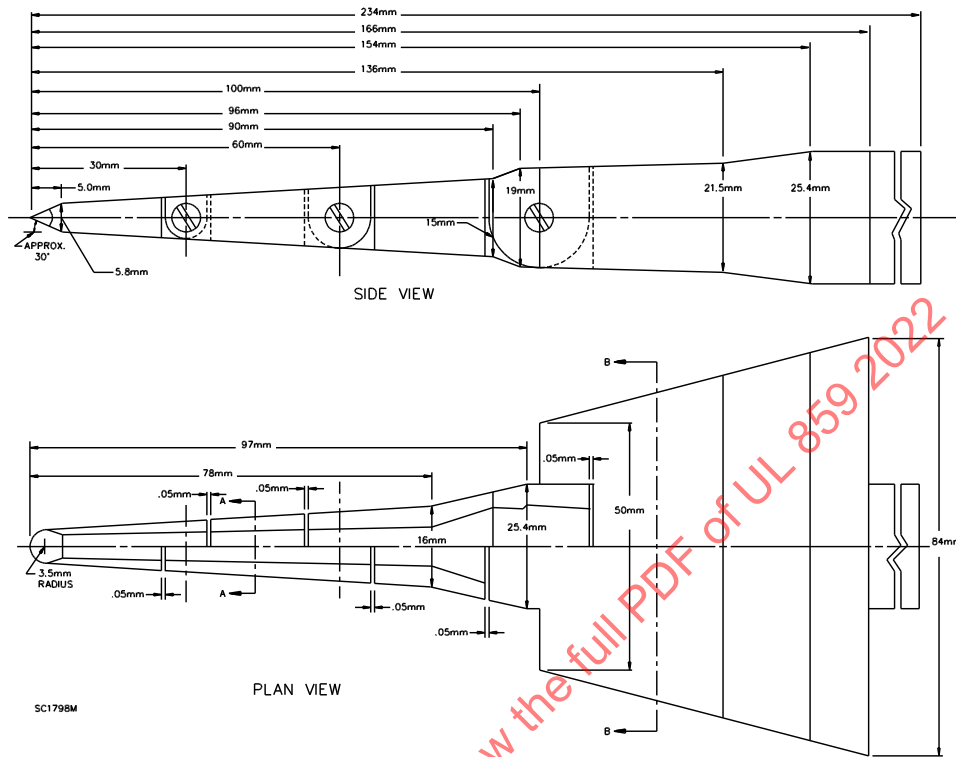
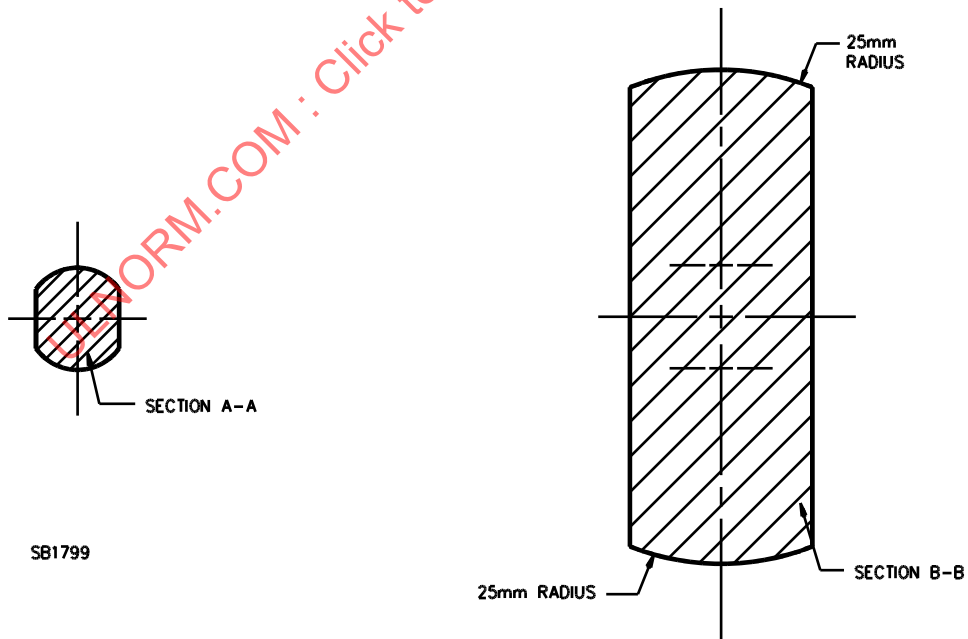
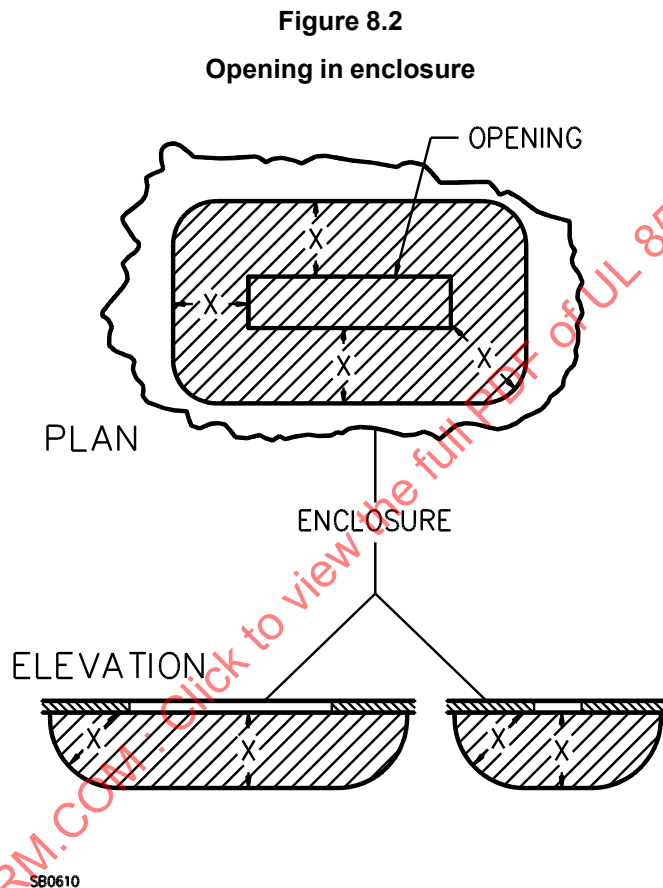

Figure 8.1 (Cont'd)



8.5.4 With regard to 8.5.3, the probe is to be articulated into any configuration and rotated or angled to any position before, during, or after insertion into the opening. The penetration shall be to any depth allowed by the opening size, including minimal depth combined with maximum articulation. The probe shall be applied with the minimum force required to determine accessibility and not as an instrument to evaluate the strength of a material.

8.5.5 An opening that will permit entrance of a 1-inch (25.4-mm) diameter rod is permitted when it complies with the conditions shown in Figure 8.2.



NOTE – The opening is acceptable if, within the enclosure, there is no uninsulated live part or film-coated wire:

- a) Less than X distance from the perimeter of the opening, as well as
- b) Within the volume generated by projecting the perimeter X distance normal to its plane.

X equals five times the diameter of the largest diameter rod that can be inserted through the opening, but not less than 6-1/16 inches (154 mm).

8.5.6 A live part of a limited-energy circuit in [5.30](#) requires the same degree of protection against unintentional contact as a live part of a line voltage circuit.

8.5.7 Insulated brush caps do not require additional enclosure.

8.5.8 An area of an enclosure that is provided with a group of openings or with a guarded opening (such as a grille, louver, or screen) is to be subjected to the strength of enclosure test described in [35.1](#).

8.5.9 The enclosure of a remotely or automatically controlled appliance shall reduce the risk of molten metal, burning insulation, or flaming particles, from falling on combustible materials, including the surface upon which the appliance is supported.

8.5.10 The requirement in [8.5.9](#) will necessitate the use of a barrier of material that is resistant to combustion:

a) Under a motor unless:

1) The structural parts of the motor or of the appliance provide the equivalent of such a barrier;

2) The protection provided with the motor is such that no burning insulation or molten material falls to the surface that supports the appliance when the motor is energized under each of the following fault conditions:

i) Main winding opened;

ii) Starting winding opened;

iii) Starting switch short-circuited; and

iv) For a permanent split capacitor motor, the capacitor short-circuited (the short circuit is to be applied before the motor is energized, and the rotor is to be locked);

or

3) The motor is provided with a thermal motor protector (a protective device that is sensitive to temperature and current) that will prevent the temperature of the motor windings from exceeding 125°C (257°F) under the maximum load under which the motor will run without causing the protector to cycle, and from exceeding 150°C (302°F) with the rotor of the motor locked.

b) Under wiring, unless the wiring is provided with flame-retardant rating VW-1 (FR-1), or wiring contained within sleeving rated VW-1, or the equivalent.

8.5.11 The requirement in [8.5.9](#) will also necessitate that a switch, relay, solenoid, or the similar part be individually and completely enclosed unless there is no opening in the bottom of the appliance enclosure, or it can be shown that malfunction of the component would not result in a risk of fire.

Exception: Terminals of a switch, relay, solenoid, or the like are not required to be individually and completely enclosed.

8.5.12 The barrier specified in [8.5.10](#) shall be horizontal, shall be located as indicated in [Figure 8.3](#), and shall have an area no less than that described in [Figure 8.3](#). An opening such as for drainage or ventilation, is permitted in the barrier if such an opening would not permit molten metal, burning insulation, or flaming particles to fall on combustible material.

Figure 8.3
Location and extent of barrier

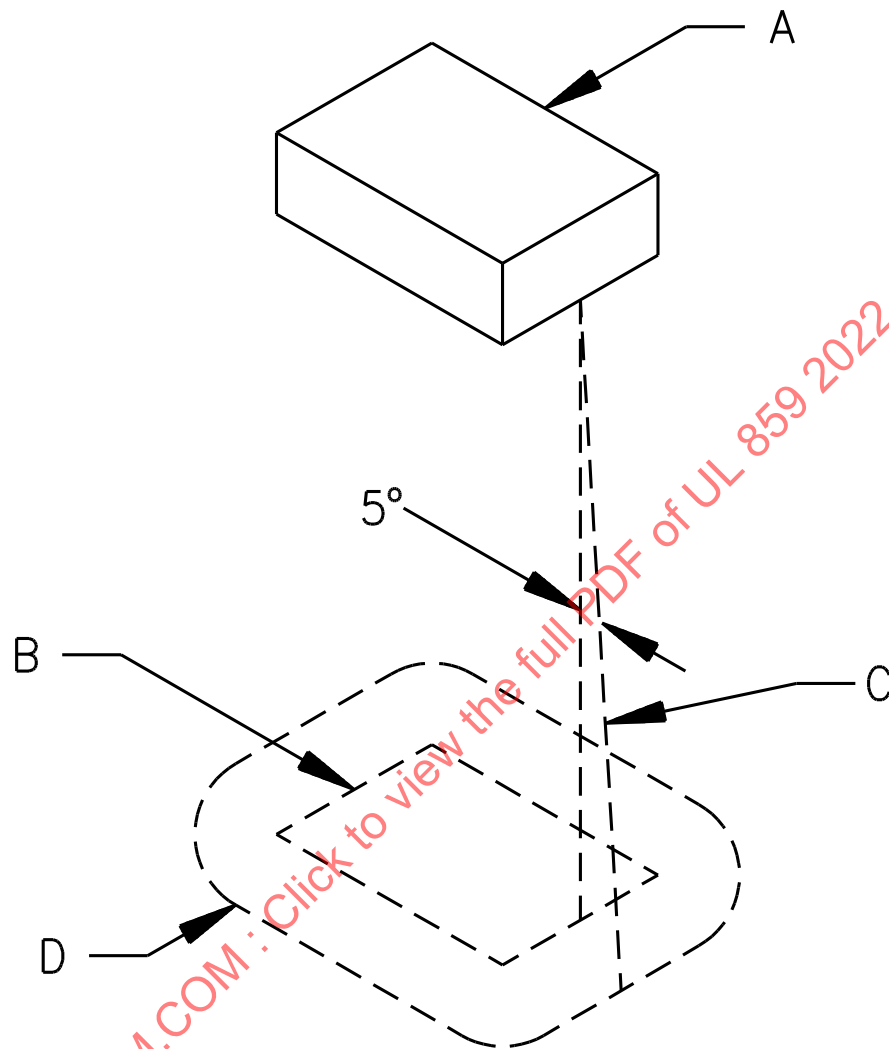

SA0604-1

A – Region to be shielded by barrier. This will consist of the entire component if it is not otherwise shielded, and will consist of the unshielded portion of a component which is partially shielded by the component enclosure or equivalent.

B – Projection of outline of component on horizontal plane.

C – Inclined line which traces out minimum area of barrier. When moving, the line is always:

- 1) Tangent to the component,
- 2) 5 degrees from the vertical, and
- 3) Oriented so that the area traced out on a horizontal plane is maximum.

D – Location (horizontal) and minimum area for barrier. The area is that included inside the line of intersection traced out by the inclined line C and the horizontal plane of the barrier.

8.6 Doors and covers

8.6.1 The door or cover of an enclosure shall be provided with means for holding it in the closed position.

8.6.2 The door or cover of an enclosure shall be hinged (or similarly attached) if it gives access to any overload protective device, the functioning of which requires renewal, or if it is necessary to open the cover in connection with the operation of the protective device. Such a door or cover shall be provided with a latch or similar device and shall be tight-fitting or shall overlap the surface of the enclosure around the opening.

9 Reduction of Risk of Injury to Persons

9.1 General

9.1.1 Materials that are relied upon to reduce the risk of injury to persons shall have such properties as to meet the demand of intended loading conditions.

9.1.2 Asbestos shall not be used.

9.1.3 A moving part that can result in a risk of injury to persons shall be enclosed or provided with other means to reduce unintentional contact.

9.1.4 With respect to the requirement specified in [9.1.3](#), the construction and intended use of the appliance are to be considered in investigating a guard or enclosure. Among the factors to be evaluated in evaluating the acceptability of an exposed moving part are:

- a) The degree of exposure;
- b) The sharpness of the moving part; and
- c) The possibility of fingers, arms, hair, or clothing being drawn into the moving part (such as at points where gears mesh, where belts travel onto a pulley, or where moving parts close in a pinching or shearing action).

9.1.5 An appliance, or any item furnished with an appliance, shall have no sharp edge, burr, point, or spike inside or outside the appliance that results in injury to persons during intended use and maintenance.

9.1.6 On an appliance adjustable for height, means shall be provided for holding the upper parts securely in position. Means shall also be provided to prevent the upper part from descending rapidly if the securing means loosens or fails to operate as intended.

9.1.7 A hand-supported hair dryer shall have each air intake opening provided with a screen or equivalent means so that there are no openings larger than 0.004 square inch (0.03 cm²).

9.2 Appliances with reservoirs

9.2.1 An appliance in which liquid reaches a temperature greater than 46°C (114.8°F) shall comply with the requirements specified in [9.2.2](#) – [9.2.4](#), [36.1](#) – [36.3](#), and [37.2](#).

Exception No. 1: An electrode-type appliance is not required to comply with these requirements. For requirements for an electrode-type appliance, see Sections [78](#) – [84](#).

Exception No. 2: A wax depilatory appliance is not required to comply with the requirements specified in [9.2.3](#), [9.2.4](#), and [36.1](#) – [36.3](#).

9.2.2 The construction of the appliance shall reduce the risk of injury to persons under conditions of intended use. Openings through which liquid can be emitted shall not be provided unless such openings are needed to perform an operating function.

9.2.3 An appliance with a vessel or container with a capacity of more than 32 fluid ounces (946 mL) shall be provided with a fully inserting or a lock-on lid.

9.2.4 If any part of an appliance requires assembly (for example, engagement of a twist-lock part), then improper assembly that results in a risk of injury to persons shall be clearly visible to the user.

9.3 Wax depilatory appliances

9.3.1 The maximum temperature of the wax, measured as described in [44.2.1](#) – [44.2.3](#), shall not exceed 75°C (167°F).

9.3.2 The maximum temperature rise of surfaces that may be contacted by the user shall be as specified in [Table 44.2](#).

9.3.3 When there are multiple heat settings (for example, a setting for maintaining molten wax at the intended temperature for application to all of the skin and a higher heat setting for quick melting of solid wax), the appliance shall comply with all of the following:

a) If the wax is capable of being heated above 75°C (167°F) for quick melting, the reservoir in which the wax is so heated shall be provided with a nonremovable, self-closing lid or cover.

b) A visible overhear condition indicator shall be provided. Such an indicator shall indicate when the wax temperature exceeds 75°C. This indicator shall be separate and independent of any other temperature indicator (for example, an indicator light whose functioning depends upon the setting of an adjustable thermostat) which may be provided. See [44.2.3](#), [74.7\(l\)\(13\)](#), and [76.8\(e\)](#).

c) A marking (such as a number or symbol) shall be provided adjacent to each heat selector position. A permanent marking shall be provided on the appliance in accordance with [72.8.1\(b\)](#), and the Use and Care Instructions shall warn the user against applying wax that has been heated at a setting higher than the intended setting [see [74.7\(l\)\(13\)](#)].

d) A part of a temperature control that is user-operated (an adjustment knob or similar part) shall be constructed so that deliberate and positive action by the operator is required to select a heat setting or to change from one heat setting to another. A construction that requires two separate and distinct motions by the user (such as push and turn) is an example of a control that complies with this requirement.

9.3.4 With reference to [9.3.3\(a\)](#), a nonremovable cover is one which requires special tools (tools not available to other than service personnel) for removal. A self-closing cover is a cover that returns to its fully closed position without any action on the part of the user other than releasing it from any opened position while the appliance is supported by a flat, horizontal surface.

9.3.5 In accordance with [46.9.5](#) and [76.8](#), if the malfunction of a temperature-regulating control increases the application temperature of the wax above 75°C (167°F), visible means, such as an indicator light, shall be provided to inform the user of an overhear condition.

Exception: A visible overhear condition indicator is not required if a thermal cutoff or a trip-free manual-reset thermostat operates upon short-circuiting of the temperature-regulating control. The temperatures