



# UL 727

## STANDARD FOR SAFETY

### Oil-Fired Central Furnaces

ULNORM.COM : Click to view the full PDF of UL 727 2024

[ULNORM.COM](https://ULNORM.COM) : Click to view the full PDF of UL 727 2024

UL Standard for Safety for Oil-Fired Central Furnaces, UL 727

Tenth Edition, Dated January 31, 2018

### **Summary of Topics**

***This revision of UL 727 dated May 20, 2024 adds B100 biodiesel fuel requirements: [1.2](#), [3.6A](#), [3.20](#), [3.20A](#), [37.8](#), Section [42A](#) and [60.1](#).***

Text that has been changed in any manner or impacted by ULSE's electronic publishing system is marked with a vertical line in the margin.

The new and revised requirements are substantially in accordance with Proposal(s) on this subject dated January 29, 2024.

All rights reserved. No part of this publication may be reproduced, stored in a retrieval system, or transmitted in any form by any means, electronic, mechanical photocopying, recording, or otherwise without prior permission of ULSE Inc. (ULSE).

ULSE provides this Standard "as is" without warranty of any kind, either expressed or implied, including but not limited to, the implied warranties of merchantability or fitness for any purpose.

In no event will ULSE be liable for any special, incidental, consequential, indirect or similar damages, including loss of profits, lost savings, loss of data, or any other damages arising out of the use of or the inability to use this Standard, even if ULSE or an authorized ULSE representative has been advised of the possibility of such damage. In no event shall ULSE's liability for any damage ever exceed the price paid for this Standard, regardless of the form of the claim.

Users of the electronic versions of UL's Standards for Safety agree to defend, indemnify, and hold ULSE harmless from and against any loss, expense, liability, damage, claim, or judgment (including reasonable attorney's fees) resulting from any error or deviation introduced while purchaser is storing an electronic Standard on the purchaser's computer system.

No Text on This Page

[ULNORM.COM](https://ULNORM.COM) : Click to view the full PDF of UL 727 2024

**JANUARY 31, 2018**  
(Title Page Reprinted: May 20, 2024)

1

**UL 727**

**Standard for Oil-Fired Central Furnaces**

First Edition – March, 1955  
Second Edition – October, 1957  
Third Edition – August, 1961  
Fourth Edition – August, 1972  
Fifth Edition – June, 1973  
Sixth Edition – July, 1980  
Seventh Edition – November, 1986  
Eighth Edition – August, 1994  
Ninth Edition – April, 2006

**Tenth Edition**

**January 31, 2018**

This UL Standard for Safety consists of the Tenth edition including revisions through May 20, 2024.

The Department of Defense (DoD) has adopted UL 727 on June 17, 1994. The publication of revised pages or a new edition of this Standard will not invalidate the DoD adoption.

Comments or proposals for revisions on any part of the Standard may be submitted to ULSE at any time. Proposals should be submitted via a Proposal Request in the Collaborative Standards Development System (CSDS) at <https://csds.ul.com>.

Our Standards for Safety are copyrighted by ULSE Inc. Neither a printed nor electronic copy of a Standard should be altered in any way. All of our Standards and all copyrights, ownerships, and rights regarding those Standards shall remain the sole and exclusive property of ULSE Inc.

**COPYRIGHT © 2024 ULSE INC.**

No Text on This Page

[ULNORM.COM](https://ULNORM.COM) : Click to view the full PDF of UL 727 2024

## CONTENTS

### PART 1 – ALL PRODUCTS

#### INTRODUCTION

1	Scope .....	7
2	Units of Measurement .....	7
3	Glossary .....	7
4	Components .....	11

#### CONSTRUCTION – MECHANICAL

5	Assembly .....	12
6	Servicing .....	14
	6.1 General .....	14
	6.2 Moving parts .....	14
7	Disposal of Combustion Products .....	15
8	Base .....	15
9	Casings .....	17
10	Radiation Shields or Liners .....	18
11	Materials in Air Handling Compartments .....	18
12	Air Filters .....	19
13	Combustion Chambers .....	19
14	Radiators .....	19
15	Heating Surface Joints .....	19
16	Baffles .....	20
17	Flue Collars .....	20
18	Dampers and Draft Regulators .....	21

#### CONSTRUCTION – ELECTRICAL

19	Controls .....	21
	19.1 Application .....	21
	19.2 Limit control .....	21
	19.3 Fan control .....	22
20	Field Wiring .....	22
	20.1 General .....	22
	20.2 Leads and terminals .....	24
21	Internal Wiring .....	25
	21.1 General .....	25
	21.2 Methods .....	26
	21.3 Short circuit protection .....	29
22	Separation of Circuits .....	29
23	Bonding for Grounding .....	30
24	Servicing and Adjustment .....	33
25	Electrical Components .....	34
26	Mounting of Electrical Components .....	34
27	Electrical Enclosures .....	34
	27.1 General .....	34
	27.2 Doors and covers .....	42
	27.3 Field wiring system connections .....	43
28	Motors and Motor Overload Protection .....	44

29	Overcurrent Protection of High-Voltage Control-Circuit Conductors .....	48
29.1	General.....	48
29.2	Direct-connected high-voltage control circuit.....	48
29.3	Tapped high-voltage control circuits .....	48
29.4	Overcurrent-protective devices .....	49
30	Overcurrent Protection of Transformers .....	49
30.1	High-voltage transformers .....	49
30.2	Low-voltage transformers .....	50
31	Switches and Controllers .....	51
32	Capacitors .....	52
33	Electrical Insulating Material.....	52
34	Spacings – High-Voltage Circuit .....	52
35	Spacings – Low-Voltage Circuits.....	54
36	Accessibility of Uninsulated Live Parts .....	54

## PERFORMANCE

37	General .....	55
38	Test Installation for Standard Clearances .....	57
38.1	Downflow and upflow furnaces (for installation in other than closets or alcoves).....	57
38.2	Horizontal furnace .....	63
39	Test Installation for Alcove or Closet .....	66
39.1	Downflow, upflow, and horizontal furnaces.....	66
39.2	Air outlet and inlet .....	74
40	Instrumentation .....	75
40.1	Draft .....	75
40.2	Fuel input.....	75
40.3	Power measurement.....	75
40.4	Speed measurement.....	75
40.5	Static pressure .....	75
40.6	Temperature measurement.....	77
41	Initial Test Conditions.....	79
41.1	General.....	79
41.2	Furnace equipped with mechanical atomizing burner.....	80
41.3	Furnace equipped with vaporizing burner .....	80
41.4	Static pressures for tests .....	81
42	Combustion Test – Burner and Furnace .....	81
42A	Range of Fuels Test – Burner and Furnace .....	81
43	Operation Tests.....	82
44	Limit Control Cutout Test.....	82
45	Continuity of Operation Test .....	83
46	Airflow, Downflow or Horizontal Furnace Test .....	83
47	Temperature Tests.....	84
47.1	General.....	84
48	Continuous Operation Test.....	87
49	Blocked Inlet Test .....	88
50	Fan Failure Test .....	88
51	Stalled Fan Motor Test.....	89
52	Blocked Outlet Test .....	90
53	Short-Circuit Test.....	90
54	Overload Test, High-Voltage Transformers .....	93
55	Burnout Test, High-Voltage Transformers .....	93
56	Dielectric Voltage-Withstand Test .....	94
57	Flammability Test .....	94

**MANUFACTURING AND PRODUCTION TESTS**

58	General .....	95
59	Production Line Dielectric Voltage-Withstand Test.....	96

**MARKING**

60	General .....	97
----	---------------	----

**INSTRUCTIONS**

61	Operating and Installation Instructions .....	99
----	---	----

**PART 2 – OUTDOOR-USE EQUIPMENT****CONSTRUCTION**

62	General .....	99
63	Enclosure .....	99
	63.1 General.....	99
	63.2 Corrosion protection.....	100
64	Field-Wiring Connections .....	102
65	Internal Wiring.....	102
66	Electrical Insulating Material.....	102

**PERFORMANCE**

67	Rain Test .....	102
68	Wind Test .....	105
69	Accelerated Aging Test – Gaskets, Adhesives, and Sealing Compounds .....	105
70	Metallic Coating Thickness Test.....	106

**MARKING**

71	General .....	108
----	---------------	-----

**APPENDIX A**

Standards for Components .....	109
--------------------------------	-----

No Text on This Page

[ULNORM.COM](https://ULNORM.COM) : Click to view the full PDF of UL 727 2024

## PART 1 – ALL PRODUCTS

### INTRODUCTION

#### 1 Scope

1.1 These requirements cover oil-fired central furnaces which include forced-air furnaces of the downflow, horizontal, and upflow types. Floor-mounted unit heaters designed to supply heated air through ducts are covered also by these requirements.

1.2 These requirements cover furnaces intended to burn fuel oils as specified in the Specifications for Fuel Oils, ASTM D396, any biodiesel as defined by the Standard Specification for Biodiesel Fuel Blend Stock (B100) for Middle Distillate Fuels, ASTM D6751, or any fuel oil/biodiesel blend..

1.3 The oil-burning equipment covered by these requirements are intended for installation in accordance with the National Fire Protection Association Standard for Installation of Oil-Burning Equipment, NFPA 31, the International Mechanical Code and the Uniform Mechanical Code.

#### 2 Units of Measurement

2.1 Values stated without parentheses are the requirement. Values in parentheses are explanatory or approximate information.

#### 3 Glossary

3.1 For the purpose of this standard the following definitions apply.

3.2 AIR SHUTTER – An adjustable device for varying the size of the air inlet or inlets regulating primary and/or secondary air.

3.3 ANTIFLOODING DEVICE – A primary safety control which causes the fuel flow to be shut off upon a rise in fuel level or upon receiving excess fuel, and that operates before the hazardous discharge of fuel can occur.

3.4 APPLIANCE – Refers to any equipment covered by these requirements unless specifically noted otherwise.

3.5 APPLIANCE FLUE – The flue passages within the appliance.

3.6 AUTOMATICALLY LIGHTED APPLIANCE – An appliance in which fuel to the main burner is turned on and ignited automatically.

3.6A BIODIESEL – Any biodiesel blend stock as defined by Standard Specification for Biodiesel Fuel Blend Stock (B100) for Middle Distillate Fuels, ASTM D6751-20a, intended to be utilized as a complete fuel source (B100) or blended with a distillate fuel oil.

3.7 BURNER, MECHANICAL-ATOMIZING TYPE – A power-operated burner that prepares and delivers the oil and all or part of the air by mechanical process in controllable quantities for combustion. Some examples are air and steam atomizing, high and low pressure atomizing, horizontal rotary, vertical rotary atomizing, and vertical rotary wall-flame burners.

3.8 BURNER, MECHANICAL DRAFT TYPE – A burner that includes a power-driven fan, blower, or other mechanism as the principal means for supplying air for combustion.

3.9 BURNER, NATURAL DRAFT TYPE – A burner that depends principally upon the natural draft created in the flue to induce into the burner the air required for combustion.

3.10 BURNER, VAPORIZING TYPE – A burner consisting of an oil-vaporizing bowl or other receptacle to which liquid fuel may be fed in controllable quantities; the heat of combustion being used to vaporize the fuel, with provision for admitting air and mixing it with the oil vapor in combustible proportions.

3.11 COMBUSTIBLE – Is defined in the Standard Glossary of Terms Relating to Chimneys, Vents, and Heat Producing Appliances, NFPA 97M.

3.12 CONSTANT-LEVEL VALVE – A device for maintaining within a reservoir a constant level of fuel for delivery to the burner.

3.13 CONTROL, LIMIT – As it pertains to this standard, a safety control responsive to changes in temperature normally set beyond the intended operating range of the furnace to limit its operation.

3.14 CONTROL, OPERATING – A control, other than a safety control or interlock, to start or regulate input according to demand, and to stop or regulate input on satisfaction of demand. Operating controls may also actuate auxiliary equipment.

3.15 CONTROL, SAFETY – Automatic controls, including relays, switches, and other auxiliary equipment used in conjunction therewith to form a safety control system, that are intended to reduce the risk of improper operation of the controlled equipment.

3.16 CONTROL, PRIMARY SAFETY – The automatic safety control intended to reduce the risk of abnormal discharge of oil at the burner in case of ignition failure or flame failure.

3.17 CONTROL, SAFETY COMBUSTION – See Control, Primary Safety.

3.18 DRAFT REGULATOR, BAROMETRIC (AUTOMATIC DAMPER) – A device that functions to maintain a desired draft in the appliance by automatically reducing excess chimney draft to the desired value.

3.19 ELECTRICAL CIRCUITS:

a) High-Voltage Circuit – A circuit involving a potential of not more than 600 volts and having circuit characteristics in excess of those of a low-voltage circuit.

b) Low-Voltage Circuit – A circuit involving a potential of not more than 30 volts rms alternating-current (42.4 volts peak) or direct current and supplied by:

1) A Class 2 transformer, or by a battery, by a battery and fixed impedance, or by a transformer and fixed impedance each of which, as a unit is in compliance with what is required for a Class 2 transformer; or

2) Is limited to a maximum of 100 volt-amperes.

A circuit derived from a source of supply classified as a high-voltage circuit, by connecting resistance in series with the supply circuit as a means of limiting the voltage and current, is not considered to be a low-voltage circuit.

c) Isolated Limited Secondary Circuit – A circuit of limited energy derived from an isolated secondary winding of a transformer having a maximum capacity of 100 volt-amperes and open-circuit secondary voltage rating not exceeding 1000 volts.

d) Safety Control Circuit – A circuit involving one or more safety controls.

3.20 FUEL OIL – Any hydrocarbon oil as defined by the Standard Specifications for Fuel Oils, ASTM D396, any biodiesel as defined by the Standard Specification for Biodiesel Fuel Blend Stock (B100) for Middle Distillate Fuels ASTM D6751, or any fuel oil/biodiesel blend.

3.20A FUEL OIL/BIODIESEL BLEND – Blended fuels consisting of a No. 2 or lighter fuel oil component and a biodiesel component. The biodiesel component shall meet the Standard Specification for Biodiesel Fuel Blend Stock (B100) for Middle Distillate Fuels, ASTM D6751. The numerical value corresponding to the biodiesel component determines the blend rating (such as B20 for 20 % biodiesel, 80 % fuel oil).

3.21 FURNACE, CENTRAL WARM-AIR – A self-contained indirect-fired appliance constructed to supply heated air through ducts to spaces remote from or adjacent to the appliance location.

3.22 FURNACE, ATTIC CENTRAL – A forced-air type central furnace designed specifically for installation in an attic or in a space with low headroom, normally unoccupied.

3.23 FURNACE, DOWNFLOW – A forced-air type central furnace constructed with air flow through the furnace essentially in a vertical path, discharging air at or near the bottom of the furnace. See [Figure 3.1](#).

ULNORM.COM : Click to view the full PDF of UL 727 2024

Figure 3.1  
Types of forced-air central furnaces

UPFLOW FURNACE

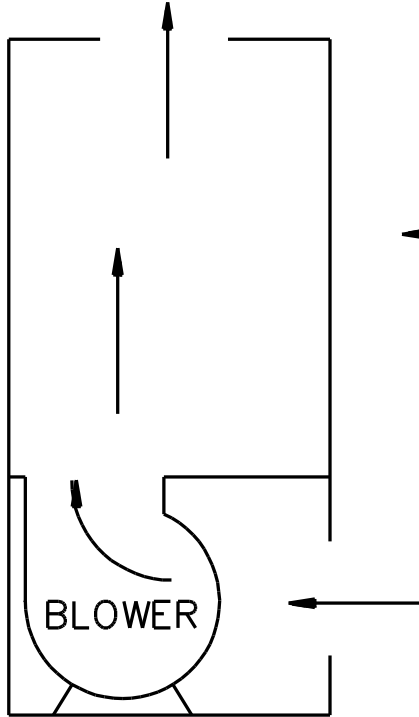

HORIZONTAL FURNACE

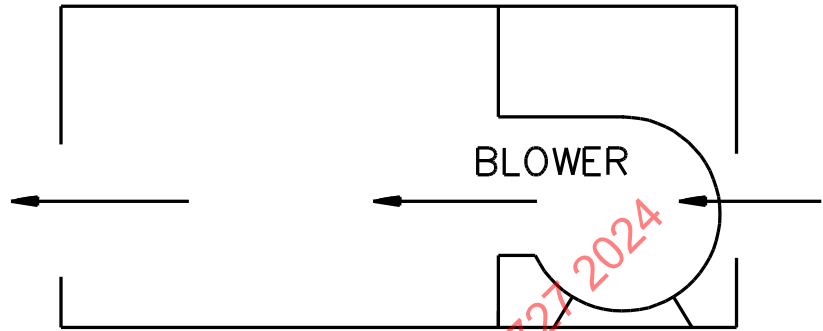

DOWNFLOW FURNACE

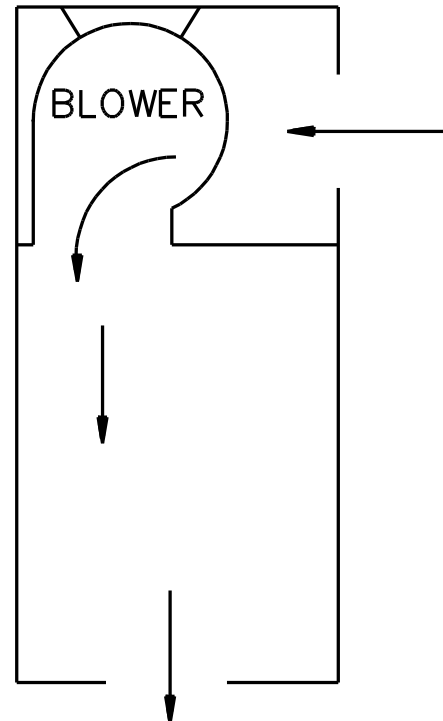

UPFLOW FURNACE

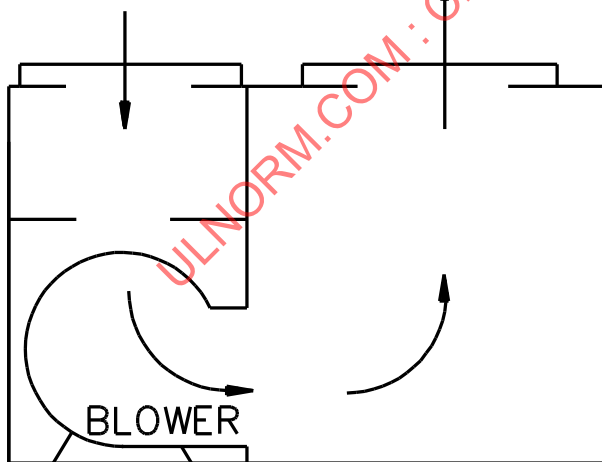

S2590

Note: Arrows indicate direction of air flow.

3.24 FURNACE, HORIZONTAL – A forced-air type central furnace constructed with air flow through the furnace essentially in a horizontal path. See [Figure 3.1](#).

3.25 FURNACE, UPFLOW – A central furnace constructed with air flow through the furnace essentially in a vertical path, discharging air at or near the top of the furnace. See [Figure 3.1](#).

3.26 INDIRECT-FIRED APPLIANCE – An appliance constructed so that combustion products or flue gases are not mixed in the appliance with the medium, that is, to be heated; hence is provided with a flue collar.

3.27 NONCOMBUSTIBLE – Is defined in the standard Glossary of Terms Relating to Chimneys, Vents, and Heating Producing Appliances, NFPA 97M.

3.28 RADIATION SHIELD – A separate panel or panels interposed between heating surfaces and adjacent objects to reduce heat transmission by radiation.

3.29 RADIATOR – Auxiliary heat transfer surfaces within the casing, connected between the combustion chamber and the flue collar.

3.30 SERVICING – The periodic tasks usually performed to operate and maintain an appliance, such as air, fuel, pressure, and temperature regulation, cleaning, lubrication, and resetting of controls. Repair and replacement of parts other than those expected to be renewed periodically is not considered to be servicing. Some examples of servicing are:

- a) Cleaning or replacing nozzles, atomizers, and pilots.
- b) Setting ignition electrodes.
- c) Cleaning strainers or replacing strainer or filter element.
- d) Resetting safety control.
- e) Replacing igniter cable.

3.31 VALVE, MANUAL OIL SHUT-OFF – A manually operated valve in the oil line for the purpose of completely turning on or shutting off the oil supply to the burner.

3.32 VALVE, OIL CONTROL – An automatically or manually operated device consisting essentially of an oil valve for controlling the fuel supply to a burner.

- a) Metering (Regulating) Valve – An oil control valve for regulating burner input.
- b) Safety Valve – A normally closed valve of the "on" and "off" type, without any bypass to the burner, that is actuated by a safety control or by an emergency device.

3.33 VENTED APPLIANCE – An indirect-fired appliance provided with a flue collar to accommodate a flue pipe for conveying flue gases to the outer air.

## 4 Components

4.1 Except as indicated in [4.2](#), a component of a product covered by this standard shall comply with the requirements for that component. See Appendix [A](#) for a list of standards covering components generally used in the products covered by this standard.

4.2 A component is not required to comply with a specific requirement that:

- a) Involves a feature or characteristic not required in the application of the component in the product covered by this standard, or
- b) Is superseded by a requirement in this standard.

4.3 A component shall be used in accordance with its rating established for the intended conditions of use.

4.4 Specific components are incomplete in construction features or restricted in performance capabilities. Such components are intended for use only under limited conditions, such as certain temperatures not exceeding specified limits, and shall be used only under those specific conditions.

## CONSTRUCTION – MECHANICAL

### 5 Assembly

5.1 A furnace shall be factory-built as a group assembly and shall include all the essential components necessary for its intended function when installed as intended. An oil-fired furnace may be shipped as two or more major subassemblies.

5.2 A furnace, if not assembled by the manufacturer as a unit, shall be arranged in major subassemblies. Each subassembly shall be capable of being incorporated into the final assembly without requiring alteration, cutting, drilling (except to the extent indicated in [5.3](#)), threading, welding, or similar tasks by the installer. Two or more subassemblies, that must bear a definite relationship to each other for the intended installation or operation of the furnace, shall be arranged and constructed to permit them to be incorporated into the complete assembly, only in the correct relationship with each other without need for alteration or alignment, or such subassemblies shall be assembled, tested, and shipped from the factory as one element.

5.3 To be in accordance with [5.2](#), major subassemblies of a furnace are deemed to be:

- a) The burner;
- b) The heat exchanger, including its base, combustion chamber, casing, and safety controls;
- c) The blower assembly, including the base, filters, and casing; and
- d) The blower motor if not included as part of the blower assembly.

A wiring harness may be packaged with one of the major subassemblies.

5.4 Cutting or drilling which is required for the attachment of a return or supply plenum, an optional filter rack, or to cut a return air opening in the furnace casing is deemed to conform to [5.2](#). If a return air opening is to be cut in the casing panel by the installer, suitable instructions and a template shall be furnished with the furnace, or the corners of the opening shall be embossed in knock-out form.

5.5 A radiation shield or baffle employed to prevent temperatures in excess of those intended, shall be assembled as part of the furnace; or be part of a subassembly that must be attached to the furnace for its intended operation; or be constructed so that the furnace cannot be assembled for operation without first attaching a required shield or baffle in its intended position.

5.6 The construction of a furnace shall be such that, for any intended installation, the alteration or removal of a baffle, insulation, or a radiation shield needed to reduce the risk of temperatures that may result in a risk of fire, electric shock, or injury to persons, is not required.

5.7 A horizontal furnace intended for suspended installation shall be provided with brackets or hangers to support the furnace from its basic frame or structure.

5.8 A furnace shall provide for convenient operation of those parts requiring attention or manipulation by the user during intended usage.

5.9 Adjustable or movable parts shall be provided with locking devices to reduce the risk of unintentional shifting.

5.10 Screws or bolts used to attach parts that are detached for care or servicing of the appliance shall be capable of holding upon the application of the torques indicated in [Table 5.1](#) after removal and replacement.

**Table 5.1**  
**Maximum torque requirements for screw or bolts**

American standard screw size		Torque		I.S.O. screw size	Torque	
No.	mm	Lb-in.	N·m	mm	N·m	Lb-in.
–	–	–	–	4	1.6	14
8	4.2	18	2.0	4.5	2.6	23
10	4.8	30	3.4	5	4.2	37
Inch	mm					
1/4	6.4	100	11.3	6	8.7	77
–	–	–	–	7	15.0	133
5/16	7.9	200	22.6	8	23.5	208
–	–	–	–	9	33.6	297
3/8	9.5	350	39.6	10	45.2	400
7/16	11.1	575	65.0	12	81.0	715
1/2	12.7	850	96.0	14	128.0	1130
9/16	14.3	1200	136.0	–	–	–
5/8	15.9	1600	181.0	16	185.0	1640

5.11 Any external door providing access into the combustion chamber of a furnace intended for installation with a clearance of less than 24 inches (610 mm) from the face of or 48 inches (1220 mm) above the door shall be self-closing.

5.12 A furnace intended for installation in the cooled-air path, downstream from a cooling coil, shall conform to the following:

- a) All interior surfaces of the heat exchanger, combustion chamber including its bottom, radiators, and flues shall be resistant to corrosion by moisture.
- b) The firebox liner shall resist deterioration from being wetted by condensation.
- c) Condensation shall not drip on burner parts or other corrodible parts if corrosion of any such parts may cause operation that may result in a risk of fire, electric shock, or injury to persons.
- d) The heat exchanger and appliance flue shall contain no traps or pockets in which condensation may collect.

5.13 A burner shall be secured so it will not twist, slide, or drop out of position.

5.14 A furnace equipped with an antiflooding device shall be constructed so that, when the furnace is level, the minimum distance between the designed maximum intended oil level maintained by the oil control device and the level of the lowest point at which overflow may occur is not less than 3/4 inch (19.1 mm).

## 6 Servicing

### 6.1 General

6.1.1 A furnace shall be provided with means of access for cleaning of parts such as interior surfaces of vaporizing burners, heating surfaces in contact with combustion products, oil inlet pipes, and oil strainers, without major dismantling of the furnace or removal of parts required to be factory-assembled.

6.1.2 The removal of access panels, burners, blowers, caps, plugs, and the like, permitting removal and replacement for servicing, and the detachment of the chimney connector are not considered major dismantling as defined by [6.1.1](#).

6.1.3 Accessibility shall be afforded for cleaning, inspection, repair, and replacement of all burners, controls, and safety devices when the furnace is installed as intended by the manufacturer. The disposition of parts in the assembly removed for servicing shall be such that their restoration, following removal, will not necessitate their realignment to secure their intended relationship with other parts of the assembly. Special facilities required for servicing to be performed by the operator shall accompany the furnace and be attached to or placed, per instructions, near the furnace at the time of installation.

6.1.4 The requirements of [36.1](#) are not applicable to mechanical service functions which are not normally performed with the equipment energized. Such functions include adjusting or replacing belts and cleaning and replacement of strainers and oil filters.

### 6.2 Moving parts

6.2.1 Moving parts such as fan blades, blower wheels, pulleys, or belts which may cause injury shall be enclosed or guarded.

6.2.2 If the removal of doors or panels or shields will expose such moving parts:

- a) The opening or removal of the door, panel or shield shall require the use of tools; or
- b) An interlocking device shall shut off the mechanism; or
- c) A warning marking shall be displayed which reads essentially as follows:

"DANGER – TO AVOID INJURY FROM MOVING PARTS, SHUT OFF THE (EQUIPMENT) BEFORE (REMOVING-OPENING) THIS (COVER DOOR)."

6.2.3 The distance from an opening in a required guard or enclosure to the moving part mentioned in [6.2.1](#) shall be in accordance with [Table 6.1](#), but the minor dimension of the opening shall not in any case exceed 3 inches (76 mm). For an opening having a minor dimension intermediate between two of the values included in the table, the distance from the opening to the moving part shall be not less than that found by appropriate interpolation between the corresponding values in the right-hand column of the table. The minor dimension of the opening is determined by the largest hemispherically tipped cylindrical probe that can be inserted through the opening with a force of 5 pounds (22 N).

6.2.4 A moving part is not to be considered when judging compliance with [6.2.1](#) and [36.1](#) if the part is unlikely to be contacted through the opening because of fixed components, including baffles.

**Table 6.1**  
**Dimensions of openings**

Minor dimensions of openings <sup>a</sup>		Minimum distance from opening to moving part	
Inches	(mm)	Inches	(mm)
1/4	(6.4)	1/2	(12.7)
3/8	(9.5)	1-1/2	(38.1)
1/2	(12.7)	2-1/2	(63.5)
3/4	(19.1)	4-1/2	(114.0)
1	(25.4)	6-1/2	(165.0)
1-1/2	(38.1)	10-1/2	(267.0)
2	(50.8)	14-1/2	(368.0)
Over 2 inch (over 50.8)		30	(762.0)

<sup>a</sup> Openings less than 1/4 inch (6.4 mm) are not to be considered.

## 7 Disposal of Combustion Products

7.1 The construction of a furnace shall not allow the products of combustion to become mixed with the circulating air.

## 8 Base

8.1 The base of a furnace shall be constructed of metal or fabricated of other nonflammable material in a manner to provide equivalent strength and durability. The assembly shall be constructed so that there will be no open passages in the floor through which flame or hot gases from a fire originating in the space below the floor can travel to the room above when the furnace is installed as intended.

8.2 A subbase, if furnished as a separate assembly, shall be arranged for attachment to the furnace in the intended position only and in a manner that will establish and maintain correctly the position of the furnace with respect to the subbase.

8.3 The base and subbase of a downflow furnace intended for installation on flammable flooring material shall establish and maintain not less than the required clearance between vertical surfaces of the plenum or duct to be attached thereto and the floor construction. A spacer shall extend at least 3 inches (76 mm) below the upper surface of the floor on which the furnace is to be installed. An acceptable base design is shown in [Figure 8.1](#).

Figure 8.1  
Acceptable base construction for downflow furnace

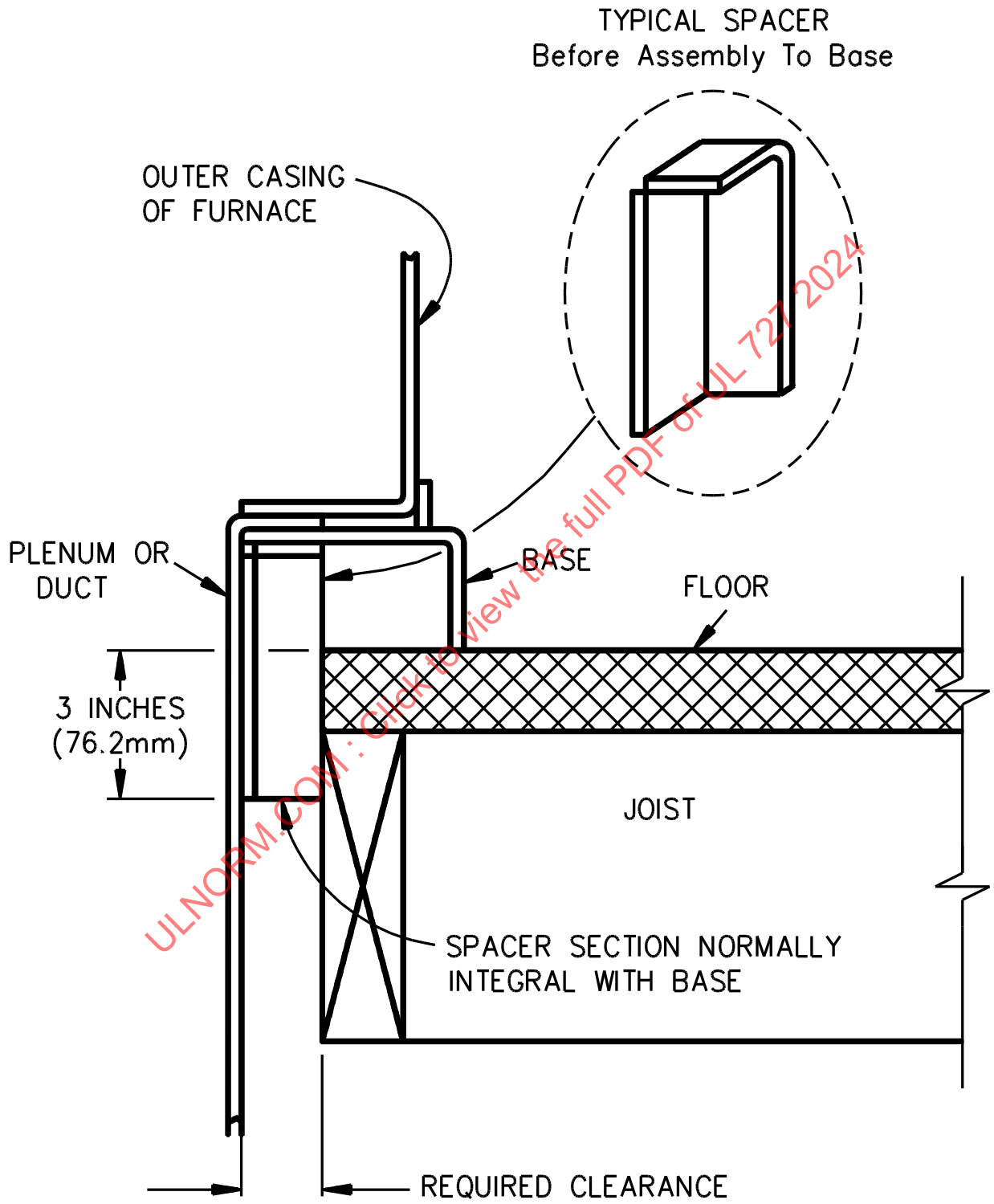

8.4 The use of spacers in the form of separate blocks or shims is not considered to be in accordance with 8.3. This latter type of construction is shown in [Figure 8.2](#).

**Figure 8.2**  
**Unacceptable base construction for downflow furnace**

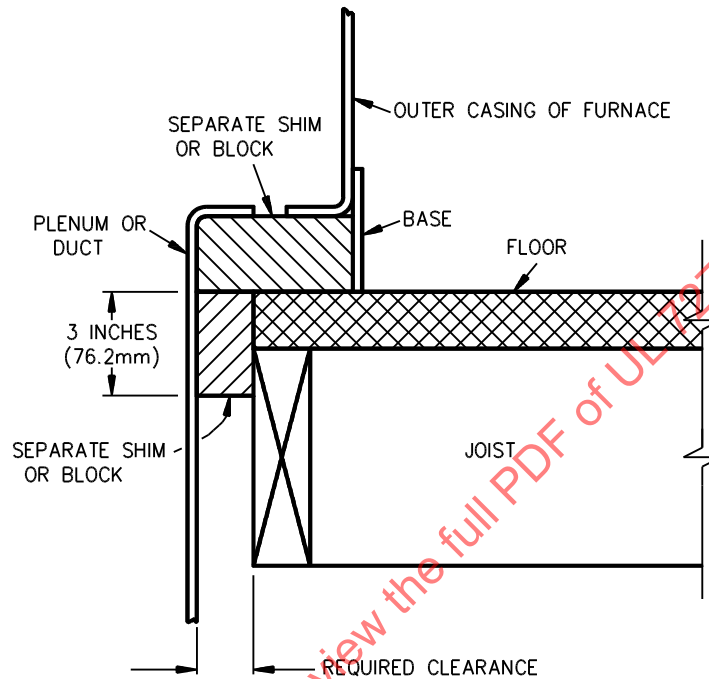

S2592

## 9 Casings

9.1 An outer casing or jacket shall be made of steel or equivalent material, braced, reinforced or formed to avoid damage through handling in shipment, installation, and use. Sheet metal casings shall be made of steel having a minimum thickness of 0.020 inch (0.51 mm) if uncoated, or 0.023 inch (0.58 mm) if galvanized, or of nonferrous sheet metal having an average thickness of not less than 0.029 inch (0.74 mm).

9.2 Access panels which may be removed for servicing and accessibility shall be constructed to permit removal and replacement repeatedly without causing damage or impairing any required insulating value.

9.3 A removable panel through which air is drawn for combustion shall be so constructed as to prevent it from being attached in a manner that may affect the intended performance of the furnace.

9.4 A removable panel shall be so constructed that it will not be interchangeable with other panels on the same furnace if interchange may affect the intended operation of the furnace.

9.5 The casing of a furnace for installation on combustible flooring material shall completely close the bottom or be constructed to provide an effective radiation barrier between the heat exchanger and the floor; except an opening intended to be always connected to a circulating-air distribution duct may be permitted.

9.6 The casing of a forced-air type furnace shall have no uncovered openings communicating with the circulating air compartments unless such openings are intended to be always connected to a circulating air distribution duct.

9.7 The furnace shall be constructed so that a negative pressure created by an air-circulating fan cannot affect the combustion air supply or draw products of combustion into the circulating air.

9.8 A connection between the heat exchanger and the casing which encloses circulating air shall be constructed to prevent leakage of combustion products into the circulating air.

9.9 An access opening to a return-air compartment shall be completely covered.

9.10 A central furnace shall provide for the attachment of warm-air outlet and cold-air return ducts.

*Exception: A furnace arranged for a specific kind of installation permitted to be made without outlet or return air ducts may be tested for such restricted use.*

9.11 An integral plenum of a furnace for alcove or closet installation shall have not more than one outlet-air opening unless each additional opening is provided with means supplied at the factory to close the openings in the casing and any insulation or liner.

## 10 Radiation Shields or Liners

10.1 A radiation shield or liner shall be so constructed, formed, and supported so as to provide for the intended positioning and to prevent distortion or sagging in service. A shield or liner shall be protected against corrosion if its deterioration may cause excessive temperature when the furnace is tested in accordance with these requirements. Any finish to obtain the required resistance to corrosion shall not be damaged by heat when the furnace is tested under these requirements.

## 11 Materials in Air Handling Compartments

11.1 Materials in a compartment handling air for circulation through a duct system shall not have a flame spread rating over 25 nor a smoke developed rating over 50 when tested in accordance with the Standard for Test for Surface Burning Characteristics of Building Materials, UL 723. This requirement does not apply to the following:

- a) Air filters, drive belts, wire insulation, and paint as applied for corrosion protection.
- b) Gaskets forming air or water seals between metal parts.
- c) Miscellaneous small parts such as resilient or vibration mounts, wire ties, clamps, labels, and the like.
- d) An adhesive which, when tested in combination with the specific insulating material, complies with the requirement.
- e) Molded or formed components made of polymeric materials, not liners, in such quantity that the total surface area of such materials in the compartment does not exceed 10 square feet (0.93 m<sup>2</sup>). See [11.7](#).

11.2 The supporting surface to be used in the surface burning characteristics test of adhesives is to be of asbestos-cement board or metal. Other materials requiring support may be supported using metal rods or bars or 2-inch (51-mm) hexagonal mesh-wire with metal bars or rods.

11.3 Exposed unimpregnated asbestos material shall not be used in an air-handling compartment. The unprotected edge of a gasket sandwiched between two parts is considered to be exposed.

11.4 Thermal or acoustic insulating material shall be secured in position if:

- a) Loosening may reduce or block air flow to cause temperatures or pressures in excess of those acceptable in the temperature tests; or
- b) Loosening will result in reduction of electrical spacings below the required values, short-circuiting, or grounding.

Leading edges of insulation shall be protected against damage from the effects of the velocity of the moving air.

11.5 Mechanical fasteners for securing the insulating liner in position shall be used for each square foot (0.09 m<sup>2</sup>) unless the liner is retained in position under all test conditions by a lesser number of fasteners because of its inherent rigidity. Mechanical fasteners may be bolts, metal clamps, wire rods, or the equivalent. Butting edges of insulation against bulkheads provides protection for leading edges against damage from effects of the velocity of moving air.

11.6 An adhesive required for securing insulation shall retain its adhesive qualities at any temperature attained by the adhesive when the unit is tested under the performance requirements of this standard and at 0°F (minus 17.8°C) or minus 20°F (minus 29°C) for outdoor-use equipment.

11.7 Polymeric materials exempted by [11.1\(e\)](#) shall not have a flame spread rating exceeding 25 or shall conform to the Flammability Test requirements of Section [57](#).

## 12 Air Filters

12.1 An air filter, if supplied as a part of the furnace, shall be accessible for inspection or replacement without the use of special tools and without dismantling the furnace.

## 13 Combustion Chambers

13.1 A combustion chamber and flueway within the air handling compartment shall be constructed of cast iron, sheet steel, or equivalent material. Sheet steel, if used, shall be such as to provide the strength, rigidity, durability, resistance to corrosion, and other physical properties equivalent to sheet steel having a minimum thickness of 0.042 inch (1.07 mm).

13.2 Combustion chamber (firebox) lining material, if used, shall be secured in place, and accessible for replacement with equivalent material.

## 14 Radiators

14.1 A radiator shall be made of material not lighter than that designated in [13.1](#) for a combustion chamber and shall be accessible for cleaning.

## 15 Heating Surface Joints

15.1 Joints in heating surfaces shall be welded, locked-seamed, machined and bolted or riveted. The tightness of a joint shall be equivalent to that afforded by lock-seaming and shall not depend primarily on cement for tightness. A slip or lap joint shall not depend solely upon friction of the joint itself for strength.

15.2 Examples of some acceptable lock-seams are illustrated by [Figure 15.1](#).