



UL 67

STANDARD FOR SAFETY

Panelboards

[ULNORM.COM](https://www.ulnorm.com) : Click to view the full PDF of UL 67 2023

ULNORM.COM : Click to view the full PDF of UL 67 2023

UL Standard for Safety for Panelboards, UL 67

Thirteenth Edition, Dated May 15, 2018

SUMMARY OF TOPICS:

This revision of ANSI/UL 67 dated May 16, 2023, includes the following changes in requirements:

- Inclusion of Requirements for Energy Management Systems; [5.26A](#), [6.6.11](#), [6.6.12](#) and [34.16.7](#).***
- Inclusion of Requirements for Short-Circuit Current Rating (SCCR) for DC Rated Panelboards; [5.39](#), [5.60](#), [21.1.10](#), [21.4.1.3](#), [25.1.1](#), [25.8.1.2](#), [25.8.4.1](#), [25.8.4.2](#), [Table 25.4A](#), [25.8.4.3](#), [Table 33.1](#), [34.1.18](#), [34.1.20](#), [34.1.22](#) and [34.12.9](#)***
- Clarification of Requirements Regarding Ventilating Openings in Panelboards; [7.3.1.1](#).***
- Addition of Requirements for Interconnection Equipment; [28.2](#), [34.12.18](#) and [34.12.19](#)***
- Correction of Rating Requirements for Panelboards Marked as Suitable for Use as Service Equipment in Section 31; [31.5](#) – [31.8](#).***

Text that has been changed in any manner or impacted by ULSE's electronic publishing system is marked with a vertical line in the margin.

The new and revised requirements are substantially in accordance with Proposal(s) on this subject dated March 3, 2023.

All rights reserved. No part of this publication may be reproduced, stored in a retrieval system, or transmitted in any form by any means, electronic, mechanical photocopying, recording, or otherwise without prior permission of ULSE Inc. (ULSE).

ULSE provides this Standard "as is" without warranty of any kind, either expressed or implied, including but not limited to, the implied warranties of merchantability or fitness for any purpose.

In no event will ULSE be liable for any special, incidental, consequential, indirect or similar damages, including loss of profits, lost savings, loss of data, or any other damages arising out of the use of or the inability to use this Standard, even if ULSE or an authorized ULSE representative has been advised of the possibility of such damage. In no event shall ULSE's liability for any damage ever exceed the price paid for this Standard, regardless of the form of the claim.

Users of the electronic versions of UL's Standards for Safety agree to defend, indemnify, and hold ULSE harmless from and against any loss, expense, liability, damage, claim, or judgment (including reasonable attorney's fees) resulting from any error or deviation introduced while purchaser is storing an electronic Standard on the purchaser's computer system.

No Text on This Page

ULNORM.COM : Click to view the full PDF of UL 67 2023

MAY 15, 2018
(Title Page Reprinted: May 16, 2023)



ANSI/UL 67-2023

1

UL 67

Standard for Panelboards

First Edition – November, 1917
Second Edition – July, 1928
Third Edition – April, 1931
Fourth Edition – March, 1941
Fifth Edition – November, 1948
Sixth Edition – May, 1965
Seventh Edition – July, 1967
Eighth Edition – August, 1974
Ninth Edition – August, 1979
Tenth Edition – October, 1988
Eleventh Edition – December, 1993
Twelfth Edition – March, 2009

Thirteenth Edition

May 15, 2018

This ANSI/UL Standard for Safety consists of the Thirteenth Edition including revisions through May 16, 2023.

The most recent designation of ANSI/UL 67 as an American National Standard (ANSI) occurred on May 16, 2023. ANSI approval for a standard does not include the Cover Page, Transmittal Pages, and Title Page.

The Department of Defense (DoD) has adopted UL 67 on June 18, 1990. The publication of revised pages or a new edition of this Standard will not invalidate the DoD adoption.

Comments or proposals for revisions on any part of the Standard may be submitted to ULSE at any time. Proposals should be submitted via a Proposal Request in ULSE's Collaborative Standards Development System (CSDS) at <https://csds.ul.com>.

Our Standards for Safety are copyrighted by ULSE Inc. Neither a printed nor electronic copy of a Standard should be altered in any way. All of our Standards and all copyrights, ownerships, and rights regarding those Standards shall remain the sole and exclusive property of ULSE Inc.

COPYRIGHT © 2023 ULSE INC.

No Text on This Page

ULNORM.COM : Click to view the full PDF of UL 67 2023

CONTENTS

INTRODUCTION

1	Scope	7
2	Components	7
3	Units of Measurement	9
4	Undated References	9
5	Glossary	9

CONSTRUCTION

6	General	17
	6.1 All panelboards	17
	6.2 Equipment on supply side of disconnect	17
	6.3 Distribution equipment	18
	6.4 Service equipment	18
	6.5 Branch circuits	20
	6.6 Electrical connections	20
	6.7 Field installable equipment	22
7	Enclosure	23
	7.1 General	23
	7.2 Component arrangement	24
	7.3 Ventilating openings	24
8	Bases and Supports – Insulating Material	26
9	Covers, Barriers, and Partitions	27
	9.1 General	27
	9.2 Bushings	31
10	Filler Plates	31
11	Current-Carrying Parts	32
	11.1 General	32
	11.2 Bus bars, supports	34
	11.3 Ampacity General	36
	11.4 Main unit ratings	39
	11.5 Neutral	40
	11.6 Fuseholders and circuit breakers	41
12	Wiring Terminals	41
	12.1 General	41
	12.2 Screw terminals	43
13	Cord-Connectors	45
	13.1 General	45
	13.2 Input connections	45
	13.3 Output connections	46
14	Switches, Circuit Breakers, and Overcurrent-Protective Devices	47
	14.1 General	47
	14.2 Ratings	48
	14.3 Main and main-disconnect switches and circuit breakers	48
	14.4 Switches	48
	14.5 Overcurrent protective devices	49
	14.6 Lighting and appliance panelboards	49
	14.7 Fuseholders	49
	14.8 Panelboards with integral inlet	50
15	Ground-Fault Protection	50
16	Spacings	52
	16.1 General	52

16.2	Switches	56
16.3	Barriers and liners.....	56
16.4	Tape	58
16.5	Tubing	59
17	Wiring Space, Wiring Gutters, and Wire Bending Space	59
17.1	General.....	59
17.2	Wiring space, wiring gutters, and terminal compartments.....	63
17.3	Wire deflection and bending space.....	67
17.4	Determination of deflection and bending space distances	68
18	Grounding and Bonding	74
18.1	General.....	74
18.2	Equipment-grounding terminals	76
19	Sharp Edges.....	78
20	Separation of Circuits	79

PERFORMANCE

21	Temperature Test	79
21.1	General.....	79
21.2	Main lug	82
21.3	Main circuit breaker.....	83
21.4	Neutral	83
21.5	Clamped joints	84
21.6	Other bus bar coatings	85
21.7	Joints with insulators	85
22	Rain Test	85
23	Strength of Insulating Base and Support Test.....	86
24	Mold Stress Relief Test	86
25	Short-Circuit Current Test.....	86
25.1	General.....	86
25.2	Sample selection	89
25.3	Sample preparation	90
25.4	Line connections.....	90
25.5	Load connections	94
25.6	Fuses	94
25.7	Meter mounting positions	96
25.8	Short-circuit procedure.....	96
25.9	Short-circuit tests.....	98
25.10	Evaluation of test results.....	99
26	Dielectric Voltage-Withstand Test	99
26.1	General	99
26.2	Joints with insulators	100
26.3	After short circuit.....	100
26.4	Insulating barriers	101
27	Bonding Resistance Test.....	101
28	Test Requirements for Panelboards Used as Transfer Equipment	101

MANUFACTURING AND PRODUCTION TESTS

29	Ground-Fault Protection Test.....	101
----	-----------------------------------	-----

RATING

30	General	102
31	Current.....	102

32	Voltage	103
33	Short Circuit Current – Details	104

MARKING

34	Details	104
34.1	General	104
34.2	Wiring space and terminals	109
34.3	Field-installed conductors	110
34.4	Arrangement of terminals	110
34.5	Tightening torque	111
34.6	Enclosure type marking	113
34.7	Switches and circuit breakers	114
34.8	Lighting and appliance panelboards	114
34.9	Service equipment	115
34.10	Ground-fault protection	116
34.11	Distribution equipment	116
34.12	Field-installed equipment	117
34.13	Equipment-grounding terminals	119
34.14	Filler plates	120
34.15	Neutral	120
34.16	Parallel Power Source Panelboard	120
34.17	Panelboard with connection to Uninterruptible Power Supply	121
34.18	Panelboard with provisions for cord connections	121
35	Permanence of Marking	122

INSTALLATION INSTRUCTIONS

36	Field Testing of Ground-Fault Protection of Equipment	123
----	---	-----

SUPPLEMENT SA – PANELBOARDS FOR USE UNDER USCG ELECTRICAL ENGINEERING REGULATIONS SUBCHAPTER J (46 CFR, PARTS 110 – 113)

PANELBOARDS FOR MARINE USE

SA1	Scope	125
SA2	Enclosure	125
SA3	Current-Carrying Parts	126
SA4	Switches, Circuit Breakers, and Overcurrent Protection	126
SA5	Insulating Material	126
SA6	Marking	126

SUPPLEMENT SB – CLASSIFIED CIRCUIT BREAKERS FOR USE WITH SPECIFIED PANELBOARDS AS AN ALTERNATE FOR SPECIFIED CIRCUIT BREAKERS

INTRODUCTION

SB1	Scope	127
SB2	Glossary	127

CONSTRUCTION

SB3	General	127
-----	---------------	-----

PERFORMANCE

SB4	General.....	127
SB5	Insertion and Withdrawal Test.....	128
SB6	Temperature Test.....	128
SB7	Short-Circuit Current Test.....	128

MARKING

SB8	Details	129
-----	---------------	-----

SUPPLEMENT SC – CLASSIFIED MOLDED-CASE SURGE PROTECTIVE DEVICES (SPDs) FOR USE WITH SPECIFIED PANELBOARDS**INTRODUCTION**

SC1	Scope.....	131
SC2	Glossary	131

CONSTRUCTION

SC3	General	131
-----	---------------	-----

PERFORMANCE

SC4	General	132
SC5	Insertion and Withdrawal Test.....	132

MARKING

SC6	Details	132
-----	---------------	-----

APPENDIX A Standards for Components**Appendix B (Informative) Explanatory Information Regarding Wire Deflection And Bending Distances**

ULNORM.COM : Click to view the full PDF of UL 67 2023

INTRODUCTION

1 Scope

1.1 These requirements cover panelboards to be employed in accordance with the National Electrical Code, NFPA 70.

1.2 These requirements cover panelboards for the control and protection electrical circuits.

1.3 These requirements do not cover:

- a) Distribution equipment which sole function is the automatic or nonautomatic transferring of one or more load conductor connections from one power source to another. Reference the Standard for Transfer Switch Equipment, UL 1008.
- b) Factory wired assemblies of industrial control equipment intended to control industrial processes. Reference the Standard for Industrial Control Panels, UL 508A.
- c) Distribution equipment containing only one circuit subdivision, unless also provided with a meter socket. See [6.5.1](#). Reference the Standard for Molded-Case Circuit Breakers, Molded-Case Switches and Circuit-Breaker Enclosures, UL 489.
- d) Distribution equipment intended to serve as a means for distributing power required to operate mobile or temporarily installed equipment. Reference the Standard for Power Outlets, UL 231.
- e) Factory wired assemblies of controllers, timers, temperature regulating equipment and such, intended for control of equipment for use with swimming pools, hot tubs, and/or spas. Reference the Standard for Electric Spas, Equipment Assemblies, and Associated Equipment, UL 1563.
- f) Factory wired assemblies intended for the control of Architectural and Floating Fountains. Reference the Standards for Motor-Operated Water Pumps, UL 778, Underwater Luminaires and Submersible Junction Boxes, UL 676 and Industrial Control Panels, UL 508A.
- g) Portable power distribution equipment. Reference the Standard for Portable Power-Distribution Equipment, UL 1640.
- h) Panelboards with converter and/or inverter functions, intended for use as distribution equipment in recreational vehicles. Reference the Standard for Power Converters/Inverters and Power Converter/Inverter Systems for Land Vehicles and Marine Crafts, UL 458.

2 Components

2.1 Except as indicated in [2.2](#), a component of a product covered by this standard shall comply with the requirements for that component. See Appendix [A](#) for a list of standards covering components generally used in the products covered by this standard.

2.2 A component is not required to comply with a specific requirement that:

- a) Involves a feature or characteristic not required in the application of the component in the product covered by this standard, or
- b) Is superseded by a requirement in this standard.

2.3 A component shall be used in accordance with its rating established for the intended conditions of use.

2.4 Specific components are incomplete in construction features or restricted in performance capabilities. Such components are intended for use only under limited conditions, such as certain temperatures not exceeding specified limits, and shall be used only under those specific conditions.

2.5 A component not marked with a short-circuit current rating is considered rated for use in a circuit having a maximum available fault current as shown in [Table 2.1](#).

Table 2.1
Assumed maximum short-circuit current rating for unmarked components

Components		Short circuit current rating, kA
1.	Circuit Breaker (Including GFCI Type)	5
2.	Clock-Operated Switch	5
3.	Fuseholder	10
4.	Plug Fuse	10
5.	Industrial Control Equipment:	
a.	Auxiliary Devices	5
b.	Switches	5
6.	Meter Socket Base	10
7.	Motor Controller, rated in horsepower (kW)	
a.	1.5 – 50 (1.1 – 37.3)	5
b.	51 – 200 (38 – 149)	10
c.	201 – 400 (150 – 298)	18
d.	401 – 600 (299 – 447)	30
e.	601 – 900 (448 – 671)	42
f.	901 – 1600 (672 – 1193)	85
8.	Photoelectric Switches	5
9.	Receptacle (GFCI Type)	2 ^a
10.	Receptacle (other than GFCI Type)	10
11.	Snap Switch	5
12.	Terminal Block	10
13.	Thermostat	5
14.	Direct Connected Meters	b
^a The short-circuit current available in a 120 volt secondary circuit of a transformer rated 5 kilovolt-amperes or less is considered to be 2 kiloamperes or less.		
^b See 2.7 .		

2.6 The short-circuit current available in the secondary circuit of a transformer rated 10 kilovolt-amperes or less is considered to be 5000 amperes or less.

2.7 For other than a plug-in meter, a current-sensing meter in a panelboard shall be a type that has been subjected to a 60 hertz rms short-circuit current of 12,000 amperes for four electrical cycles, and a peak current of 30,000 amperes for one-half electrical cycle, and shall be provided with overcurrent protection as described in [25.8.5.2](#). A plug-in meter such as a watt-hour meter to be plugged into a meter socket base is not considered to be a part of the panelboard.

Exception No. 1: A meter need not have been tested nor provided with overcurrent protection if it is intended for use with a current transformer.

Exception No. 2: A meter need not have been tested nor provided with overcurrent protection if it is used across a shunt that has been subjected to a short-circuit test as specified in Section 25, Short-Circuit Current Test.

Exception No. 3: A meter need not have been subjected to a peak current of 30,000 amperes nor provided with overcurrent protection if the short-circuit current rating of the panelboard or the available fault current of the circuit at the meter is 14,000 amperes or less.

Exception No. 4: The four electrical cycle test may be reduced to 10,000 amperes if the short-circuit current rating of the panelboard is 10,000 amperes or less.

3 Units of Measurement

3.1 Values stated without parentheses are the requirement. Values in parentheses are explanatory or approximate information.

4 Undated References

4.1 Any undated reference to a code or standard appearing in the requirements of this standard shall be interpreted as referring to the latest edition of that code or standard.

5 Glossary

5.1 For the purpose of this standard, the following definitions apply.

5.2 **AMBIENT TEMPERATURE** – The temperature of the surrounding medium that comes in contact with the panelboard. For an enclosed panelboard, it is the temperature of the medium outside the enclosure.

5.3 **AMPACITY** – The current in amperes a conductor can carry continuously under the conditions of use without exceeding its temperature rating.

5.4 **AVAILABLE SHORT-CIRCUIT CURRENT** – That current which would flow in a circuit if a short-circuit of negligible impedance were to occur at a given point.

5.5 **BARRIER** – A partition for the insulation or isolation of electric circuits or electric arcs.

5.6 **BONDING** – The permanent joining of metallic parts to form an electrical conductive path that ensures electrical continuity and the capacity to conduct safely any current likely to be imposed.

5.7 **BONDING JUMPER** – A reliable conductor to ensure the required electrical conductivity between metal parts required to be electrically connected.

5.8 **BONDING SCREW** – A screw that is used as a bonding jumper.

5.9 **BUS** – A conductor, or group of conductors, that serves as a common connection for two or more circuits.

5.10 **CABINET** – An enclosure designed for either surface mounting or flush mounting and is provided with a frame, mat, or trim in which a swinging door or doors are or can be hung.

5.11 **CARTRIDGE FUSE** – A fuse consisting of a current-responsive element inside a fuse body with contacts on both ends.

5.12 CIRCUIT BREAKER – A device designed to open and close a circuit by nonautomatic means, and to open the circuit automatically on a predetermined overcurrent without damage to itself when properly applied within its rating.

5.13 *Deleted*

5.14 CONTINUOUS DUTY – Operation at a substantially constant load for an indefinitely long time.

5.15 CURRENT-LIMITING DEVICE (AC) – An overcurrent protective device that, when interrupting currents in its current-limiting range, will reduce the current flowing in the faulted circuit to a magnitude substantially less than that obtainable in the same circuit if the device were replaced with a solid conductor having a comparable impedance.

5.16 CURRENT RATING – The designated maximum direct current or alternating current (RMS Amperes at rated frequency) that a device can carry continuously under specified conditions.

5.17 CUTOFF BOX – An enclosure designed for surface mounting that has swinging doors or covers secured directly to and telescoping with the walls of the enclosure.

5.18 DEADFRONT – A barrier that prevents live parts from being exposed to a person on the operating side of the panelboard.

5.19 DEADFRONT SHIELD – A barrier that is used behind a door to cover wiring spaces and uninsulated live parts that would otherwise be exposed to a person when the door is open.

5.20 DEVICE – A unit of an electrical system that is intended to carry or control, but not utilize, electrical energy.

5.21 DIELECTRIC WITHSTAND TESTS – Tests to determine the ability of the insulating materials and spacings to withstand overvoltages.

5.22 DOUBLE-LUG PANELBOARD – A panelboard that has two sets of main line terminals, each set having sufficient current-carrying capacity to supply the panelboard, see [Figure 5.1](#) and [Figure 5.2](#).

Figure 5.1

Subfeed lugs connected to incoming line terminals

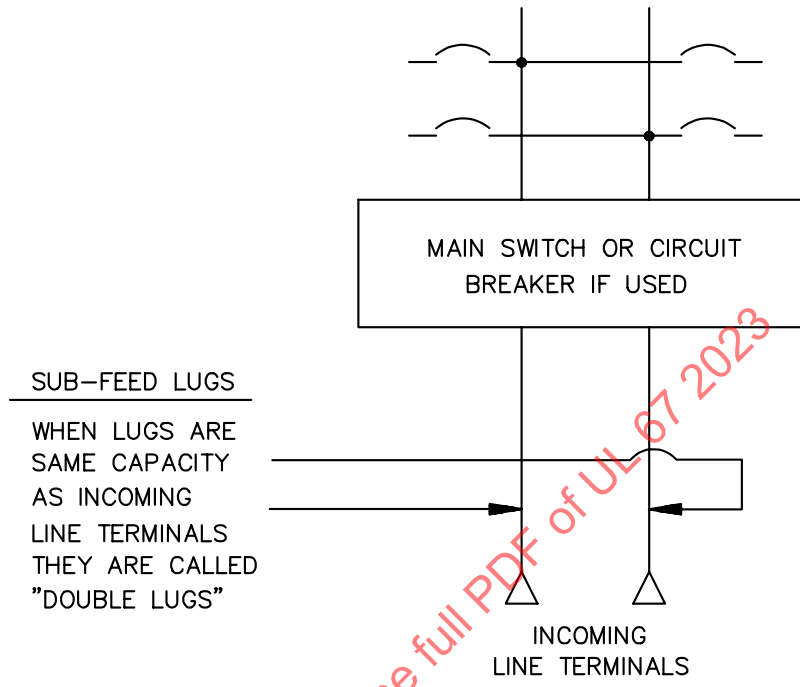

SM656

ULNORM.COM : Click to view the full PDF of UL 67 2023

Figure 5.2

Subfeed lugs connected to bus bars protected by an overcurrent protective device in the panelboard

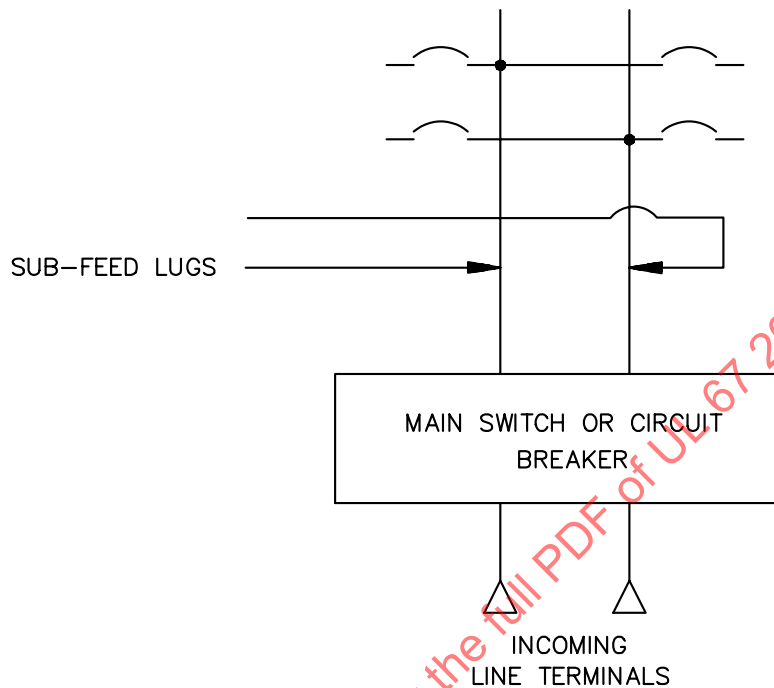

SM657

5.23 **DUMMY FUSE (TEST LINK)** – A current-carrying part made of copper and having dimensions such that it will fit its fuse-mounting means with the same conditions of pressure, contact, and cross-sectional areas as are obtained on terminals of the fuse that it is intended to replace. A dummy fuse shall not be a protective device.

5.24 **ENCLOSED PANELBOARD** – An assembly of buses and connections, overcurrent devices, and control apparatus with or without switches, or other equipment, installed in a suitable cabinet, cutout box, or enclosure suitable for a panelboard application.

5.25 **ENCLOSED RECREATIONAL VEHICLE (RV) PANELBOARD** – An enclosed panelboard intended to be installed in a recreational vehicle (RV) in accordance with Article 551 of the National Electrical Code, NFPA 70.

5.26 **ENCLOSURE** – A surrounding case constructed to provide a degree of protection to personnel against incidental contact with the enclosed equipment and to provide a degree of protection to the enclosed equipment against specified environmental conditions.

5.26A **ENERGY MANAGEMENT SYSTEM (EMS)** – A system that controls an electrical load, a power production source, or an energy storage system.

Note: A "Power Control System" is considered a type of Energy Management System.

5.27 **FEED-THROUGH LUG** – A terminal that is connected to a main bus bar at the end opposite from the incoming line terminal or main device, if used, and that is provided for connection to an outgoing wire or cable, see [Figure 5.3](#).

Figure 5.3

Feed through lugs for a separate circuit external to the panelboard

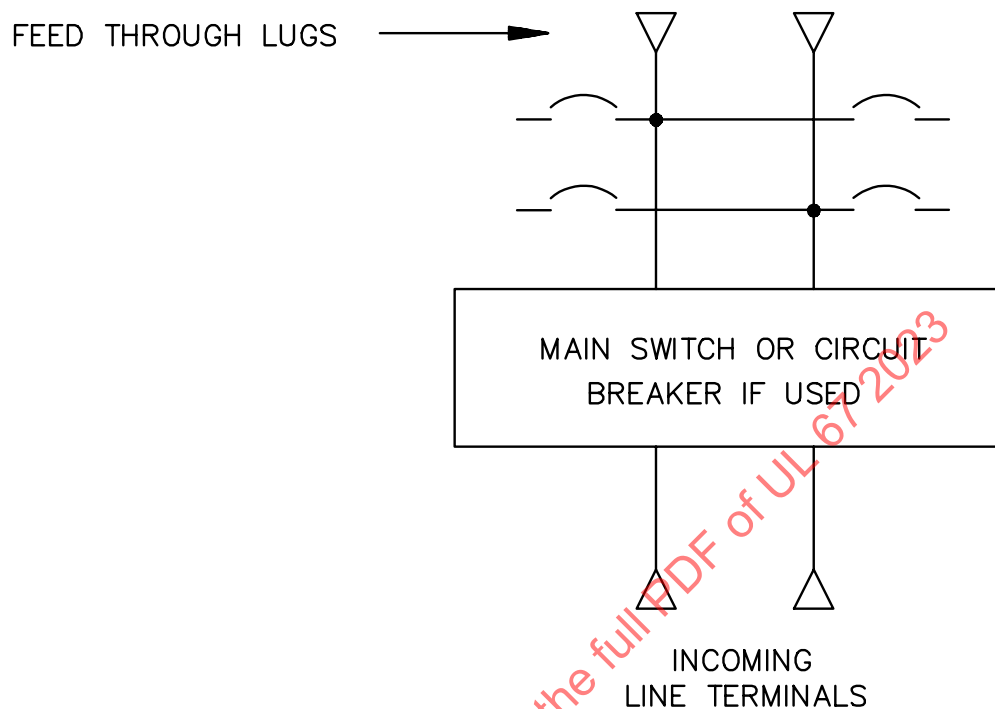

SM658

5.28 FILLER PLATE – A plate intended to close an opening that would otherwise be closed by the subsequent installation of a circuit breaker or other device.

5.29 FLUSH-MOUNTED (TYPE) – A device designed to be set into and secured to a flat surface, with a minimal front projection.

5.30 FRAME SIZE – A term applied to a group of molded case circuit breakers of similar physical configuration. Frame size is expressed in amperes and corresponds to the largest ampere rating available in the group. The same frame size designation may be applied to more than one group of circuit breakers.

5.31 FUSE – A non-resettable protective device which opens a circuit during specified overcurrent conditions by means of a current responsive element or elements.

5.32 FUSE CLIPS – The contacts of the fuseholder that support the fuse and connect the fuse terminals with the circuit.

5.33 FUSIBLE SWITCH – A switch in which one or more poles have a fuse in series in a composite unit.

5.34 FUSEHOLDER – An assembly of a base, fuse clips, and necessary insulation for the mounting and connecting of a fuse into a circuit.

5.35 GROUNDED CONDUCTOR – A system or circuit conductor that is intentionally grounded.

5.36 GROUND-FAULT CIRCUIT INTERRUPTER (GFCI) – A device intended for the protection of personnel that functions to de-energize a circuit or portion thereof within an established period of time when a current to ground exceeds the values established for a Class A device.

5.37 GROUND-FAULT PROTECTION OF EQUIPMENT – A system intended to provide protection of equipment from damaging line-to-ground fault currents by operating to cause a disconnecting means to open all ungrounded conductors of the faulted circuit. This protection is provided at current levels less than those required to protect conductors from damage through the operation of a supply circuit overcurrent device.

5.38 GUTTER TAP LUG – A terminal that is located in a wiring gutter of a panelboard and that is provided for:

- a) The connection of an incoming or an outgoing conductor, or a panelboard main, or
- b) The connection of two sets of outgoing conductors to a branch or other outgoing circuit, see [Figure 5.4](#) and [Figure 5.5](#).

A lug connecting an outgoing conductor is also considered to be a subfeed lug, see [5.61\(a\)](#).

Figure 5.4
Gutter tap lugs connected to panelboard mains

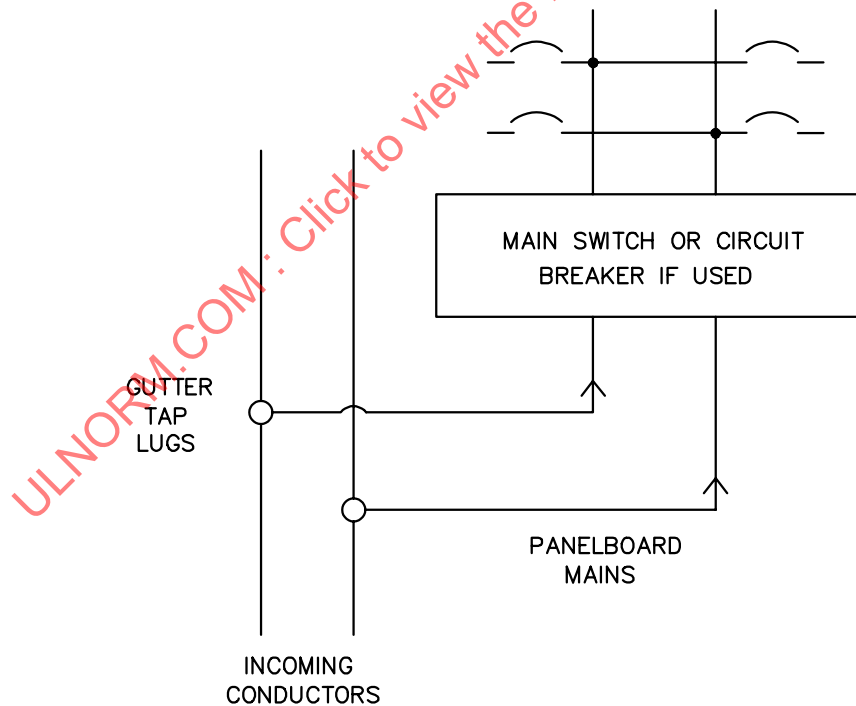

SM659

Figure 5.5

Gutter tap lugs connected to a branch circuit

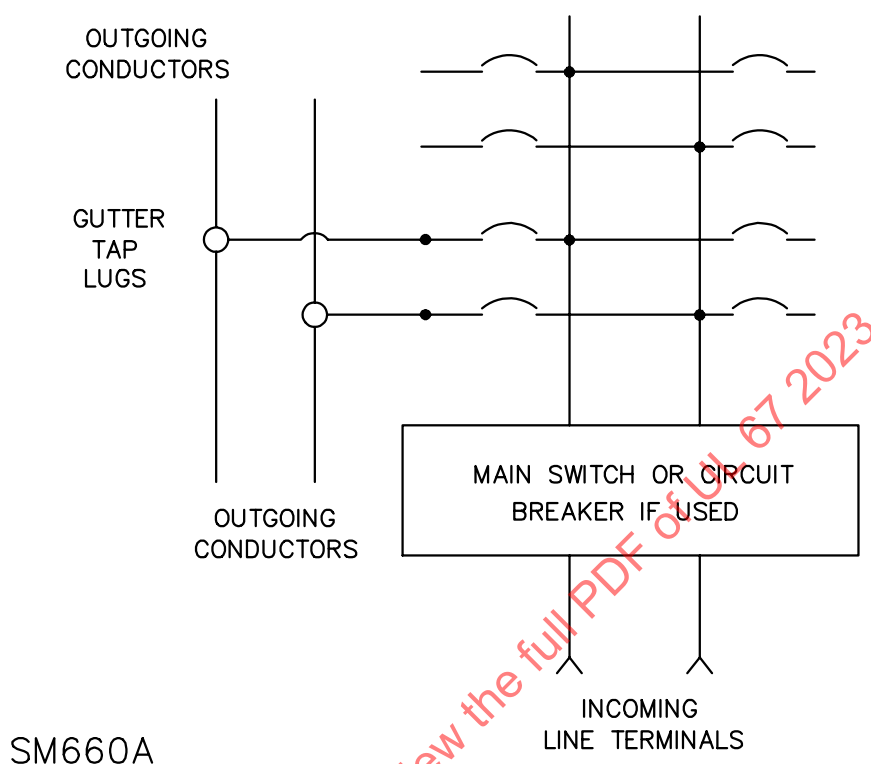

5.39 I^2t (AMPERE SQUARED SECONDS) – An expression related to the circuit energy as a result of current flow. " I^2t " is a common expression for the circuit energy between the initiation of the fault current and the clearing of the circuit. "I" is the value of current, expressed in amperes, and "t" is the duration of current flow, expressed in seconds. For AC applications, the value of current is to be the rms value.

5.40 INTERLOCK – An electrical or mechanical component actuated by the operation of a device with which it is directly associated to govern succeeding operations of the same or allied devices.

5.41 INTERRUPTING RATING – The highest current at rated voltage that a device is intended to interrupt under standard test conditions.

5.42 KNOCKOUT – A portion of the wall of an enclosure so fashioned that it is capable of being readily removed by a hammer, screw driver, and pliers at the time of installation in order to provide an opening or hole for the attachment of a raceway, cable, or fitting.

5.43 Deleted

5.44 LUG – A terminal that is provided for the connection of a wire or a cable to a panelboard or for a wire or cable connection between component parts of a panelboard.

5.45 MAIN – A device that is provided for the connection of a incoming line conductor.

5.46 MAIN TERMINAL – A terminal that is provided for the connection of an incoming line conductor.

5.47 MAINS (MAIN TERMINALS) – The terminals, or main device, provided for the connection of the main incoming line conductors.

5.48 NEUTRAL (ASSEMBLY); SOLID NEUTRAL – An assembly consisting of enough terminals to provide for the connection of the grounded (neutral) line and load conductors. When used as a component of service equipment, the neutral also includes the following:

- a) A means for making the required bonding connection between the neutral and the enclosure; and
- b) A terminal for the grounding electrode conductor.

5.49 NEUTRAL CONDUCTOR – A conductor that is connected to the midpoint of a three-wire single-phase system, the center point of a wye-connected three-phase system, or the midpoint of one side of a delta-connected three-phase system.

Note: The neutral conductor is the grounded conductor.

5.50 OVERCURRENT PROTECTIVE DEVICE – An individual fuse or circuit breaker pole.

5.51 PANELBOARD – A single panel or a group of panel units designed for assembly in the form of a single panel; includes buses, automatic overcurrent devices, and may be equipped with switches for the control of light, heat, or power circuits; designed to be placed in a cabinet or cutout box placed in or against a wall or partition and accessible only from the front.

5.52 PEAK LET-THROUGH CURRENT (AC) – The maximum instantaneous current through an overcurrent device during the total clearing time.

5.53 PLUG FUSE – A screw-in type fuse for use in an Edison base type fuseholder.

5.54 *Deleted*

5.55 PRESSURE WIRE CONNECTOR – A reusable connector into which the conductor (wire) is secured by mechanical pressure applied by an integral screw, cone, or other mechanical parts.

5.56 PULLOUT SWITCH – A switch, enclosed or nonenclosed, that is operated to open a circuit by manually separating the movable contact from the stationary contact, and is operated to close a circuit by manually reconnecting the movable contact and the stationary contact.

5.57 RATING – A designated limit of operating characteristics based on defined conditions.

5.58 SERVICE – The conductors and equipment for delivering electric energy from the serving utility to the wiring system of the premises served.

5.59 SERVICE EQUIPMENT – The necessary equipment, usually consisting of a circuit breaker(s) or switch(es) and fuse(s), and their accessories, connected to the load end of service conductors to a building or other structure, or an otherwise designated area, and intended to constitute the main control and cutoff of the supply.

5.60 SHORT-CIRCUIT CURRENT RATING (EQUIPMENT) – The maximum available current to which a device can be connected. The rating is expressed in amperes and volts. Ratings based on AC are rms values.

5.61 SUBFEED LUG – A terminal that is provided for the connection of a wire or a cable:

- a) To a bus bar that is connected directly to the panelboard main incoming line terminal, see [Figure 5.1](#); or
- b) To a bus bar fed by an overcurrent protective device in the panelboard, see [Figure 5.2](#).

5.62 SWITCH – A device, manually operated, unless otherwise designated, for opening and closing or for changing the connection of a circuit.

5.63 SYMMETRICAL CURRENT – Alternating current having no offset or transient component and, therefore, having a wave form essentially symmetrical about the zero axis. Symmetrical current is expressed in terms of rms A.

5.64 VENTILATED – So constructed as to provide a means to permit circulation of external air through the enclosure to remove excess heat, fumes, and vapors.

CONSTRUCTION

6 General

6.1 All panelboards

6.1.1 A panelboard shall employ materials throughout that are acceptable for the particular use, and shall be made and finished with the degree of uniformity and grade of workmanship practicable in a well-equipped factory.

6.2 Equipment on supply side of disconnect

6.2.1 Only the following equipment shall be permitted to be connected to the supply side of the service disconnecting means:

- a) Meters, meter sockets, or meter disconnect switches nominally rated not in excess of 1000 volts;
- b) Instrument transformers (current and potential), high-impedance shunts and Type 1 surge-protective devices;
- c) Load management devices if overcurrent protection is provided;
- d) Taps for load management devices, optional standby power systems, and fire and sprinkler alarms;
- e) Control circuits of power operable service disconnecting means including control circuits of optional standby power systems, if overcurrent protection and disconnecting means are provided; and
- f) Ground-fault protection systems or Type 2 surge-protective devices, if overcurrent protection and disconnecting means are provided.
- g) Interconnected electric power production sources, such as solar photovoltaic, wind, or fuel cell systems.

6.2.2 In determining the allowable number of service disconnects, a disconnecting means used solely for equipment installed on the supply side of the service disconnecting means shall not be counted.

6.2.3 Disconnects and overcurrent protection which are located on the supply side of the service disconnecting means, and:

- a) Are installed as part of the equipment; and
- b) The circuit being controlled is contained within the panelboard enclosure

may be located behind a deadfront or screwed-on cover that is only intended to be removed by a qualified person. See [34.9.10](#).

6.3 Distribution equipment

6.3.1 A panelboard may be designed for mounting on a mounting post or pedestal for distribution equipment.

6.4 Service equipment

6.4.1 A panelboard intended for use as service equipment, shall comply with the applicable requirements in the Reference Standard for Service Equipment, UL 869A.

6.4.2 Panelboards with provisions for only a single service disconnect shall be constructed such that, with the service disconnect in the off position, no ungrounded uninsulated live part is exposed to inadvertent contact by persons while servicing any field connected load terminal, including a neutral load terminal, a branch circuit equipment grounding terminal, or the neutral disconnect link. Exposure to inadvertent contact is determined by use of the probe illustrated in [Figure 6.1](#). If restriction to the line-side of the service disconnect is dependent on the installation of field installed service conductors, conductors sized in accordance with [12.1.10](#) shall be installed in the terminals when determining exposure to inadvertent contact. All live parts of the line side service terminal, including the connector body and pressure screw shall be evaluated.

NOTE: In accordance with the Standard for Electrical Safety in the Workplace, NFPA 70E, an electrically safe work condition should be established prior to working on electrical equipment. Accessibility requirements do not endorse working on energized electrical equipment.

ULNORM.COM : Click to view the full PDF of UL 67 2023

Figure 6.1
Straight probe

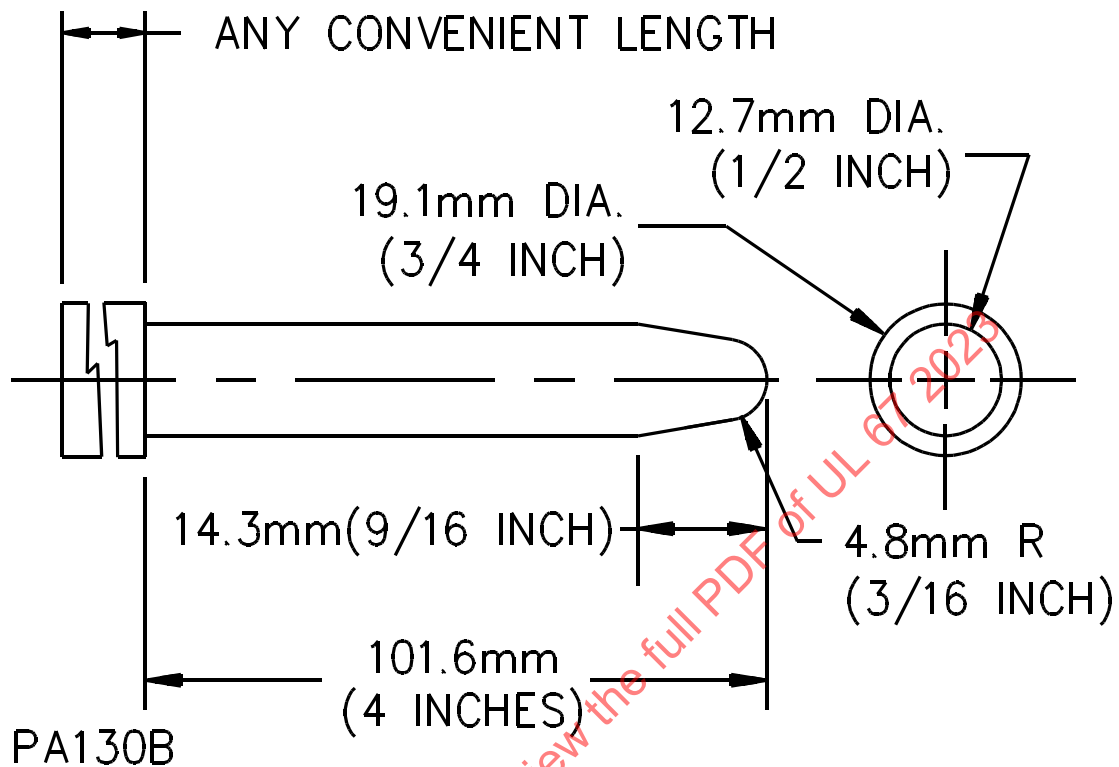

6.4.3 Metal barriers provided to limit exposure to inadvertent contact shall:

- a) Have a thickness not less than 0.032 inch (0.81 mm) if uncoated, not less than 0.034 inch (0.86 mm) if galvanized, and not less than 0.050 inch (1.27 mm) if aluminum.
- b) Be constructed so that it can be readily removed or repositioned, and then re-installed, without the likelihood of contacting bare live parts or damage the insulation of any insulated live part.

Exception: Factory installed barriers that limit access to factory installed wiring and terminations are not required to be constructed so that they can be removed or repositioned.

6.4.4 Nonmetallic barriers provided to limit exposure to inadvertent contact shall:

- a) Comply with requirements in [16.3.3](#) for barriers used in conjunction with a minimum air space of 0.013 inch (0.33 mm).
- b) Be constructed so that it can be readily removed or repositioned, and then re-installed, to allow access to the terminal for servicing.

Exception: Factory installed barriers that limit access to factory installed wiring and terminations are not required to be constructed so that they can be removed or repositioned.

6.4.5 Panelboards marked "Suitable for use as service equipment" and

- a) Constructed in accordance with [6.7.4](#) and designed for use interchangeably either with main-terminal or a single service disconnect only, or

b) Provided with a single service disconnect,

shall be permitted to provide the protection from inadvertent contact in [6.4.2](#) in a field installable kit when marked in accordance with [34.12.12](#). See also [34.9.11](#).

6.5 Branch circuits

6.5.1 A panelboard shall have more than one circuit subdivision. Terminals for a feed-through circuit are considered to be a circuit subdivision.

Exception: An enclosed panelboard having a meter socket may have only one load circuit.

6.5.2 Deleted

6.5.3 Deleted

6.5.4 Deleted

6.5.5 Deleted

6.6 Electrical connections

6.6.1 Other than as noted in [6.6.2](#) and [6.6.3](#), all electrical connections between switches, fuseholders, circuit breakers, and the like shall be complete so that only line, load, metering, and control circuits need be connected when a panelboard is installed.

6.6.2 Deleted

6.6.3 A panelboard may be shipped from the factory without branch-circuit bus bars mounted in place. A barrier that is needed to comply with the spacing requirements in Section [16](#), Spacings, is to be permanently attached to the panelboard or the field-installed branch-circuit bus bars. See [11.2.7](#) and [34.12.4](#).

6.6.4 A panelboard shall be constructed so that any component intended to be field installed can be installed without the use of a special tool.

6.6.5 With reference to [6.6.4](#), if a panelboard is acceptable for use with or without a neutral bus bar, the neutral bus bar need not be mounted in place when the panelboard is shipped from the factory if:

- a) The panelboard and the neutral bus bar are marked in accordance with [34.12.6](#);
- b) The neutral bus bar is shipped completely assembled so that field assembly of barriers or other parts, other than terminals or the mounting of a separate cover after the neutral is wired in the field, is not necessary.

6.6.6 With reference to [6.6.4](#), separate wires or bus bars may be provided for making the connection:

- a) To or from a fusible switch or circuit breaker that will control a section of a panelboard, or
- b) To associated equipment.

One end of such a wire or bus bar may be connected in place when the panelboard is shipped from the factory. See [11.2.4](#) and [34.12.10](#).

6.6.7 If one end of the separate wire mentioned in [6.6.6](#) is not connected when the panelboard is shipped, the loose end shall be secured so that damage to itself and to the panelboard during shipment is not likely to occur. If the load end of the wire is not connected to the panelboard when shipped, it shall be:

- a) Secured to an insulating base that is acceptable for supporting uninsulated live parts, or
- b) Completely covered, including the cut end, with acceptable insulation.

6.6.8 A back-fed unit – such as a circuit breaker, a fused switch, or a main terminal kit – that uses a friction or plug-on bus bar connection shall not be used to terminate the field installed ungrounded supply conductors.

Exception: A back-fed unit provided with an additional fastener that requires other than a pull to release the unit from its mounting position on the panel (such as a hold-down kit for a back-fed main circuit breaker) may be used to terminate field installed ungrounded supply conductors. See [34.1.17](#) and [34.12.1](#).

6.6.9 Panelboards for use in accordance with Article 702 of the National Electrical Code, ANSI/NFPA 70, shall have both main disconnect units comply with [6.6.8](#) or its exception.

6.6.10 The operating mechanism in a panelboard used as transfer equipment in accordance with Article 702 of the National Electrical Code, ANSI/NFPA 70, shall be interlocked to prevent simultaneous connection to both the normal and alternate sources of supply. The interlock shall be installed as part of the panelboard assembly in the factory or provisions made for its field installation. The panelboard or field installed kit shall be marked in accordance with [34.12.18](#) or [34.12.19](#).

6.6.11 Panelboards intended for interconnection with one or more electric power production sources operating in parallel with a primary source(s) of electricity, in accordance with Article 705 of the National Electrical Code, NFPA 70, shall be permitted to have provisions for connection(s) as noted in (a) and (b). See [34.16](#) for marking requirements.

a) Supply Side Connection – Panelboards intended for use in applications where the non-primary sources are connected on the supply side of the service disconnecting means, see [6.2.1\(g\)](#), shall comply with the following:

1) The current rating of the panelboard or ampacity of the bus bars (see [31.1](#)) shall not be exceeded based on the sum of sources being determined by one of the following methods:

- i) The sum of the continuous current output ratings of all supply side overcurrent devices connected to non-primary parallel power sources.
- ii) The sum of all connected non-primary parallel power sources is limited by the current setpoint of an EMS complying with [6.6.12](#).

2) If connections are provided to interconnect power production sources, those connections shall accommodate conductors no smaller than 6 AWG copper or 4 AWG aluminum.

b) Load Side Connection – Panelboards intended for use in applications where the non-primary sources are connected on the load side of the service disconnecting means shall be permitted to have one or more load side disconnects for the interconnection of parallel power sources if the current rating of the panelboard or ampacity of the bus bars (see [31.1](#)) is not exceeded, based on the sum of source and/or loads that can be simultaneously energized, as determined by one of the following methods:

1) The sum of the continuous current output ratings of all overcurrent devices connected to primary and non-primary parallel power sources

- 2) The sum of all connected loads that can be simultaneously energized, or primary and non-primary parallel power sources, is limited by the current setpoint of an EMS complying with [6.6.12](#)

Exception: The total rating of all overcurrent devices supplying the panelboard may exceed the rating of the panelboard by up to 120% of the rating of the panelboard if the overcurrent device(s) intended for use with interconnected parallel power sources are positioned at the opposite end from the main input, or if the connections are at either end of a center-fed panelboard.

6.6.12 An Energy Management System or components of an EMS may be installed, or instructions to install an EMS may be specified, to control the sources or loads to be connected to the panelboard. EMS that control sources shall comply with the Standard for Inverters, Converters, Controllers and Interconnection System Equipment for Use With Distributed Energy Resources, UL 1741. EMS that control loads shall comply with the Standard for Energy Management Systems, UL 916, and Supplement SA for Safety of Smart Enabled Energy Management Equipment or the requirements for Class B control functions in the Standard for Automatic Electrical Controls – Part 1: General Requirements, UL 60730-1. Markings, as specified in [34.16.7](#), shall be provided when a panelboard includes an EMS, components of an EMS, or instructions to install an EMS.

6.6.13 Panelboards intended to provide uninterruptible power supply to control circuitry shall be marked in accordance with [34.17.1](#).

6.7 Field installable equipment

6.7.1 Field Installable equipment shall comply with all applicable requirements of this standard.

6.7.2 A panelboard may have provision for field-installed accessories provided the following conditions are met:

- a) The panelboard is acceptable for use with or without the accessory.
- b) Instructions for the installation and operation are provided with each accessory.
- c) The installation of an accessory does not require the use of other than normally available tools, such as screwdrivers, pliers and wrenches, unless such a tool and instructions for its use are furnished with each accessory.
- d) A barrier that is necessary because spacings would otherwise be less than required is securely attached at the factory to either the panelboard, or to the accessory to be installed.
- e) The accessory is an essentially complete unit and does not require assembly in the field.
- f) The installation of the accessory does not expose uninsulated or mechanical functional parts that would not be exposed during the replacement of overcurrent protective devices.
- g) Except as noted in (h) and (i) means for mounting the accessory require no drilling, cutting, or filing of holes.
- h) Drilling, cutting, or filing is acceptable in the panelboard enclosure if such openings are indicated by drill points or breakouts on the enclosure. Drill points may be applied at the factory, by a template provided with the field-installed accessory, or other equivalent means, such that the location to be drilled can be determined by the installer.
- i) It is possible to accomplish the operation described in (h) in a manner so that debris inside the panelboard enclosure does not accumulate.
- j) The accessory complies with the marking requirements of [34.12](#), Field-installed equipment.

6.7.3 Pressure terminal connectors for line or load field connections that are available from the equipment manufacturer in the form of a field installable terminal kit, or as one or more terminal connectors specified for field installation on the equipment, shall comply with the following (reference [12.1.1](#), Exception No. 2):

- a) Fastening devices, such as studs, nuts, bolts, spring and flat washers, as required for an effective installation shall either be provided as part of the component terminal kit or be mounted on or separately packaged with the equipment.
- b) The installation of the terminal kit shall not involve the loosening or disassembly of parts other than a cover or other part giving access to the terminal location. The means for securing the terminal connector shall be readily accessible for tightening before and after installation of conductors.
- c) If the pressure terminal connector specified in (a) requires the use of a special tool for securing the conductor, any necessary instructions shall be included in the component terminal kit package or with the equipment.
- d) Installation of the pressure terminal connectors in the intended manner shall result in a product that meets the requirements in this standard.
- e) The equipment shall be marked in accordance with [34.12](#), Field-installed equipment.

6.7.4 The main terminals may be in the form of a main-terminal kit if the panelboard is specifically designed for use interchangeably either with those terminals or with a main circuit breaker or switch. A main-terminal kit may consist of individual terminals or may be an assembly consisting of:

- a) Terminals;
- b) Bus bars that provide connections between those terminals and the main bus bars of the panelboard; and
- c) A mounting means for those components.

The kit may be connected to the main bus bars by either bolting or plugging in. See [34.12.11](#).

7 Enclosure

7.1 General

7.1.1 A panelboard shall be constructed for use in a switchboard, cabinet, or cutout box. An enclosed panelboard shall be provided with an enclosure complying with the Standard for Enclosures for Electrical Equipment, Non-Environmental Considerations, UL 50, except for modification and additional requirements as specifically described in the standard.

7.1.2 A single-threaded nut designed to slip over the edge of sheet metal to receive a retaining screw may be used to secure a deadfront to supports, a unit such as a switch or circuit breaker to a mounting panel, a mounting pan to an enclosure, or a cover or a front to an enclosure if:

- a) The nut is protected against corrosion by enameling, galvanizing, sherardizing, plating, or other equivalent means.
- b) The threads do not strip when a torque of 30 pound-inches (3.4 N·m) is applied.

7.1.3 A Panelboard enclosure shall be sufficiently deep to allow the door or doors to be closed with any switches in either the open or the closed position.

7.1.3.1 The enclosure shall be constructed so that all doors accessing equipment that is likely to require examination, adjustment, servicing, or maintenance while energized shall open to a minimum of 90 degrees from the closed position.

7.1.4 An enclosed panelboard having provision for mounting a meter may have an opening to accommodate a watt-hour meter.

7.1.5 An opening for a watt-hour meter as mentioned in [7.1.4](#) and the metal from which it is cut shall comply with the Standard for Meter Sockets, UL 414.

7.1.6 For enclosed recreation vehicle (RV) panelboards, that portion of the enclosure associated with the low voltage compartment, may comply with the enclosure requirements in the Standard for Power Converters/Inverters and Power Converter/Inverter Systems for Land Vehicles and Marine Crafts, UL 458. Unless the line voltage and low voltage compartment of the assembly are separated by a barrier that complies with enclosure requirements in the Standard for Enclosures for Electrical Equipment, Non-Environmental Considerations, UL 50, the overall assembly shall be mounted in an enclosure which complies with the requirements of UL 50.

7.2 Component arrangement

7.2.1 A fuse puller and a pull-out switch incorporating a fuseholder employed in a panelboard shall have no live parts exposed when the device is in the closed position, and cartridge-fuse clips in such a device shall be dead when accessible for the inspection or replacement of fuses.

7.2.2 The setting, adjustment, or manual operation of a clock-operated switch or similar device by an operator shall not result in exposure of wiring, other than that directly connected to the switch or device, or exposure to unintentional contact with live parts.

7.2.3 A meter-socket base shall be mounted independently of the cover unless it is intended to be used with a current transformer.

7.2.4 The enclosure of a meter socket shall house completely all live parts with an appropriate meter mounted in position.

7.2.5 In a meter socket, all bare live parts shall be recessed:

- a) Not less than 1/2 inch (12.7 mm) behind the plane of the outer edge of the meter-mounting rim, or behind the plane of the meter-mounting hole if a mounting rim is not provided.
- b) Behind the plane of the cover, unless a barrier or the like is provided so that the cover may be removed without the likelihood of its contacting a bare live part.

7.3 Ventilating openings

7.3.1 General

7.3.1.1 Ventilating openings shall only be permitted on enclosed panelboards rated 400 amperes or more. When provided, ventilating openings shall be located as follows:

- a) In an enclosure intended for surface mounting only – permitted in the front, side, top or bottom walls only,
- b) In an enclosure not intended for surface mounting only – permitted in the front only.