



UL 498

STANDARD FOR SAFETY

Attachment Plugs and Receptacles

ULNORM.COM : Click to view the full PDF of UL 498 2024

ULNORM.COM : Click to view the full PDF of UL 498 2024

UL Standard for Safety for Attachment Plugs and Receptacles, UL 498

Sixteenth Edition, Dated April 28, 2017

SUMMARY OF TOPICS

This revision of ANSI/UL 498 dated June 20, 2024 includes the following changes in requirements:

- ***Clarification of requirements for receptacle grounding terminal; [29.1.4](#)***
- ***15 & 20 A Receptacle Conductor Markings; [12.6.2](#), [30.8.1](#), [Table 59.4](#), [123.1](#), [123.5](#), [Table 193.4](#), [193.1.6A](#), [Figure 193.1](#), and [Figure 193.1A](#)***
- ***Revision to [Table 193.4](#)***
- ***Editorial error: PLASA reference in [7.2](#)***

Text that has been changed in any manner or impacted by ULSE's electronic publishing system is marked with a vertical line in the margin.

The new and revised requirements are substantially in accordance with Proposal(s) on this subject dated April 7, 2023, September 29, 2023 and March 22, 2024.

All rights reserved. No part of this publication may be reproduced, stored in a retrieval system, or transmitted in any form by any means, electronic, mechanical photocopying, recording, or otherwise without prior permission of ULSE Inc. (ULSE).

ULSE provides this Standard "as is" without warranty of any kind, either expressed or implied, including but not limited to, the implied warranties of merchantability or fitness for any purpose.

In no event will ULSE be liable for any special, incidental, consequential, indirect or similar damages, including loss of profits, lost savings, loss of data, or any other damages arising out of the use of or the inability to use this Standard, even if ULSE or an authorized ULSE representative has been advised of the possibility of such damage. In no event shall ULSE's liability for any damage ever exceed the price paid for this Standard, regardless of the form of the claim.

Users of the electronic versions of UL's Standards for Safety agree to defend, indemnify, and hold ULSE harmless from and against any loss, expense, liability, damage, claim, or judgment (including reasonable attorney's fees) resulting from any error or deviation introduced while purchaser is storing an electronic Standard on the purchaser's computer system.

No Text on This Page

ULNORM.COM : Click to view the full PDF of UL 498 2024

APRIL 28, 2017
(Title Page Reprinted: June 20, 2024)



ANSI/UL 498-2024

1

UL 498

Standard for Attachment Plugs and Receptacles

Fifth Edition – September, 1952
Sixth Edition – November, 1954
Seventh Edition – December, 1959
Eighth Edition – May, 1962
Ninth Edition – April, 1974
Tenth Edition – September, 1981
Eleventh Edition – November, 1986
Twelfth Edition – April, 1991
Thirteenth Edition – April, 1996
Fourteenth Edition – December, 2001
Fifteenth Edition – March, 2012

Sixteenth Edition

April 28, 2017

This ANSI/UL Standard for Safety consists of the Sixteenth Edition including revisions through June 20, 2024.

The most recent designation of ANSI/UL 498 as an American National Standard (ANSI) occurred on June 20, 2024. ANSI approval for a standard does not include the Cover Page, Transmittal Pages, and Title Page.

The Department of Defense (DoD) has adopted UL 498 on August 17, 1981. The publication of revised pages or a new edition of this Standard will not invalidate the DoD adoption.

Comments or proposals for revisions on any part of the Standard may be submitted to ULSE at any time. Proposals should be submitted via a Proposal Request in the Collaborative Standards Development System (CSDS) at <https://csds.ul.com>.

Our Standards for Safety are copyrighted by ULSE Inc. Neither a printed nor electronic copy of a Standard should be altered in any way. All of our Standards and all copyrights, ownerships, and rights regarding those Standards shall remain the sole and exclusive property of ULSE Inc.

COPYRIGHT © 2024 ULSE INC. ALL RIGHTS RESERVED.

No Text on This Page

ULNORM.COM : Click to view the full PDF of UL 498 2024

CONTENTS

INTRODUCTION

1	Scope	15
2	Glossary	16
3	Components	19
4	Units of Measurement	20
5	References	20

CONSTRUCTION

ALL DEVICES

6	General	20
7	Configurations	20
8	Insulating Materials	20
	8.1 General	20
	8.2 Flammability	21
	8.3 Electrical properties	21
	8.4 Thermal properties	22
	8.5 Vulcanized fiber	23
	8.6 Sealing compounds	23
	8.7 Fuse enclosures	23
9	Enclosure	24
	9.1 General	24
	9.2 Male faces and wire terminations	26
10	Current-Carrying Parts	27
	10.1 General	27
	10.2 Contacts	27
11	Grounding and Dead Metal Parts	28
12	Terminals	29
	12.1 General	29
	12.2 Wire-binding screw terminals	30
	12.3 Soldering lugs	30
	12.4 Pressure-wire terminals	31
	12.5 Combination wire binding/pressure-wire terminals	31
	12.6 Spring action clamp terminals	31
	12.7 Attachment fitting	32
13	Cord Entry and Strain Relief	33
14	Spacings	33
15	Assembly	34
	15.1 General	34
	15.2 Grounding and polarization	34
	15.3 Mating and interchangeability	35
	15.4 Fuseholders	36
	15.5 Switches	37

ATTACHMENT PLUGS AND INLETS

16	Insulating Materials	37
17	Enclosure	37
	17.1 General	37
	17.2 Grip	38
	17.3 Face size	38

17.4	Configurable Plug	38
18	Current-Carrying Parts.....	39
19	Grounding and Dead Metal Parts.....	40
20	Terminals and Leads	41
20.1	Terminals	41
20.2	Leads	42
20.3	Attachment plug and inlet with spring action clamp terminal	42
21	Assembly.....	42
22	Weatherproof Type.....	45

CORD CONNECTORS

23	Enclosure	45
23.1	General.....	45
23.2	Face size	46
24	Grounding and Dead Metal Parts.....	49
25	Terminals.....	49
25A	Cord Connector with Spring Action Clamp Terminal	49
26	Assembly.....	49
26.1	General.....	49
26.2	Outlet separation	50

RECEPTACLES

26A	General.....	50
27	Insulating Materials	50
28	Enclosure	50
29	Grounding and Dead Metal Parts.....	51
29.1	General.....	51
29.2	Flush receptacles	52
30	Terminals and Leads	52
30.1	General.....	52
30.2	Push-in terminals.....	53
30.3	Pin-type or insulation-displacement terminals	53
30.4	Open wiring on insulators	53
30.5	Leads	53
30.6	Separable terminal assembly.....	54
30.7	Receptacle with spring action clamp terminal.....	54
30.8	Receptacles intended for copper-clad aluminum conductor.....	55
31	Assembly.....	55
31.1	General.....	55
31.2	Flush receptacles	55
31.3	Surface-mount receptacles.....	57
32	Flush Plates.....	57
33	Self-Grounding Receptacles	57
34	Isolated-Ground Receptacles	57
35	CO/ALR Type.....	58
36	AL-CU Type	58
37	Tamper-Resistant Receptacles.....	58
38	Weather-Resistant Receptacles	58
39	Pendant Receptacles	58
40	Pop-Out Receptacle	59
41	Pop-Up Receptacle Assembly	59
42	Rotatable Outlets	59
42A	Lighted Receptacle	59

42B Luminaire or Fan Support Receptacle59
42C Ceiling-Suspended Fan Test60
42D Receptacle Installation Instructions60

SELF-CONTAINED RECEPTACLES FOR USE WITHOUT A SEPARATE OUTLET BOX

43 General61
44 Spacings61
45 Insulating Materials61
46 Enclosures.....61
47 Mounting Means62
48 Frame-Construction Mounting Brackets62
49 Field Replacement63

CURRENT TAPS

50 General63

FLATIRON AND APPLIANCE PLUGS

51 General64
52 Current-Carrying Parts.....64
53 Cord Guard.....64
54 Strain Relief64
55 Female Contacts64
56 Terminals65
57 Spacings65
58 Assembly.....66

PERFORMANCE

GENERAL

59 Representative Devices.....66

ALL DEVICES

60 Comparative Tracking Index Test.....75
61 Glow Wire Test.....75
62 High-Current Arc Resistance to Ignition Test.....76
63 Mold Stress Relief Test77
64 Moisture Absorption Resistance Test77
65 Dielectric Voltage-Withstand Test78
 65.1 Devices for fixed or permanent installation78
 65.2 Cord-connected devices.....79
66 Accelerated Aging Tests79
 66.1 General.....79
 66.2 Rubber, EPDM, and TEE compounds.....79
 66.3 PVC compounds and copolymers79
67 Insulation Resistance Test80
68 Conductor Secureness Test80
69 Tightening Torque Test.....81

ATTACHMENT PLUGS

WORM.COM : Click to view the full PDF of UL 498 2024

ALL DEVICES

70	General	81
71	Security of Blades Test	81
	71.1 General.....	81
	71.2 Self-hinged plugs.....	81
72	Secureness-Of-Cover Test.....	82
73	Crushing Test.....	82
74	Attachment Plug Grip Tests	82
75	Integrity of Assembly Test	85
	75.1 General.....	85
	75.2 Self-hinged plugs.....	86
76	Self-Hinge Flexing Test.....	86
77	Terminal Temperature Test.....	86
77A	Spring Action Clamp Terminal Pull Test.....	87
78	Fuseholder Temperature Test.....	88

PIN-TYPE TERMINALS

79	General	89
80	Assembly Test.....	89
81	Temperature Test	89
82	Strain Relief Test	90
83	Fault Current Test.....	90
84	Dielectric Voltage-Withstand Test	91

INLETS**ALL DEVICES**

85	General	92
86	Security of Blades Test	92
87	Terminal Temperature Test.....	92
88	Fuseholder Temperature Test.....	93

PRESSURE-WIRE TERMINALS

89	General	94
90	Combination Wire Binding/Pressure Wire-Type Terminals	95
91	Strength of Insulating Base Test	95
91A	Spring Action Clamp Terminal Pull Test.....	96

CORD CONNECTORS**ALL DEVICES**

92	General	97
93	Retention of Plugs Tests	97
94	Overload Tests.....	97
	94.1 General.....	97
	94.2 Current overload test	99
	94.3 Horsepower overload test.....	99

95	Temperature Test	103
96	Retention of Plugs Test (Repeated).....	104
	96.1 General.....	104
	96.2 Plug retention	105
	96.3 Plug withdrawal	105
97	Resistance to Arcing Test.....	106
98	Latching Mechanism Tests	106
	98.1 General.....	106
	98.2 Cycling test	106
	98.3 Pull test.....	106
99	Fuseholder Temperature Test.....	107
99A	Spring Action Clamp Terminal Pull Test.....	108
100	Improper Insertion Test	109
101	Potential Drop in Grounding Connections Test.....	110
102	Integrity of Assembly Test	111
	102.1 General.....	111
	102.2 Self-hinged cord connectors	111
103	Self-Hinge Flexing Test	111

PIN-TYPE TERMINALS

104	General	112
105	Assembly Test.....	112
106	Temperature Test	112
107	Strain Relief Test	113
108	Fault Current Test.....	113
109	Dielectric Voltage-Withstand Test.....	114

RECEPTACLES

ALL DEVICES

110	General.....	114
111	Retention of Blades Test.....	115
112	Overload Test	121
113	Temperature Test.....	122
114	Retention of Blades Test (Repeated).....	123
115	Resistance to Arcing Test	124
116	Retention of Plugs Test	124
117	Overload Test.....	125
	117.1 General	125
	117.2 Current overload test.....	126
	117.3 Horsepower overload test	127
118	Temperature Test.....	131
	118.1 Contact and terminal temperature	131
	118.2 Feed-through terminal temperature	133
119	Retention of Plugs Test (Repeated).....	133
	119.1 General	133
	119.2 Plug retention	133
	119.3 Plug withdrawal.....	134
120	Resistance to Arcing Test.....	134
121	Fuseholder Temperature Test	135
122	Fault Current Test.....	136
123	Terminal Strength Test	136

124	Assembly Security Test	140
125	Grounding Contact Test	146

PRESSURE-WIRE TERMINALS

126	General	150
127	Combination Wire Binding/Pressure Wire-Type Terminals	152
128	Strength of Insulating Base Test	152
128A	Spring Action Clamp Terminal Pull Test	152

SELF-GROUNDING RECEPTACLES

129	General	153
130	Fault Current Test	153

PUSH-IN TERMINALS

131	General	156
132	Pullout Test	156
133	Temperature Test	156
134	Conductor Insertion and Retention Test	157
135	Conductor Push-In Test	157
136	Terminal Abuse Test	158
137	Temperature Test	160

TAMPER-RESISTANT RECEPTACLES

138	General	164
139	Probe Test	164
140	Impact Test	166
	140.1 General	166
	140.2 Ball-pendulum impact	166
	140.3 Vertical-ball impact	169
141	Mechanical Endurance Test	172
142	Dielectric Voltage-Withstand Test	172

RECEPTACLE WITH INTEGRAL ADJUSTABLE MOUNTING YOKE

143	Bonding (Non-Metallic Outlet Box Fault Current) Test	172
144	Bonding (Metallic Outlet Box Fault Current) Test	175
145	Mounting Yoke Resistance Test	176

POP-OUT RECEPTACLES AND POP-UP RECEPTACLE ASSEMBLIES

146	General	176
	146.1 Pop-out receptacles	176
	146.2 Pop-up receptacle assemblies	176
147	Mechanical Endurance Test	176
148	Mechanical Load Test	177
149	Spill Test	177

PIN-TYPE OR INSULATION-DISPLACEMENT TERMINALS

150	General	178
-----	---------------	-----

151	Heat Cycling and Vibration Tests	178
151.1	General.....	178
151.2	Heat cycling test	178
151.3	Vibration test	179
151.4	Heat cycling test (Continued)	179
151.5	Calculations	179

RECEPTACLES EMPLOYING A SEPARABLE TERMINAL ASSEMBLY

152	General	179
153	Retention of Tab Connection Test	180
154	Separable Connector Pull Test	180
155	Mold Stress Relief Test	180
156	Dielectric Voltage-Withstand Test.....	180
157	Grounding Contact Temperature Test.....	181
158	Resistance Test.....	181
159	Latching Mechanism Test.....	182
160	Short Circuit Test	182
161	Continuity Impedance Test	182

RECEPTACLES EMPLOYING ROTATABLE OUTLETS

162	General	183
163	Rotational Endurance Test	183
164	Temperature Test	183
165	Dielectric Voltage-Withstand Test.....	183
166	Resistance Test.....	183
167	Fault Current Test.....	183

SELF-CONTAINED RECEPTACLES

168	General	184
169	Heat Cycling and Vibration Tests	184
169.1	General.....	184
169.2	Heat cycling test	184
169.3	Vibration test	185
169.4	Calculations	185
170	Cable Pullout Test	186
171	Conductor Pullout Test.....	186
172	Mounting Strength Test.....	186
172.1	General.....	186
172.2	Receptacles mounted directly in panels.....	186
172.3	Receptacles supported by mounting brackets	187
172.4	Testing	187
173	Wall-Mounting Secureness Test.....	187
174	Assembly Security Test.....	190
174.1	General.....	190
174.2	Method A	190
174.3	Method B	191
175	Field Replacement Test.....	191
176	Fault Current Withstand Test	191
177	Knockouts Test.....	192
178	Creep Test	192
179	Mold Stress Test.....	192
180	Specimen Flammability Test.....	193

180.1	General.....	193
180.2	Method A	193
180.3	Method B	193

CURRENT TAPS

ALL DEVICES

181	General	193
182	Contact Security Test.....	193

FLATIRON AND APPLIANCE PLUGS

183	General	194
184	Millivolt Drop Test	194
185	Overload Test.....	194
186	Heating Test.....	195
187	Millivolt Drop Test Repeated	195
188	Crushing Test.....	195
189	Mechanical Endurance Test	195
190	Accelerated Aging Test	198
191	Cord Guard Test.....	198

RATINGS

192	Details	200
-----	---------------	-----

MARKINGS AND INSTRUCTIONS

193	General	204
	193.1 Details	204
	193.2 Location of markings and instructions	225
194	Identification and Marking of Terminals.....	226
	194.1 Grounded and grounding.....	226
	194.2 Other terminals.....	229
	194.3 Removable parts	229

SUPPLEMENT SA – ENCLOSURE TYPES FOR ENVIRONMENTAL PROTECTION

INTRODUCTION

SA1	Scope	231
SA2	Glossary	231

CONSTRUCTION

SA3	General.....	231
SA4	Polymeric Enclosures	232
SA5	Gaskets	233

PERFORMANCE

SA6	General.....	233
-----	--------------	-----

MARKINGS

SA7 General..... 237

SUPPLEMENT SB – MARINE SHORE POWER INLETS

INTRODUCTION

SB1 Scope..... 239
SB2 Glossary..... 239
SB3 General..... 239

CONSTRUCTION

SB4 General..... 239
SB5 Insulating Materials..... 241
SB6 Corrosion Resistance..... 241

PERFORMANCE

SB7 General..... 242
SB8 Salt-Spray Test..... 242
SB9 Dielectric Voltage-Withstand Test..... 242
SB10 Mechanical Strength Test..... 242
SB11 Water-Spray Test..... 244
SB12 Shock Test..... 247

SUPPLEMENT SC – HOSPITAL GRADE DEVICES

INTRODUCTION

SC1 Scope..... 249

CONSTRUCTION

SC2 General..... 249

PERFORMANCE

GENERAL

SC3 Representative Devices..... 250

HOSPITAL GRADE ATTACHMENT PLUGS

SC4 General..... 251
SC5 Strain Relief Tests..... 252
SC5.1 General..... 252
SC5.2 Method A – static pull..... 252
SC5.3 Method B – rotary pull..... 252
SC5.4 Method C – abrupt removal..... 252
SC5.5 Straight attachment plugs..... 256
SC5.6 Angle attachment plugs..... 256
SC6 Crushing Test..... 256

ULNORM.COM : Click to view the full PDF of UL 498 2024

SC7	Impact Resistance Test	256
SC8	Mechanical Drop Test	257
SC9	Mold Stress Relief Test	258

HOSPITAL GRADE CORD CONNECTORS

SC10	General	258
SC11	Grounding Contact Temperature Test	258
SC12	Resistance Test	258
SC13	Grounding Contact Overstress Test	259
SC14	Plug Connection and Separation Test	263
SC15	Crushing Test	263
SC16	Impact Resistance Test	263
SC17	Mechanical Drop Test	264
SC18	Mold Stress Relief Test	266
SC19	Strain Relief Tests	266
SC19.1	General	266
SC19.2	Method A – static pull	266
SC19.3	Method B – rotary pull	266
SC19.4	Method C – abrupt removal	267

HOSPITAL GRADE RECEPTACLES

SC20	General	270
SC21	Abrupt Plug Removal Test	270
SC22	Grounding Contact Temperature Test	274
SC23	Resistance Test	274
SC24	Fault Current Test	275
SC25	Grounding Contact Overstress Test	275
SC26	Terminal Strength Test	277
SC27	Assembly Security Test	277
SC28	Impact Test	277
SC29	Mold Stress Relief Test	277

MARKINGS

SC30	General	277
------	---------------	-----

SUPPLEMENT SD – WEATHER-RESISTANT RECEPTACLES

INTRODUCTION

SD1	Scope	279
-----	-------------	-----

CONSTRUCTION

SD2	General	279
SD3	Insulating Materials	279
SD4	Corrosion Resistance	279

PERFORMANCE

SD5	General	280
SD6	Cold Impact Test	280

SD7	Accelerated Aging Test	281
SD8	Ultraviolet Light and Water Exposure Test	281

MARKINGS

SD9	General	282
-----	---------------	-----

SUPPLEMENT SE – RECEPTACLES WITH INTEGRAL POWER SUPPLY WITH CLASS 2 OUTPUT CONNECTORS

INTRODUCTION

SE1	Scope	283
SE2	Glossary	283

CONSTRUCTION

SE3	General	284
SE4	Separable Face Assembly	284
SE5	Polymeric Enclosures	285
SE6	Spacings	285
SE7	Class 2 Disconnect Switch	286
SE8	Class 2 Separable Lead Assembly	286

PERFORMANCE

SE9	General	286
SE10	Class 2 Output Power Supply	286
SE11	Assembly Test	287

MARKINGS AND INSTRUCTIONS

SE12	Installation Instructions	288
SE13	User Instructions (General)	288
SE14	User Instructions (Separable Face Assembly as a Replacement Part)	289
SE15	Markings (General)	289
SE16	Markings (Separable Face Assembly as a Replacement Part)	290

SUPPLEMENT SF – RECESSED OUTLET KIT ASSEMBLY

INTRODUCTION

SF1	Scope	291
SF2	Glossary	291

CONSTRUCTION

SF3	General	291
SF4	Outlet Box	293
SF5	Outlet Box Cover or Cover Plate	293
SF6	Recessed Outlet	293
SF7	Recessed Inlet	293
SF8	Non-Metallic Sheathed Cable	293
SF9	Armored Cable	294

SF10	Armored Cable Connectors.....	294
SF11	Splices and Connections.....	294
SF12	Detachable Power Supply Cords.....	294
SF13	Accessibility of Live Parts	295

PERFORMANCE

SF14	Assembly Test	295
------	---------------------	-----

MARKINGS AND INSTRUCTIONS

SF15	Markings	295
SF16	Installation Instructions	296
SF17	User Instructions.....	297

APPENDIX A Standards for Components

APPENDIX B Wiring Device Configurations

ULNORM.COM : Click to view the full PDF of UL 498 2024

INTRODUCTION

1 Scope

1.1 These requirements cover attachment plugs, receptacles, cord connectors, inlets, current taps provided with wiring terminals for flexible cord, and flatiron and appliance plugs – all intended for connection to a branch circuit for use in accordance with the National Electrical Code, ANSI/NFPA 70.

1.2 These requirements do not cover devices rated at more than 200 A or for more than 600 V. See [6.1](#).

1.3 This Standard does not directly apply to, but supplements the following standards:

- a) Devices produced integrally with flexible cord or cable, covered by the Standard for Cord Sets and Power-Supply Cords, UL 817;
- b) Current taps and adapters not provided with wiring terminals for flexible cord covered by the Standard for Current Taps and Adapters, UL 498A;
- c) Devices employing male or female screwshells, covered by the Standard for Lampholders, UL 496;
- d) Devices solely intended for direct connection to the branch circuit in accordance with the National Electrical Code, ANSI/NFPA 70, that are provided with contacts of the pin and sleeve type, covered by the Standard for Plugs, Receptacles and Cable Connectors of the Pin-and-Sleeve Type, UL 1682;
- e) Single and multipole connectors intended for factory assembly to copper or copper alloy conductors or printed wiring boards for use in data, signal, control and power applications within and between electrical equipment, covered by the Standard for Component Connectors for Use in Data, Signal, Control and Power Applications, UL 1977;
- f) Devices intended for installation and use in hazardous (classified) locations in accordance with the National Electrical Code, ANSI/NFPA 70, covered by the Standard for Explosion-Proof and Dust-Ignition-Proof Electrical Equipment for Use in Hazardous (Classified) Locations, UL 1203;
- g) Devices intended for use with telecommunications networks, covered by the Standard for Information Technology Equipment – Safety – Part 1: General Requirements, UL 60950-1, or the Standard for Communications Circuit Accessories, UL 1863;
- h) Devices incorporating ground-fault circuit interruption circuitry, covered by the Standard for Ground-Fault Circuit Interrupters, UL 943;
- i) Single- or two-outlet direct plug-in devices incorporating transient voltage surge suppression circuitry, covered by the Standard for Surge Protective Devices, UL 1449;
- j) Single- or two-outlet direct plug-in devices incorporating electromagnetic interference filter circuitry, covered by the Standard for Electromagnetic Interference Filters, UL 1283;
- k) Cord-connected, relocatable power taps intended only for indoor use as a temporary extension of a grounding alternating-current branch circuit for general use, covered by the Standard for Relocatable Power Taps, UL 1363; or
- l) Single pole locking-type separable connectors, covered by the Standard for Single Pole Locking-Type Separable Connectors, UL 1691.

1.4 This Standard contains the following supplements:

- a) Supplement [SA](#) – Enclosure Types for Environmental Protection
- b) Supplement [SB](#) – Marine Shore Power Inlets
- c) Supplement [SC](#) – Hospital Grade Devices
- d) Supplement [SD](#) – Weather-Resistant Receptacles
- e) Supplement [SE](#) – Receptacles with Integral Power Supply with Class 2 Output Connectors
- f) Supplement [SF](#) – Recessed Outlet Kit Assembly

2 Glossary

2.1 For the purposes of this Standard, the following definitions apply.

2.2 **APPLIANCE COUPLER** – A single-outlet, female contact device for attachment to a flexible cord as part of a detachable power-supply cord to be connected to an inlet (motor attachment plug).

2.3 **APPLIANCE PLUG** – An appliance coupler type of device having a cord guard and a slot configuration specified for use with heating or cooking appliances.

2.3.1 **ATTACHMENT FITTING** – A male (load connected only) component device intended solely for factory assembly to utilization equipment for the purpose of connection to a luminaire and/or ceiling-suspended fan support receptacle.

2.4 **ATTACHMENT PLUG** – A male contact device for the temporary connection of a flexible cord or cable to a receptacle, cord connector, flanged equipment power outlet, or other outlet device.

2.5 **BULK SHIPMENT** – Any packaging container having more than one receptacle not provided with a unit container.

2.5.1 **CONFIGURABLE PLUG** – A male contact device employing repositionable blades, intended for the temporary connection of a flexible cord or cable to a receptacle, cord connector, or power outlet, of the corresponding mating device configuration.

2.6 **CONFIGURATION LOCKING** – A device having a configuration that requires a motion other than a straight push or pull to connect or separate it when used with its mating part.

2.7 **CORD CONNECTOR** – A female contact device to be wired on flexible cord for use as an extension from an outlet to make a detachable electrical connection to an attachment plug or, as an appliance coupler, to an equipment inlet.

2.8 **CURRENT TAP** – A device provided with one set of male blades, one or two female outlets, and wiring terminals for flexible cord intended either for factory or field wiring.

2.9 **ELECTRICAL (FUNCTIONAL) INSULATION** – The insulation necessary for the proper functioning of the product and for basic protection against electrical shock. This includes all parts relied upon to support live parts in place, all internal barriers necessary to maintain spacings, and the outlet face portion of all female devices.

2.10 **ENCLOSURE** – That part of the device that renders inaccessible all or any parts of the device that may otherwise present a risk of electric shock, retards propagation of flame initiated by electrical disturbances occurring within, or both.

2.11 **FIXTURE, EQUIPMENT, OR APPLIANCE OUTLET** – A receptacle outlet device for mounting on utilization equipment.

2.12 **FLATIRON PLUG** – An appliance coupler type of a device having a cord guard and a slot configuration specified for use with heating or cooking appliances.

2.13 **GROUNDING-CONDUCTOR PATH** – A path between the grounding pin, blade, or contact and the grounding terminal or, if the device has no grounding terminal, the point at which the path makes contact with a part of the metal raceway system, such as a box, box cover, or the raceway itself.

2.14 **GROUNDING DEVICE** – A device having a 5-15, 5-20, 5-30, 5-50, 6-15, 6-20, 6-30, 6-50, 7-15, 7-20, 7-30, 7-50, 14-15, 14-20, 14-30, 14-50, 14-60, 15-15, 15-20, 15-30, 15-50, 15-60, L5-15, L5-20, L5-30, L6-15, L6-20, L6-30, L7-15, L7-20, L7-30, L8-20, L8-30, L9-20, L9-30, L14-20, L14-30, L15-20, L15-30, L16-20, L16-30, L17-30, L21-20, L21-30, L22-20, L22-30, L23-20, L23-30, TT-R, or ML-2R configuration, the standard configuration illustrated in Figure C1.1 of the Standard for Wiring Device Configurations, UL 1681, or a nonstandard configuration that employs one blade, pin, or contact exclusively for grounding.

2.15 **HOUSING ADAPTER, ANGLE** – A part that is intended to replace a portion of an attachment plug or cord connector housing so that the flexible cord exits the strain relief in the same plane as the face of the device.

2.16 **HOUSING ADAPTER, SHROUD** – A part that is intended to be assembled onto an attachment plug or cord connector to extend the housing beyond the plane of the face of the device.

2.17 **INLET** – (Motor Attachment Plug) A male contact device to be mounted on utilization equipment to provide an integral blade configuration for the connection of an appliance coupler or cord connector.

2.18 **POLARIZED DEVICE** – A device constructed for connection to a mating device only in the position that connects related poles of an electrical circuit.

2.18.1 **RECEPTACLE, CEILING-SUSPENDED FAN SUPPORT** – A type of receptacle intended to be secured to a ceiling outlet box. Provides electrical connection and mechanical support of a ceiling-suspended fan by a factory installed attachment fitting secured to a ceiling-suspended fan.

2.19 **RECEPTACLE, CLOCK** – A flush receptacle having a recessed cord-storage space in an integral flush-device cover plate, commonly used with wall clocks.

2.20 **RECEPTACLE, DISPLAY** – A flush receptacle provided with a flush device plate or outlet box cover and closure plug or plugs that is intended for use in show window floors and similar locations where the device is not likely to be subjected to scrub water.

2.21 **RECEPTACLE, DUPLEX** – A receptacle having two contact devices on a single mounting yoke for flush mounting in a plane surface.

2.22 **RECEPTACLE, FLUSH** – A receptacle which is intended for mounting in or on an outlet box, an outlet-box cover, or a flush-device cover plate for fixed installation on a branch circuit.

2.23 **RECEPTACLE, INTERCHANGEABLE or MODULAR** – A flush receptacle which is assembled as a single, duplex or triplex outlet in the field from a system of individual outlet modules, mounting yokes, or flush device cover plates.

2.24 **RECEPTACLE, ISOLATED GROUND** – A receptacle having the grounding terminal electrically isolated from the system ground when installed in a metallic outlet box or raceway system.

2.24.1 RECEPTACLE, LIGHTED – A receptacle employing an integral lens (jewel) and electrical or electronic components that produce light. Two basic types:

- a) Power Indicator type – Illuminates to indicate power is on.
- b) Illuminated/Nightlight – Illuminates when power is on and may not when controlled by a photoelectric sensor.

2.24.2 RECEPTACLE, LUMINAIRE SUPPORT – A type of receptacle intended to be secured to a ceiling outlet box. Provides electrical connection and mechanical support of a luminaire by a factory installed attachment fitting secured to the luminaire.

2.25 RECEPTACLE, PENDANT – Pendant receptacles include an enclosure with cover plate and strain relief means, intended to be assembled at the end of flexible cord, for use in branch circuit applications.

2.26 RECEPTACLE, POP-OUT – A retractable flush mount receptacle intended for mounting in or on an outlet box, an outlet-box cover, or a flush device plate for fixed installation on a branch circuit and is only intended to be installed in a wall and other vertical surfaces.

2.27 RECEPTACLE, POP-UP ASSEMBLY – An assembly consisting of a retractable flush mount receptacle, outlet box and flush device cover plate intended for fixed installation on a branch circuit. A pop-up receptacle assembly is suitable for installation in a kitchen or bathroom countertop. They are provided with one or more receptacle outlets. The outlets are retractable for storage below the counter surface.

2.28 RECEPTACLE, SELF-CONTAINED – A receptacle which includes an enclosure and mounting means intended for flush mounting without the use of a separate flush-device or other outlet box and for connection to one or more nonmetallic sheathed cables containing copper conductors in accordance with National Electrical Code, ANSI/NFPA 70. A self-contained receptacle is primarily used in mobile homes, recreational vehicles, manufactured buildings, and on-site frame construction.

2.29 RECEPTACLE, SELF-GROUNDING – A receptacle which includes a spring clip or other part to provide for electrical continuity between the grounded device yoke and the mounting screw.

2.30 RECEPTACLE, SPLIT – A duplex receptacle having line terminals which are capable of being electrically separated.

2.31 RECEPTACLE, SURFACE-MOUNT – A receptacle which includes an enclosure and mounting means intended for surface mounting without the use of a separate outlet box in accordance with the National Electrical Code, ANSI/NFPA 70.

2.32 RECEPTACLE, TAMPER-RESISTANT – A receptacle which by its construction is intended to limit improper access to its energized contacts in accordance with the National Electrical Code, ANSI/NFPA 70.

2.33 RECEPTACLE, WEATHER-RESISTANT – A flush-type receptacle which by its construction is intended to provide resistance to the effects of outdoor exposure when installed in accordance with Article 406 of the National Electrical Code, ANSI/NFPA 70.

2.34 SELF-HINGE – A thin molded portion of an enclosure intended to bend during the assembly of a wiring device to a flexible cord.

2.35 TABLE TAP – A cord connector having more than one outlet and intended to rest on a horizontal surface while in use.

2.36 **TERMINAL, INSULATION-DISPLACEMENT** – A terminal having a contacting member that forces the conductor insulation aside and presses against the side of the conductor to make contact.

2.37 **TERMINAL, PIN-TYPE (INSULATION-PIERCING)** – A terminal having a contact pin that punctures the conductor insulation to contact the current-carrying conductor.

2.38 **TERMINAL, PRESSURE-WIRE** – A terminal which establishes a connection between one or more conductors and a terminal plate by means of mechanical pressure without the use of solder. A pressure-wire terminal may be either of the following types:

a) **Clamp-Type** – A pressure-wire terminal in which the conductor is held under a pressure plate or saddle clamp by one or more screws. This type of terminal may be provided in combination with a wire-binding screw terminal.

b) **Setscrew-Type** – A pressure-wire terminal in which the pressure is applied by the end of the screw bearing on the conductor, either directly or through a wire-protecting pad.

c) **Combination Wire Binding/Pressure-Type** – A wire binding screw with an integrally machined pressure ring. Pressure ring terminals accept both single and multiple conductors that are captured under the machine formed pressure ring. These terminals may be wired with a single conductor using the conventional 3/4 loop around the wire-binding screw.

2.39 **TERMINAL, PUSH-IN** – A terminal where the stripped end of a conductor is pushed into the terminal and the clamping pressure is maintained by a spring mechanism, without the use of screws.

2.39.1 **TERMINAL, SPRING ACTION CLAMP** – A terminal where the stripped end of a conductor is inserted into the terminal and a manually operated integral lever applies clamping pressure to a spring mechanism, without the use of screws.

2.40 **TERMINAL, WIRE-BINDING SCREW** – A terminal in which the conductor is bent around the screw and is clamped directly under the head of the screw when it is tightened.

2.41 **TERMINAL ASSEMBLY, SEPARABLE** – A two-piece terminal assembly provided with an integral mechanical latching mechanism(s). It consists of permanently attached pins or tabs located on the body of the receptacle and is capable of receiving a special purpose connector with leads for connection to the branch circuit.

2.42 **THROUGH-WIRING** – A wiring method which permits a group of receptacles to be wired in parallel to a common branch circuit.

2.43 **UNIT CONTAINER** – The smallest carton, package, or container, in which a receptacle is packaged. A unit container may contain more than one receptacle if they are not intended to be removed from the container for individual sale.

3 Components

3.1 Except as indicated in [3.2](#), a component of a product covered by this Standard shall comply with the requirements for that component. See Appendix [A](#) for a list of standards covering components generally used in the products covered by this Standard.

3.2 A component is not required to comply with a specific requirement that:

a) Involves a feature or characteristic not required in the application of the component in the product covered by this standard, or

b) Is superseded by a requirement in this standard.

3.3 A component shall be used in accordance with its rating established for the intended conditions of use.

3.4 Specific components are incomplete in construction features or restricted in performance capabilities. Such components are intended for use only under limited conditions, such as certain temperatures not exceeding specified limits, and shall be used only under those specific conditions.

4 Units of Measurement

4.1 When a value for measurement is followed by a value in other units in parentheses, the first stated value is the requirement.

5 References

5.1 Any undated reference to a code or standard appearing in the requirements of this standard shall be interpreted as referring to the latest edition of that code or standard.

CONSTRUCTION

ALL DEVICES

6 General

6.1 The ratings mentioned throughout this Standard including those mentioned in [Table 192.1](#) represent maximum ampacity and maximum operating potential in volts for receptacles and other outlet devices such as cord connectors or current taps.

6.2 A device is considered to be for use on either alternating or direct current unless the rating includes the letters "ac" to restrict the use to alternating current.

7 Configurations

7.1 The NEMA configurations of various attachment plug and receptacle combinations referenced in this Standard are in accordance with Wiring Devices – Dimensional Specifications, ANSI/NEMA WD6, and are included in Appendix [E](#) for ease of reference. The figures referenced as Section C1 contain non-NEMA configurations and are found in the Standard for Wiring Device Configurations, UL 1681.

7.2 The ESTA configurations of various attachment plugs and receptacle combinations referenced in this Standard are in accordance with Entertainment Technology Dimensional Requirements for Stage Pin Connectors, ANSI/ESTA E1.24.

8 Insulating Materials

8.1 General

8.1.1 All parts that act as the electrical insulation or enclosure of a device shall be made of an insulating material intended for the particular application and shall comply with the requirements in [8.2.1](#) – [8.4.1](#). Hard rubber shall not be employed.

Exception No. 1: The internal insulating systems of components where component requirements exist are not required to comply with the requirements in [8.2.1](#) – [8.4.1](#).

Exception No. 2: A small part meeting all of the following criteria is not required to comply with the requirements in [8.2.1](#) – [8.4.1](#):

- a) Its volume does not exceed 0.122 cubic inch (2 cm³),*
- b) Its maximum dimension does not exceed 1.18 inches (3 cm), and*
- c) Its location is such that it cannot propagate flame from one area to another or act as a bridge between a possible source of ignition and other ignitable parts.*

Exception No. 3: Fiber or similar material that is equal to or less than 0.010 inch (0.25 mm) thick is not required to comply with the requirements in [8.2.1](#) – [8.4.1](#).

8.1.2 A polymeric material used for electrical insulation or enclosure of live parts shall be fabricated in accordance with the Standard for Polymeric Materials – Fabricated Parts, UL 746D.

Exception: A polymeric material that is fabricated in the same location where final assembly takes place and where no blending or compounding operations are involved is not required to comply with this requirement.

8.2 Flammability

8.2.1 A polymeric material used for electrical insulation or enclosure of live parts shall have a flame class rating of HB, V-2, V-1, V-0, VTM-2, VTM-1, or VTM-0 in accordance with the requirements of the Standard for Tests for Flammability of Plastic Materials for Parts in Devices and Appliances, UL 94. The flame class rating of the material shall be judged at the minimum thickness employed at the walls and barriers in the device which are critical to the functioning of the insulation or enclosure of the device.

Exception No. 1: Insulating materials employed in a self-contained receptacle shall instead comply with [40.1](#).

Exception No. 2: A polymeric material that complies with either the 12 mm or 20 mm (3/4-inch) flame flammability test described in the Standard for Polymeric Materials – Use in Electrical Equipment Evaluations, UL 746C, need not have a flammability class rating.

8.3 Electrical properties

8.3.1 A polymeric material used for electrical insulation or enclosure of live parts shall have a Comparative Tracking Index (CTI) rating of 175 V or greater or a performance level class of at least 3.

Exception No. 1: A polymeric material used for electrical insulation or enclosure of live parts is not required to comply with this requirement if it complies with the Comparative Tracking Index Test, Section [60](#).

Exception No. 2: A polymeric material used in an enclosure that is separated through air by more than 1/32 inches (0.8 mm) from uninsulated live parts and more than 1/2 inch (12.7 mm) from arcing parts is not required to comply with this requirement.

8.3.2 A polymeric material used for electrical insulation or enclosure of live parts shall have Hot Wire Ignition (HWI) and High-Current Arc Resistance to Ignition (HAI) ratings or performance level classes of at least those shown in [Table 8.1](#) for the flame class rating determined in accordance with [8.2.1](#). For materials with other than VTM flammability classifications, the HWI and HAI ratings of the material shall be evaluated using the specimen thickness employed in the end product or nominal 1/8 inch (3.2 mm) thickness, whichever is greater.

Exception No. 1: A polymeric material used for electrical insulation or enclosure of live parts is not required to comply with the HWI requirements if it complies with the Glow Wire Test, Section 61.

Exception No. 2: A polymeric material used for electrical insulation or enclosure of live parts is not required to comply with the HAI requirements if it complies with the High-Current Arc Resistance to Ignition Test, Section 62.

Exception No. 3: A polymeric material used in an enclosure of an attachment plug or cord connector which does not enclose live parts, or which encloses insulated live parts where the insulation thickness is greater than 0.028 inches (0.71 mm), is not required to comply with the HWI requirements.

Exception No. 4: A polymeric material used in an enclosure that is separated through air by more than 1/32 inches (0.8 mm) from uninsulated live parts and more than 1/2 inch (12.7 mm) from arcing parts is not required to comply with the HWI and HAI requirements.

Exception No. 5: Insulating materials employed in a self-contained receptacle shall instead comply with 40.1.

Table 8.1
Hot wire ignition (HWI) and high-current arc resistance to ignition (HAI) ratings of insulating materials

Flammability classification ^a	HWI ^{b,d}		HAI ^{c,d}	
	Mean ignition time (sec)	PLC	Mean no. of arcs	PLC
V-0, VTM-0	7 and up to 15	4	15 and up to 30	3
V-1, VTM-1 ^e	15 and up to 30	3	15 and up to 30	3
V-2, VTM-2	15 and up to 30	3	15 and up to 30	3
HB	30 or more	2	60 or more	1

^a Flammability classification – Described in the Standard for Tests for Flammability of Plastic Materials for Parts in Devices and Appliances, UL 94.

^b Hot Wire Resistance to Ignition – Described in the Standard for Polymeric Materials – Short Term Property Evaluations, UL 746A.

^c High-Current Arc Resistance to Ignition – Described in UL 746A.

^d Mean ignition time and mean no. of arcs to be used to evaluate Filament Wound Tubing, Industrial Laminates, Vulcanized Fiber, and similar polymeric materials only. All other materials are to be judged using the performance level class values.

^e polymeric material subjected to the flammability test with either the 12 mm or 20 mm (3/4-inch) flame in accordance with Exception No. 2 to 8.2.1 shall comply with the PLC for a V-1 rating.

8.4 Thermal properties

8.4.1 A polymeric material used for electrical insulation or enclosure of live parts shall have the relative thermal index ratings shown in Table 8.2 for the specific application of the insulating material. For materials with other than VTM flammability classifications, the material shall be evaluated using the specimen thickness employed in the end product or nominal 1/8 inch (3.2 mm) thickness, whichever is greater.

Exception: The following generic materials having readings of 65 or less on the Shore Durometer D scale (when measured for 5 seconds at an ambient temperature of 23.0 ± 2.0°C (73.4 ± 3.6°F)) are acceptable for use at 60°C (140°F) based on their successful completion of the appropriate accelerated aging test described in Accelerated Aging Tests, Section 66:

- a) Ethylene/Propylene/Diene (EPDM)

- b) *Natural Rubber (NR)*
- c) *Neoprene (Chloroprene Butadiene) Rubber (CBR)*
- d) *Nitrile Rubber (NBR)*
- e) *Polyvinyl Chloride (PVC) and its copolymers*
- f) *Silicone Rubber (SIR)*
- g) *Styrene (Butadiene) Rubber (SBR)*
- h) *Thermo Elastomeric [TEE; includes Thermoplastic Elastomers (TPE) and Ethylene Propylene Thermoplastic Rubber (EPTR)]*

**Table 8.2
Minimum relative thermal indices of insulating materials used in insulation and enclosure applications**

Application	Minimum relative thermal index ^a , Degrees C		
	Electrical	Mechanical with impact ^b	Mechanical without impact
Permanently-wired devices (including appliance, fixture and equipment outlets, inlets, and receptacles)	80°	60°	80°
Cord-connected devices (including attachment plugs, cord connectors, and current taps)	60°	60°	60°

^a Relative Thermal Index – Described in the Standard for Polymeric Materials – Long Term Property Evaluations, UL 746B.
^b For industrial laminates, vulcanized fiber, and similar polymeric materials, the material's minimum RTI for Mechanical shall be evaluated using the values specified for Mechanical Without Impact.
^c For devices containing fuses, the minimum thermal indices shall be the values shown above or the temperature measured on the insulating material during the Fuseholder Temperature Test, whichever is greater. See Sections [78](#), [88](#), [99](#), and [121](#).

8.5 Vulcanized fiber

8.5.1 Vulcanized fiber is not prohibited from being used for insulating washers, separators, and barriers, but shall not be used as the sole support of live parts.

8.5.2 Vulcanized fiber shall comply with the requirements in [8.2.1](#) – [8.4.1](#) and shall be moisture-resistant in accordance with [64.1](#) and [64.2](#).

8.6 Sealing compounds

8.6.1 A sealing compound shall be insulating, waterproof, and shall not soften at a temperature of 65°C (149°F). The softening point is to be determined using the Standard Test Methods for Softening Point of Resins Derived from Naval Stores by Ring-and-Ball Apparatus, ASTM E28.

8.6.2 Sulphur shall not be employed as a sealing compound.

8.7 Fuse enclosures

8.7.1 A fuse enclosure shall be of a moisture-resistant material in accordance with [64.1](#) and [64.2](#). Fiber and similar absorptive materials shall not be used for the enclosure of a fuse.

8.7.2 A polymeric material classified as Type V-0, V-1, or V-2 is considered as having flammability properties acceptable for use as the enclosure of a fuse.

9 Enclosure

9.1 General

9.1.1 A device shall have live parts protected against exposure to contact by persons when fully assembled using all essential parts (described in [9.1.5](#)) and installed in the intended manner.

Exception No. 1: Male blades which are energized only when mated with the corresponding outlet are not required to comply with this requirement.

Exception No. 2: Exposed wiring terminals or other live parts enclosed within equipment or within an outlet box when the device is installed in the intended manner are not required to comply with this requirement.

9.1.2 Accessible dead-metal parts of a grounding device shall be conductively connected to the grounding-conductor path through the device.

Exception: Accessible dead-metal parts electrically insulated from current-carrying parts are not required to comply with this requirement.

9.1.3 Accessible dead-metal parts of a nongrounding device shall be electrically insulated from live parts and wiring other than the complete flexible cord so that they are unable to be energized by stray strands, failure of wiring terminals (such as loosening of screws), or damaged or broken wiring. When the stray strand length affects whether a device complies with this requirement, the device shall be marked in accordance with Reference No. 3 to [Table 193.1](#). See [9.1.7](#).

9.1.4 In order to judge the accessibility of a live or dead-metal part, the device is to be wired and assembled in accordance with the manufacturer's instructions, except that any nonessential parts (described in [9.1.6](#)) that are able to be opened or removed by the user without using a tool are to be opened or removed. The probe shown in [Figure 9.1](#) is to be applied with a force of not more than 3 lbf (13.3 N) to any depth that recessing will permit. The probe is to be rotated, changed in configuration, or angled before, during, and after application to any position that is necessary to examine the device. A live or dead-metal part is determined to be accessible when:

- a) The part is contacted by the probe, or
- b) The part is located in a hole larger than 7.1 mm (9/32 inch) in diameter and recessed less than 4.8 mm (3/16 inch).

Figure 9.1
Articulate probe with web stop

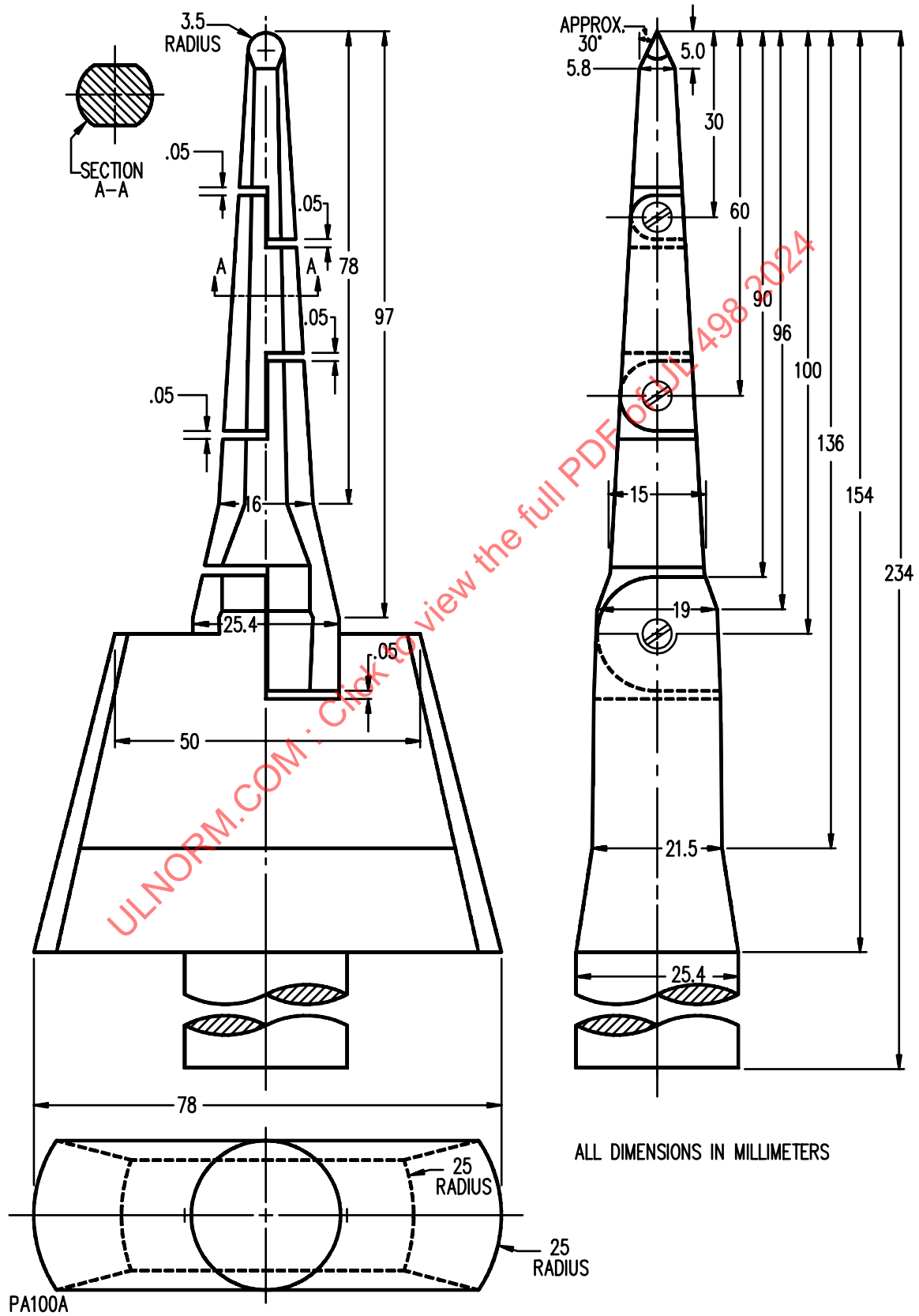

9.1.5 A separable part is considered essential for the operation of the device if it employs a latch or detent or requires use of a tool to remove, and if it performs any of the following functions:

- a) Encloses or completes the enclosure of current-carrying parts other than those on the male face of an attachment plug or current tap;
- b) Encloses or completes the enclosure of the flexible cord from which the jacket has been removed for wiring;
- c) Mechanically secures flexible cord to pin-type terminals; or
- d) Provides for the placement and removal of a fuse.

9.1.6 A separable part (such as an insulating face cover, disc or strain relief clamp) is not considered essential for the operation of the device if it can be removed without the use of a tool or without defeating a latch or detent and if it performs any of the following functions:

- a) Provides strain relief;
- b) Encloses wiring terminals that would otherwise be exposed on the male face of an attachment plug or current tap; or
- c) Provides access to a fuse through the male face of an attachment plug or current tap.

9.1.7 With respect to [9.1.5\(b\)](#), the enclosure of a flexible cord is not considered to be complete where two insulated conductors of a parallel-type cord are split apart or where the jacket is removed from the insulated conductors of a jacketed-type cord.

9.2 Male faces and wire terminations

9.2.1 The wire terminations of a 15 or 20 A attachment plug or current tap shall be completely enclosed when the device is wired on flexible cord and assembled as intended, using only those parts essential for the operation of the device (dead-front construction). See [9.1.5](#) and [9.1.6](#).

9.2.2 An exposed live part on the face of an attachment plug or current tap rated other than 15 or 20 A shall be provided with an insulating disc or face cover that is at least 0.028 inch (0.71 mm) thick and completely covers all exposed live parts. Any unfilled openings on a face cover or disc provided with multiple clearance openings to enable its use with a number of blade arrangements are to be located opposite the anticipated insulating face of the corresponding outlet device.

9.2.3 An insulating disc or face cover intended to be opened or removed to provide access to the wiring terminals shall be mechanically secured after wiring by one or more screws, latches, or detents that cannot be unintentionally opened or removed. A cover that is held in place by only friction without any positive detent action is not considered mechanically secured and is to be subjected to the Secureness-Of-Cover Test described in Section [72](#).

9.2.4 An insulating disc or face cover shall enclose the wiring terminal compartments with a fit at the periphery that will not permit the entrance of a 0.030 inch diameter (0.76 mm) probe.

Exception: A notch may be provided in the cover to facilitate removal but only in areas remote from wiring terminals so that unclamped live strands cannot reach the opening. The notch is to comply with all of the following:

- a) *It shall not be deeper than 1/8 inch (3.2 mm) from the periphery;*
- b) *It shall not be wider than 3/8 inch (9.5 mm) along the periphery of the cover; and*

c) It shall not be located within 3/8 inch (9.5 mm) of the binding screw head as measured from the closest point in the notch periphery.

9.2.5 A device with a separable face cover shall be capable of being properly wired with the maximum size of the heaviest-duty type of flexible cord intended without inhibiting the full seating of the cover. The flexible cord used to determine compliance shall either:

- a) Have an ampacity at least equal to the rating of the device configuration;
- b) Be of the type and size marked on the device; or
- c) Be of the maximum size that can be accommodated by the cord-entrance opening into the device.

9.2.6 An attachment plug or current tap with a separable face cover or disc shall be shipped with the cover attached to the device but not necessarily mechanically secured.

10 Current-Carrying Parts

10.1 General

10.1.1 Iron or steel, plated or unplated, shall not be used for parts that are depended upon to carry current.

Exception No. 1: Stainless steel may be employed for a part not subject to arcing.

Exception No. 2: A steel that is corrosion-resistant (stainless) or is protected against corrosion by cadmium plating, zinc plating, or an equivalent protective coating, may be used for wire-binding nuts and screws if these parts are not depended upon to carry current.

Exception No. 3: Iron or steel current-carrying parts employed on a flatiron or appliance plug are not prohibited when protected against corrosion by a metallic plating or other metal coating. See [52.1](#).

10.1.2 A current-carrying part shall be restricted from turning relative to the surface on which it is mounted if such turning would adversely affect the performance of the device.

10.1.3 Uninsulated live parts shall be secured in place so that a reduction in the spacings below those required in [14.1](#) is not likely.

10.2 Contacts

10.2.1 Female contacts and associated live parts in the contact opening of an outlet device that can be touched by the probe illustrated in [Figure 10.1](#) shall be recessed from the plane of the opening a distance not less than 1/4 of the maximum straight-line dimension of the opening, or 3/64 inch (1.2 mm), whichever is larger. That plane nearest the face of the device having the minimum opening for the pin or blade clearance is to be used to determine the minimum recess. Bevels, tapers, or other expansions of the opening to the face of the device do not affect the measurement. The probe in [Figure 10.1](#) is to be inserted point first as far as possible in the opening without distorting the perimeter of the opening. The maximum straight-line dimension is the maximum-length straight-line that will fit within the opening at the plane of measurement.

Exception No. 1: A cord-connector having a 1-15R configuration shall comply with [23.1.1](#).

Exception No. 2: Devices having openings that close upon removal of the attachment plug are not required to comply with this requirement.

Exception No. 3: Specific-purpose devices intended only for disconnecting use (see [192.6](#)), are not required to comply with this requirement.

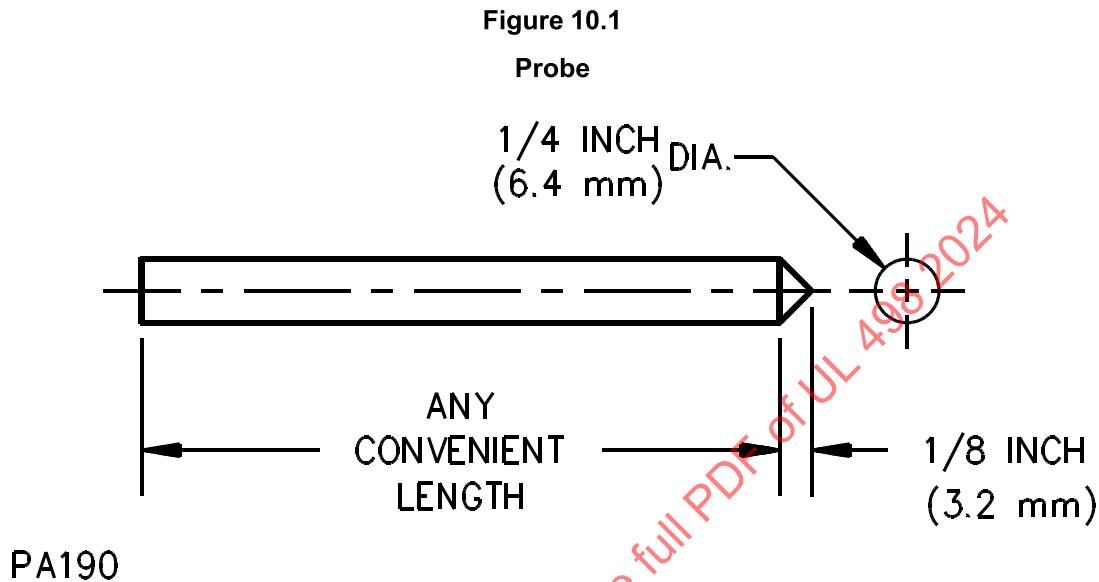

11 Grounding and Dead Metal Parts

11.1 The following grounding parts shall be of copper or of a copper-base alloy:

- a) The grounding pin, blade, or contact,
- b) The grounding-conductor path through an attachment plug, current tap or cord connector, except for a metal housing or armor, and
- c) The grounding-conductor path through a receptacle up to the strap, yoke, or other mounting means.

Exception: A rivet, bolt, or clamp that is used to secure parts in the grounding-conductor path, but which is not an essential conductor in the grounding-conductor path, may be of steel or its equivalent.

11.2 A copper-base-alloy rivet that is used to secure parts in the grounding-conductor path, or that forms a part of the grounding-conductor path, shall not contain less than 80 percent copper.

11.3 The grounding-conductor path connections in a grounding device shall be secured by riveting, bolting, welding, or equivalent means.

Exception: Another form of connection employed in a cord connector is not prohibited when the connection complies with the requirement in Potential Drop in Grounding Connections Test, Section [101](#).

11.4 The grounding pin, blade, or contact, of a grounding device shall be permanently attached to the body of the device.

Exception: A device in which the grounding member is mounted in soft rubber or similarly flexible material is not precluded by this requirement. The requirement contemplates that the element is to be secured in a manner so that it is not readily removable or movable.

11.5 Grounding and other dead metal parts shall be secured in place so that a reduction in spacings below those required in [14.1](#) is not likely.

11.6 The grounding terminal of a grounding device shall be connected to the contact that is intended for use for equipment grounding. For devices having one of the standard grounding configurations, the grounding contact is identified by the letter "G" in the corresponding figure in Wiring Devices – Dimensional Specifications, ANSI/NEMA WD6, and in the Standard for Wiring Device Configurations, UL 1681. The grounding terminal shall be permanently identified in accordance with [194.1.1](#) in a manner that is readily recognizable during installation. See also [19.1](#), [24.1](#), [29.1.2](#), and Section [194](#), Identification and Marking of Terminals.

11.7 Dead-metal parts of a grounding device shall be conductively connected to the grounding-conductor path through the device. See [9.1.2](#).

Exception: Dead-metal parts isolated from current-carrying parts and wiring other than complete flexible cords (see [9.1.7](#)) are not required to comply with this requirement.

11.8 A conductive connection between a blade, pin, or contact, and an exposed dead-metal part capable of being grounded in service, such as the mounting strap, yoke, or body armor, shall be provided only in a grounding device. A nongrounding device with exposed dead-metal parts shall not be provided with a wiring terminal identified for an equipment grounding conductor. See also [19.4](#) and [24.2](#).

Exception: A nonstandard-configuration device that does not employ a dedicated grounding blade, pin, or contact, but which uses body armor or similar exposed metal parts as an equipment grounding conductor is not prohibited from being provided with an equipment grounding terminal only when the conductive connection between the grounding terminal and the exposed metal parts is obvious to the installer.

11.9 Dead metal parts of a device for use in nongrounding applications shall be insulated from live parts and wiring other than the complete flexible cord so that stray strands, failure of wiring terminals, or failure of wiring shall not energize accessible dead metal parts. See [9.1.3](#).

11.10 Iron or steel other than machine screws, washers, nuts, and stainless steel parts shall be protected against corrosion.

Exception: Parts determined to comply with [31.2.4](#) and [52.1](#), are not required to comply with this requirement.

12 Terminals

12.1 General

12.1.1 When a device is intended for the connection of conductors, a means shall be provided for connection such as a wire-binding screw or pressure-wire type wiring terminal, or a lead that is factory-assembled by means of soldering, welding, riveting or crimping. A wire-binding screw terminal shall not be used for the connection of circuit wires to a device rated more than 30 A and intended for connection to conductors greater than 10 AWG (5.3 mm²).

Exception: Other forms of construction, such as push-in or insulation-displacement terminals, may be accepted if the mechanical features and current-carrying capability are equivalent to those of the connections mentioned above. See also [20.1.1](#), [25.1](#), [30.2.1](#), and [30.3.1](#).

12.1.2 A terminal provided for the field connection of a grounding conductor shall employ a mechanical clamping means that does not depend upon solder for the connection of the wire.

12.2 Wire-binding screw terminals

12.2.1 A wiring terminal that involves a wire-binding screw shall have upturned lugs, or the equivalent, to hold a wire under the head of the screw.

12.2.2 A terminal plate that has a tapped hole for a wire-binding screw shall be of 0.030 inch (0.76 mm) or thicker metal and shall not have fewer than two full threads in the metal. A binding screw that has 32 or more threads per inch (per 25.4 mm) with a terminal plate formed from stock 0.030 inch (0.76 mm) thick, may have the metal extruded at the tapped hole to provide two full threads for the binding screw.

12.2.3 A wire-binding screw shall thread into metal.

12.2.4 The minimum size and maximum number of threads per inch (per 25.4 mm) for a wire-binding screw shall be as indicated in [Table 12.1](#).

Table 12.1
Sizes of terminal screws

Rating of device in amperes	Minimum size of screw	Maximum number of threads per inch (per 25.4 mm)
15 or less	6 ^a	36 ^c
20	8 ^b	32 ^c
30	8	32

^a No. 5-40 screws may be used on devices intended only for other than outlet-box use.

^b No. 6-36 screws with a 0.296 inch diameter (7.52 mm) or larger head may be used for terminals on attachment plugs and cord connectors. On the device with a 5-20 configuration, the terminal screw that is used for connecting the grounding conductor to the outlet box shall not be smaller than No. 6-36.

^c No. 8 or larger screws having more than the number of threads per inch (per 25.4 mm) indicated may be used for terminals when the assembly complies with the Tightening Torque Test, Section [69](#).

12.2.5 A receptacle or inlet rated 30 A or less and employing wire-binding screw terminals for connection to copper branch circuit conductors only, shall comply with the general performance requirements for receptacles, Sections [110](#) – [125](#), or the general performance requirements for inlets, Sections [85](#) – [88](#), as applicable.

12.2.6 In addition to the requirements in Sections [110](#) – [125](#), a receptacle rated 15 or 20 A and employing wire-binding screw terminals for connection to copper and/or aluminum branch circuit conductors shall comply with the CO/ALR Type requirements contained in [35.1](#).

12.2.7 The tightening torque for the wire-binding screw terminals shall be specified by the device manufacturer and shall be marked as described in Reference No. 4 of [Table 193.2](#) for inlets and Reference No. 18 of [Table 193.4](#) for receptacles.

12.3 Soldering lugs

12.3.1 A terminal plate for a soldering lug shall be at least 0.050 in (1.27 mm) thick and shall not have fewer than two full threads in the metal for a terminal screw.

12.4 Pressure-wire terminals

12.4.1 A terminal plate for a pressure-wire terminal shall be at least 0.030 inch (0.76 mm) thick and shall not have fewer than two full threads in the metal for a terminal screw.

12.4.2 A pressure-wire terminal intended for the connection of branch circuit conductors to an inlet or receptacle shall be investigated in accordance with [Table 12.2](#).

Table 12.2
Pressure-wire terminals used in receptacles and inlets

Use	Current rating	Pressure-wire terminal type	Reference paragraphs
Copper wire only	<30A	Clamp	89.2 , 126.3
		Setscrew	12.4.3 , 89.1 , 126.2
	≥35A	Clamp	12.4.3 , 89.1 , 126.3
		Setscrew	12.4.3 , 89.1 , 126.3
Copper or aluminum wire	All	All	12.4.3 , 36.1 , 126.1

12.4.3 The tightening torque for the pressure-wire terminals designated in [Table 12.2](#) shall be specified by the device manufacturer and shall be marked as described in Reference No. 4 of [Table 193.2](#) for inlets and Reference No. 18 of [Table 193.4](#) for receptacles. The specified tightening torque shall not be less than 90 percent of the value employed in the static heating test in the Standard for Equipment Wiring Terminals for Use with Aluminum and/or Copper Conductors, UL 486E, for the maximum wire size corresponding to the ampere rating of the device.

Exception: A lesser torque value is not prohibited when the connector is investigated in accordance with the Standard for Wire Connectors, UL 486A-486B or UL 486E using the lesser assigned torque value.

12.5 Combination wire binding/pressure-wire terminals

12.5.1 A receptacle or inlet employing a combination wire binding/pressure-type terminal shall be limited to 10, 12 or 14 AWG conductors. The terminals shall comply with the applicable performance requirements as specified in the Standard for Equipment Wiring Terminals for Use with Aluminum and/or Copper Conductors, UL 486E.

12.5.2 A receptacle or inlet employing a combination wire binding/pressure-wire terminal for connection to copper branch circuit conductors only, shall comply with the general performance requirements for receptacles, as specified in Sections [110](#) – [125](#) and [90](#), Combination Wire Binding/Pressure Wire-Type Terminals, or the general performance requirements for inlets, Sections [85](#) – [88](#), and [90](#) as applicable.

12.5.3 In addition to the requirements in [12.5.2](#), a receptacle rated 15 or 20 A and employing a combination wire binding/pressure-type terminal for connection to aluminum branch circuit conductors shall also comply with the CO/ALR Type requirements contained in [35.1](#).

12.6 Spring action clamp terminals

12.6.1 In addition to the requirements contained in this standard, a device employing a spring action clamp terminal shall also comply with the applicable requirements, as specified in the Standard for Equipment Wiring Terminals for Use with Aluminum and/or Copper Conductors, UL 486E. All tests shall be investigated with minimum and maximum conductor AWG size and for each type of conductor (solid and stranded), for each device construction.

Exception: The spring-action clamp terminals of a Hospital Grade attachment plug or cord connector complying with Strain Relief Tests in Supplement SC – Hospital Grade Devices, shall not be subjected to the mechanical sequence (Secureness and Pullout) of the Standard for Equipment Wiring Terminals for Use with Aluminum and/or Copper Conductors, UL 486E.

12.6.2 A receptacle or inlet employing spring action clamp terminals are intended for either stranded or solid or both, and type of conductor as specified by the manufacturer.

12.6.3 A receptacle or inlet employing spring action clamp terminals are intended for the connection of a single conductor only.

12.6.4 An attachment plug or cord connector employing spring action clamp terminals are intended for the connection to flexible cord only.

12.7 Attachment fitting

12.7.1 An attachment fitting may only be factory assembled to utilization equipment for the purpose of connection to a luminaire and/or ceiling-suspended fan support receptacle of the same manufacturer.

12.7.2 An attachment fitting shall have securement redundancy when inserted into either a luminaire and/or ceiling-suspended fan. Compliance is checked by visual inspection.

12.7.3 An attachment fitting when fully inserted as intended into either a luminaire or ceiling-suspended fan receptacle shall bond all dead metal to the receptacle grounding terminal.

12.7.4 An attachment fitting shall be configured in such a manner as to prevent interchangeability with differently rated receptacles. It shall not be possible to mate an attachment fitting with either a luminaire or ceiling-suspended fan support receptacle having a lower rating as identified in [Table 12.3](#).

Table 12.3
Attachment fitting load rating

Attachment fitting load rating	Intended receptacle	Receptacle rating
50 lb. Luminaire Support	Luminaire Support Receptacle	Luminaire/Fixture 50 lb Minimum
35 lb. Fan Support	Ceiling-suspended Fan Support Receptacle ^a	Fan Support 35 lb. Minimum Luminaire/Fixture 50 lb. Minimum
50 lb. Fan Support	Ceiling-suspended Fan Support Receptacle ^a	Fan Support 50 lb. Minimum Luminaire/Fixture 50 lb. Minimum
70 lb. Fan Support	Ceiling-suspended Fan Support Receptacle ^a	Fan Support 70 lb. Minimum Luminaire/Fixture 70 lb. Minimum

^a Identified load rating shall be specified by the manufacturer and so marked. See [Table 193.1](#) and [Table 193.4](#) for marking details.

12.7.5 An attachment fitting and luminaire or ceiling-suspended fan support receptacle which utilizes slip-ring contacts shall comply with the slip-ring connection requirements in accordance with the UL 335, Standard for Cord Reels. Slip-ring testing shall be performed on the complete assembly consisting of the attachment fitting and luminaire or a ceiling-suspended fan support receptacle.

12.7.6 An attachment fitting shall comply with the applicable attachment plug requirements contained in this standard. The attachment plug fitting shall also comply with the UL 514A, Standard for Metallic Outlet Boxes as a component of either a luminaire or ceiling-suspended fan support receptacle.

13 Cord Entry and Strain Relief

13.1 A device intended for connection to flexible cord shall be provided with a means of strain relief so that a pull on the flexible cord will not be transmitted directly to the wiring terminations. Acceptability of the strain relief means shall be determined by the test described in Integrity of Assembly Test, Sections [75](#) or [102](#).

Exception: The strain relief provided on a device intended solely for factory assembly to the conductors of a flexible cord shall be subjected to the Integrity of Assembly Test, Sections [71](#) or [98](#), but is not required to restrict a pull on the flexible cord from being transmitted directly to the wiring terminations when the conductors are terminated as described in [13.2\(a\)](#).

13.2 A device intended solely for factory assembly to the conductors of a flexible cord is to be connected to the conductors by:

- a) Welding, riveting, crimping, or the equivalent, or
- b) Soldering, when an offset or one or more right-angle bends in the conductor are employed so that a pull on the conductor will not be transmitted directly to the connection.

13.3 A device intended for use with Type SP, SPT, or other parallel-conductor flexible cord, shall be provided with one of the following means for securing the individual conductor insulation:

- a) An integral strain relief, not external to the body of the device,
- b) A means for snubbing, or
- c) Space within the device for a strain-relief knot. If a knot is to be used, all surfaces on which the knot may bear shall be smooth and well-rounded.

13.4 The diameter of a round cord-entry hole or the minor axis of an oblong cord-entry hole provided on a device intended for use on Type SP, SPT, or other parallel-conductor flexible cord shall not be longer than 1/4 inch (6.4 mm).

13.5 A metal-covered device intended for connection to a flexible cord shall be provided with an insulating bushing of porcelain, phenolic or cold-molded composition, or other insulating material with equivalent properties.

Exception No. 1: Hard fiber is acceptable for the bushing if the fiber is not less than 3/64 inch (1.2 mm) thick, and it is so formed and secured in place that it will not be affected by ordinary conditions of moisture.

Exception No. 2: If the metal covering (armor) of a device is not in proximity to the cord-entry hole, and the insulating material of which the plug is made serves as a smooth, well-rounded bushing for a flexible cord, a separate insulating bushing is not required.

Exception No. 3: A metal-covered device with a metal cord grip intended specifically for use with a jacketed type of flexible cord, such as Type S or SJ is not required to have an insulating bushing.

14 Spacings

14.1 The spacings maintained through air or over surface shall be a minimum 3/64 inch (1.2 mm) for a device rated 250 V or less, and a minimum 1/8 inch (3.2 mm) for a device rated more than 250 V, between the following:

- a) Uninsulated live parts of opposite polarity;

b) An uninsulated live part and a dead-metal part that is likely to be grounded or exposed to contact by persons when the device is installed as intended, including a metal surface on which the device is mounted in the intended manner or a metal face plate used with a flush receptacle.

Exception No. 1: The grounding terminal of a flush receptacle shall instead comply with the spacing requirements in [31.2.1](#).

Exception No. 2: A self-contained receptacle shall instead comply with the spacing requirements in [44.1](#).

Exception No. 3: A dead-metal screw head, rivet, or the like, which is located in a hole not larger than 9/32 inch (7.1 mm) in diameter and recessed not less than 3/16 inch (4.8 mm) is not considered to be exposed to contact by persons after the device is installed in the intended manner.

14.2 In measuring a spacing, an isolated dead-metal part interposed between live parts of opposite polarity, or between a live part and a grounded or exposed dead-metal part, is considered to reduce the spacing by an amount equal to the dimension of the isolated dead-metal part in the direction of the measurement.

15 Assembly

15.1 General

15.1.1 A device shall be capable of being readily wired as intended.

15.1.2 Electrical contact shall be reliably maintained at any point at which a connection is made between current-carrying parts.

15.1.3 An outlet device shall have live parts protected against exposure to contact by persons when the outlet is assembled and installed as intended.

15.1.4 When internal connections exist in a multiple-outlet device, similar and corresponding contacts of individual outlets shall be connected together.

15.1.5 A device having female contacts shall be constructed so that a standard attachment plug of the same configuration and with maximum length blades is capable of seating properly without exposure of the blades between the plane of the face of the plug and the plane of the rim of the female contact device.

Exception: Exposure of the wide side of the blade for a distance of 1/32 inch (0.8 mm) or less (measured along the length of the blade) is acceptable, and exposure of the narrow side of the blade is acceptable if the exposed area is recessed for a distance not shorter than the length (measured along the blade) of the exposed area.

15.2 Grounding and polarization

15.2.1 A grounding outlet device shall be so constructed that the grounding member of the corresponding attachment plug cannot be inserted by hand into any outlet slot to touch the live contact.

15.2.2 A device consisting of two or more pieces shall be such that polarization cannot be defeated by improper assembly during installation.

15.2.3 A cord connector or current tap having a 1-15R nonpolarized configuration shall not accommodate an attachment plug having polarized blades to the extent that the wider (polarized) blade

can make electrical contact with either outlet device contact. Compliance shall be determined by the test described in Improper Insertion Test, Section [100](#).

15.2.4 A cord connector or current tap having a 1-15R polarized configuration shall not accommodate an attachment plug having polarized blades in other than the intended orientation to the extent that the wider (polarized) blade can make electrical contact with the contact of the narrower (non-polarized) slot. Compliance shall be determined by the test described in Improper Insertion Test, Section [100](#).

15.3 Mating and interchangeability

15.3.1 A general-use device, including any configuration illustrated in Wiring Devices – Dimensional Specifications, ANSI/NEMA WD6, the Standard for Wiring Device Configurations, UL 1681, or the Entertainment Technology Dimensional Requirements for Stage Pin Connectors, ANSI/ESTA E1.24, shall be constructed so that electrical continuity between respective and similarly marked terminals is established automatically when the mating plug and outlet device are connected together.

Exception No. 1: A 2-pole non-polarized device is not required to comply with this requirement

Exception No. 2: A special-purpose device for use in equipment where intermixed connections do not increase the risk of fire, electric shock, injury to persons, or damage to equipment, is not required to comply with this requirement.

15.3.2 An outlet device shall not accommodate an attachment plug other than one that is specifically intended for use with the outlet.

15.3.3 A male or female device that is capable of making a conductive connection with a female or male device of an established general-use design shall be constructed and rated for complete and correct interchangeability with the established design. An established general-use design is considered to include any of the following:

- a) Any of the configurations outlined in Wiring Devices – Dimensional Specifications, ANSI/NEMA WD6;
- b) Any of the configurations outlined in the Standard for Wiring Device Configurations, UL 1681;
- c) Any of the configurations identified in Entertainment Technology Dimensional Requirements for Stage Pin Connectors, ANSI/ESTA E1.24;
- d) Another configuration that is an American National Standard configuration; or
- e) A special-purpose configuration that is acceptable for use in one of the wiring systems that complies with the National Electrical Code, ANSI/NFPA 70.

Exception: A special-purpose receptacle configuration that will not accept any standard general-use plugs shall be permitted to accept a modified general-use plug that will also be accepted by the mating general-use receptacle. (For example, a receptacle for use in a hazardous location that is intended to supply hazardous-location equipment provided with a modified plug that may be used in either an ordinary or hazardous location.)

15.3.4 A male or female device of an established general-use design shall comply with the dimensions, spacings, and the relative arrangement of blade and contact slots required by one of the following:

- a) Wiring Devices – Dimensional Specifications, ANSI/NEMA WD6;
- b) The Standard for Wiring Device Configurations, UL 1681;

- c) Entertainment Technology Dimensional Requirements for Stage Pin Connectors, ANSI/ESTA E1.24; or
- d) Other American National Standard.

15.3.5 Attachment plugs, cord connectors, current taps, and receptacles that have different electrical ratings shall not be interchangeable with one another.

Exception No. 1: A 20-A outlet device is not prohibited from accommodating a 15-A attachment plug for a single and identical voltage rating only.

Exception No. 2: A special-purpose configuration that will not mate with a standard general-use configuration shall be permitted to have multiple current and voltage ratings if the device is intended for installation in facilities where it will be serviced only by qualified personnel, and where the configuration will be used on circuits with one of the device's rated currents, voltages and frequencies throughout the facility.

Exception No. 3: Plugs, cord connectors, and current taps for use on flexible cords, or that are provided with fuses, that have a lower current rating, as described in Exception No. 1 to [192.1](#), are not prohibited from mating with corresponding devices with the standard current rating and the identical voltage rating.

Exception No. 4: Devices of the ANSI/ESTA E1.24 Standard, Type 5 configurations (5T20, 5T30, 5T60 and 5T100) are identified as dual-rated voltage devices ("125 - 250 V"). These configurations are only intended for use on grounded-neutral electrical circuits.

15.3.6 An outlet device having a nongrounding configuration shall not accept a grounding-type attachment plug.

Exception: The locking grounding device illustrated in Standard for Wiring Device Configurations, UL 1681 Figure C1.1 and marked "Hospital Only" shall be permitted to be interchangeable with other nongrounding general-use devices which are not so marked.

15.4 Fuseholders

15.4.1 An enclosure shall be provided for the fuse or fuses in a device intended to accommodate such components.

15.4.2 A fuse enclosure shall reduce the risk of persons unintentionally contacting uninsulated live parts of the fuse and fuseholder.

15.4.3 A fuse enclosure shall confine the effects of a fuse rupture to the interior of the enclosure.

15.4.4 A device intended for use with a branch-circuit type fuse shall not be capable of accommodating a fuse or fuses that have a rating lower than the maximum rating in volts for the device.

15.4.5 In a fusible device, there shall be provision for a fuse in each ungrounded conductor, but there shall be no provision for a fuse in any other conductor.

15.4.6 The construction of a fusible device that has male pins or blades shall be such that the fuse or fuses will not be removable when the pins or blades are in a receptacle.

Exception: A fusible attachment plug having a configuration that is not illustrated in Wiring Devices – Dimensional Specifications, ANSI/NEMA WD6, or in the Standard for Wiring Device Configurations, UL

1681, may be provided with a fuse or fuses which is removable when the pins or blades are in a receptacle when the attachment plug is marked in accordance with Reference No. 12 of [Table 193.1](#).

15.4.7 A fusible outlet device, such as a receptacle or a cord connector, shall not have live parts exposed to contact by persons when a fuse is being removed or replaced.

15.5 Switches

15.5.1 A switch provided as a part of a wiring device shall comply with the Standard for General-Use Snap Switches, UL 20. A switch provided as part of a device intended for factory assembly as a component of end-use equipment shall comply with the Standard for Switches for Appliances – Part 1: General Requirements, UL 61058-1.

ATTACHMENT PLUGS AND INLETS

16 Insulating Materials

16.1 An insulating plate employed for the backing of an inlet shall not be less than 1/32 inch (0.8 mm) thick and shall be moisture-resistant in accordance with [64.1](#) and [64.2](#). Phenolic composition or a similar material is acceptable for the insulating plate. Fiber may be employed if it is not less than 1/16 inch (1.6 mm) thick, is impregnated to resist the absorption of moisture in accordance with [64.1](#) and [64.2](#), and is not depended upon (by itself) to hold contacts or other live parts in place.

17 Enclosure

17.1 General

17.1.1 A general-use attachment plug shall not be provided with more than one cord-outlet hole.

17.1.2 A 2-pole attachment plug shall have a 2-inch (51-mm) or shorter overall length measured from the face of the plug to include any handle grip.

Exception: A 2-5/8 inch (66.7 mm) (maximum) overall length is acceptable for an attachment plug or current tap if the device:

- a) Weighs less than 6 oz (170 g),
- b) Is torsionally balanced about an axis that is perpendicular to the pin face and that is centered between the blades or pins, and
- c) Has a center of gravity located on this axis no further than 1 inch (25.4 mm) from the pin face.

17.1.3 A 50-A attachment plug with a molded phenolic shell enclosing the wiring terminals is not acceptable in an application in which the attachment plug is likely to be subject to severe mechanical abuse.

17.1.4 The body of an inlet employing a combination wire binding/pressure wire-type terminal shall employ integrally formed channels/guides within the body to:

- a) Properly position individual conductor; and
- b) Provide a means to reduce the likelihood of the conductor(s) being displaced from under the terminal ring when conductor(s) are to be installed.

Compliance shall be determined by the Terminal Strength Test, Section [123](#).

17.2 Grip

17.2.1 An attachment plug having a 1-15P configuration for use on parallel or vacuum cleaner (SV, SVO, SVOO, SVT, SVTO, SVTOO, SVE, SVEO, and SVEOO) type flexible cord shall have a surface that facilitates gripping between the thumb and forefinger or some equivalent finger gripping means independent of the cord to provide for easy insertion and withdrawal from an outlet. See Attachment Plug Grip Tests, Section [74](#).

17.3 Face size

17.3.1 The perimeter of the face of an attachment plug having a 1-15P configuration shall encompass an area equal to or larger than that indicated in [Figure 17.1](#).

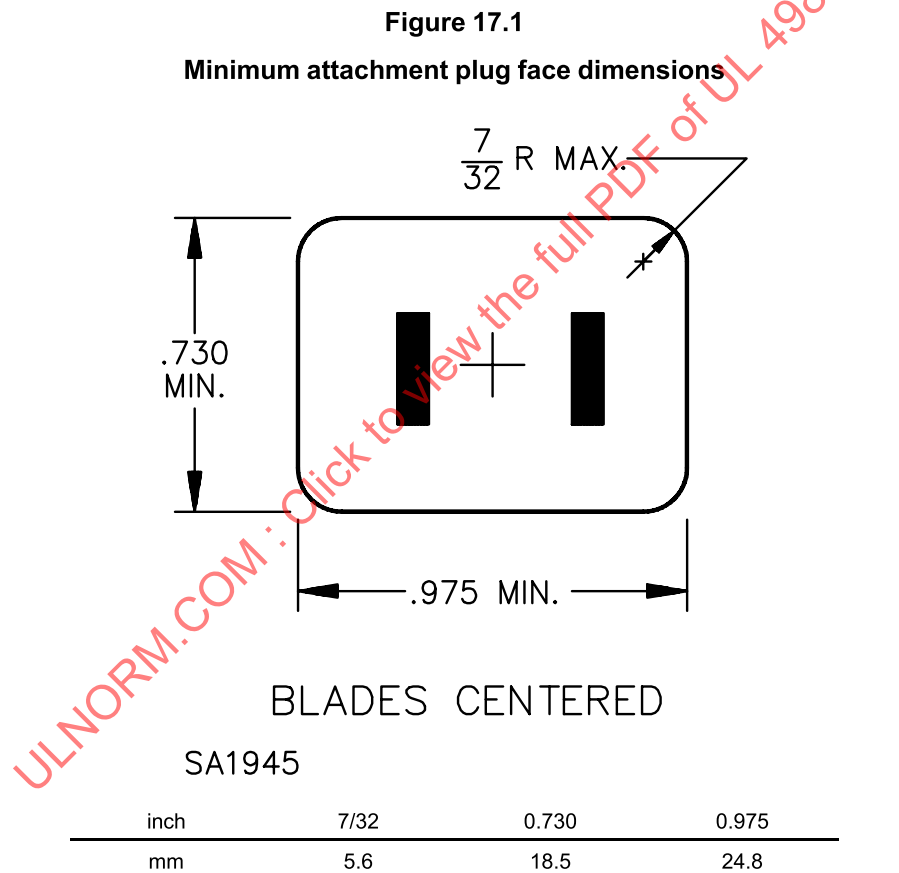

17.4 Configurable Plug

17.4.1 A configurable attachment plug may only be of the Standard for Wiring Devices – Dimensional Specifications, ANSI/NEMA WD6 configurations as shown in [Table 17.1](#).

**Table 17.1
Configurable Attachment Plug Configurations**

ANSI/NEMA WD6 Configuration	No. of Poles	No. of Wires	Ampere, A	Voltage, V
5-30P/5-50P	2	3	30/50	125
6-30P/6-50P	2	3	30/50	250
10-30P/10-50P	3	3	30/50	125/250
14-30P/14-50P/14-60P	3	4	30/50/60	125/250
15-30P/15-50P/15-60P	3	4	30/50/60	250 V, 3-ph
18-30P/18-50P/18-60P	4	4	30/50/60	120/208 V, 3-ph Y

17.4.2 A configurable attachment plug shall comply with all dimensions identified in ANSI/NEMA WD6 for the configuration(s) as specified by the manufacturer.

17.4.3 Blades and associated terminals of a configurable attachment plug shall be uniquely keyed and identified to prevent interchangeability of blades into positions reserved exclusively for either the grounded or grounding terminal and blade/pin profile.

17.4.4 A configurable attachment plug shall have live parts protected against exposure when fully assembled using all essential parts when fully inserted into a mating contact device for each identified configuration.

17.4.5 If a configurable attachment plug identified by the manufacturer includes both grounded configurations ("L"-shaped and flat-shaped) blades and/or configurations for grounding, it shall include all necessary terminals and blade/pin construction for the identified configuration(s).

17.4.6 A configurable attachment plug shall be marked with the electrical rating and blade (ANSI/NEMA) configuration, for each identified configuration. It shall not be possible to misassemble the device with an incorrect rating for the configured blades. In the case where a separable face disk is used, each individual face disk shall be marked with the electrical rating, configuration identifier (i.e. ANSI/NEMA 14-50P), and be individually configured to the specific blade profile for each configuration. Each face disk shall be provided with a mechanical means (i.e. screw) for securement to the plug face enclosure. Adhesives are not permitted.

17.4.7 The enclosure (housing) of a configurable attachment plug that is secured to the terminal housing by a threading action shall not be relied upon to hold the blade/pin terminals in position.

18 Current-Carrying Parts

18.1 The folded-over blades of 15- or 20-A attachment plugs shall be formed from stock that is 0.028 – 0.032 inches (0.71 – 0.81 mm) thick.

Exception: Folded-over blades may be formed from stock less than 0.028 inches (0.71 mm) thick provided the stock is not less than 0.020 inch (0.51 mm) thick and both ends of the blade are securely retained within the body of the device, such that the overall thickness is maintained.

18.2 The profiles of the blades employed in an attachment plug having a 1-15P, 2-15P, 2-20P, 5-15P, 5-20P, 6-15P, or 6-20P configuration shall comply with the dimensional requirements of the Standard for Attachment Plug Blades for Use in Cord Sets and Power-Supply Cords, UL 1659.

19 Grounding and Dead Metal Parts

19.1 The grounding terminal mentioned in [11.6](#) and its corresponding contact shall be conductively connected to the mounting means (yoke or strap) of a flanged inlet and to the armor of an armored attachment plug.

Exception: The conductive connection is not required to be provided in a flanged inlet provided all of the following conditions are met:

- a) *The mounting bracket, yoke, strap, or flange is constructed of an insulating material.*
- b) *The lack of grounding continuity to the mounting means is obvious to the installer.*
- c) *The device is plainly marked in accordance with Reference No. 3 of [Table 193.2](#).*

19.2 For a grounding device, the blade to be used for grounding (G in the figures) shall be longer (see respective figures) than the other blades. For an attachment plug with a nonstandard configuration, the construction of the plug shall be such that, when the plug is inserted into its corresponding receptacle, contact between the grounding blade and the corresponding outlet contact will be made before contact between the other blades and their corresponding contacts.

19.3 A grounding blade or pin of a 15- or 20-A nonlocking type attachment plug shall not contain surface discontinuities that would tend to interfere with insertion or withdrawal from a grounding contact of an outlet device. Abrupt surface transitions such as gaps, steps, offsets, detents, holes or sharp chamfers are specifically prohibited in the following areas shown in [Figure 19.1](#):

- a) The shaft, and
- b) The transition zone between the tip and the shaft which is likely to engage the grounding contact during insertion or withdrawal.

ULNORM.COM : Click to view the PDF of UL 498 2024

Figure 19.1
Grounding pin profiles

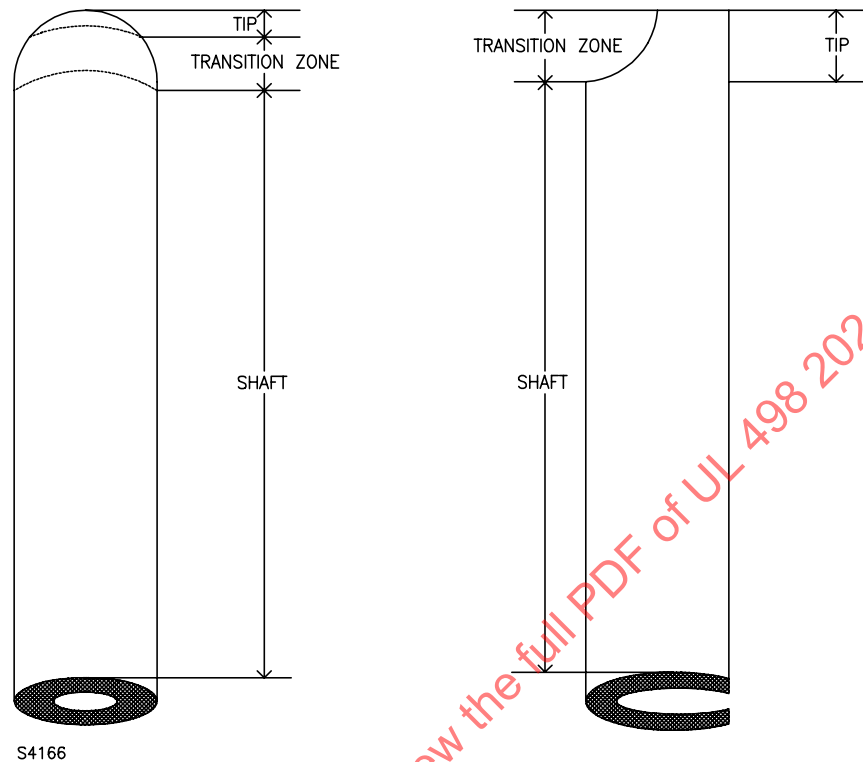

19.4 For a three- or four-pole attachment plug that requires the connection of a grounding conductor, a wiring terminal for the grounding blade or contact is necessary if the device is intended for use with flexible cord.

Exception: If the device is intended for use with armored cable, and if the grounding pin or blade is conductively connected to the armor, no wiring terminal is necessary. If on such a device the armor of the attachment plug is conductively connected to the grounding pin or blade (whether or not a wiring terminal is provided), the electrical connection between the armor and the pin or blade is to be readily visible, or the dead metal of the device is to be marked in accordance with Reference No. 3 of [Table 193.2](#).

19.5 The grounding pin of an attachment plug shall be secured rigidly and perpendicular to the plane of the face. The grounding pin shall not incorporate, or be provided with, a means to pivot, deflect, or bend after being inserted into a mating outlet device. Compliance is checked by visual inspection.

20 Terminals and Leads

20.1 Terminals

20.1.1 A pin-type terminal of an attachment plug intended for field assembly on a flexible cord may be accepted for a current-carrying connection only if it complies with the requirements in Sections [80](#) – [84](#). An attachment plug with pin-type terminals shall have a 1-15P configuration. See Reference No. 5 to [Table 193.1](#).

20.1.2 If an attachment plug is not provided with wire-binding-screw terminals, and employs a soft-rubber compound molded around the blades and attached conductors, the conductors shall be soldered or welded to the blades or attached by means of pressure-wire connectors.

Exception: If tinsel cord is employed, the conductors may be secured to the blades under the heads of rivets or by an equivalent means.

20.2 Leads

20.2.1 Integral grounding and circuit conductor leads of an inlet shall be of copper and shall be:

- a) Type RH or TW wire or an equivalent rubber- or thermoplastic-insulated wire for a general-use device and Type SF, SFF, or an equivalent type of wire for a device intended for use in a fixture, and
- b) Not smaller in size than indicated in [Table 20.1](#).

Table 20.1
Smallest acceptable sizes of inlet leads

Current rating of inlet	Copper circuit leads – AWG (mm ²)	Copper grounding leads – AWG (mm ²)
15A	16 ^a or 14 (1.3 ^a or 2.1)	16 ^a or 14 (1.3 ^a or 2.1)
20	12 (3.3)	12 (3.3)
30	10 (5.3)	10 (5.3)
50	6 (13.3)	10 (5.3)
60	4 (21.1)	10 (5.3)

^a 16 AWG circuit and grounding leads are acceptable only if the inlet is intended for mounting in an appliance.

20.2.2 For an inlet:

- a) An integral grounding pigtail lead shall not be shorter than 6 inches (152 mm), and
- b) Integral circuit leads shall not be shorter than 4 inches (102 mm).

Exception: For an inlet intended for mounting in an electric lighting fixture or appliance, the length of integral leads is not specified.

20.3 Attachment plug and inlet with spring action clamp terminal

20.3.1 An inlet that is provided with spring action clamp terminal shall be provided with a positive means to prevent unintentional separation of the conductor from the terminal and shall comply with the Spring Action Clamp Terminal Pull Test described in Section [91A](#).

20.3.2 An attachment plug that is provided with spring action clamp terminal shall be provided with a positive means to prevent unintentional separation of the conductor from the terminal and shall comply with the Spring Action Clamp Terminal Pull Test described in Section [77A](#).

21 Assembly

21.1 Blades and terminals shall be held securely in place. If they are mounted on a disc of insulating material separate from the rubber compound, the disc shall be:

- a) Of a material acceptable for the mounting of current-carrying parts,
- b) Not less than 1/16 inch (1.6 mm) thick, and
- c) Acceptably secured in the plug.

21.2 Means shall be provided for securely attaching the body of an inlet to the supporting base of an inlet. When assembled, the body shall be restricted from turning with respect to the base.

21.3 A supporting base of an inlet intended for surface mounting shall be provided with no fewer than two holes for mounting screws.

21.4 Live screw heads or nuts on the underside of a base intended for surface mounting shall be spaced 1/2 inch (12.7 mm) or more through air from the mounting surface and staked, upset, or otherwise restricted from loosening.

Exception No. 1: Live parts that are countersunk not less than 1/8 inch (3.2 mm) and then covered with a sealing compound that complies with [8.6.1](#) and [8.6.2](#) are not required to comply with this requirement.

Exception No. 2: Live parts that are countersunk not less than 1/8 inch (3.2 mm) and then covered with a minimum of 1/16 inch (1.6 mm) thick sealing compound, where the sealing compound complies with [8.6.1](#) and [8.6.2](#) and the underside of the supporting base is recessed so that the sealing compound will not contact the surface upon which the receptacle is mounted, are not required to comply with this requirement.

21.5 An attachment plug intended for connections to radio-antenna, ground, or both shall be such that the blades cannot be inserted to touch the live contacts of a conventional outlet device not intended for use with such a plug. See [Figure 21.1](#) for an example of a radio-antenna plug configuration.

ULNORM.COM : Click to view the full PDF of UL 498 2024

Figure 21.1
Example of a radio-antenna plug configuration

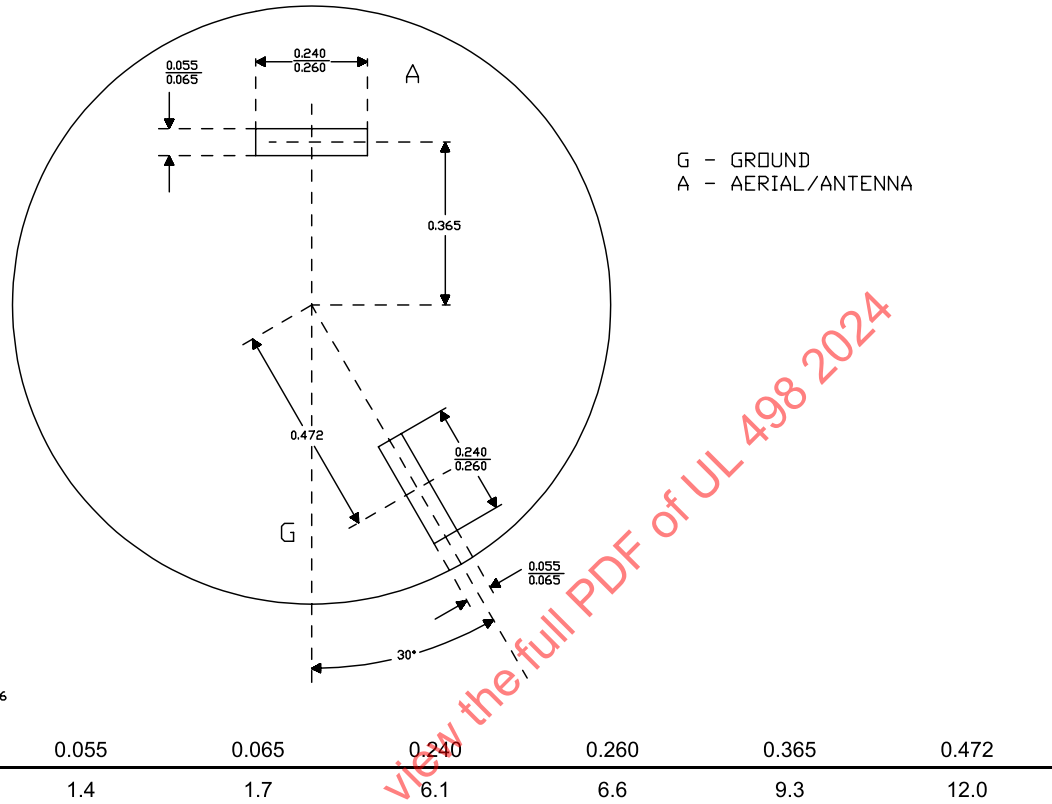

ULNORM.COM : Click to view the full PDF of UL 498 2024

22 Weatherproof Type

22.1 Fiber and similar absorptive materials shall not be used in a weatherproof attachment plug.

22.2 A lead wire provided as part of a weatherproof attachment plug, and intended to be exposed after installation, shall be:

- a) A stranded RH, RHW, TW, or an equivalent type of wire,
- b) Not smaller than 14 AWG (2.1 mm²), and
- c) Not less than 4-1/2 inches (114 mm) long.

CORD CONNECTORS

23 Enclosure

23.1 General

23.1.1 A cord connector having a 1-15R configuration intended for use on general-use cord sets employing parallel or vacuum cleaner (SV, SVT, SVO, SVE, SVEO, SVEOO, SVOO, SVTO, and SVTOO) type flexible cord shall have their contacts and other live parts spaced not less than 1/4 inch (6.35 mm) behind the face when measured from the plane of each slot opening through air and over insulating surfaces. The plane of the slot opening is defined as follows:

- a) For slot openings that are bevelled to facilitate the entrance of a plug blade, the plane of the slot opening is that plane nearest the face of the device in which the minor dimensions of the slots are no more than twice the value specified for the 1-15R slot configuration, as shown in [Figure 23.1](#).
- b) For slot openings without bevels, the plane of the slot opening is the plane of the cord connector face.

Figure 23.1
Typical slot cross section (with bevel)

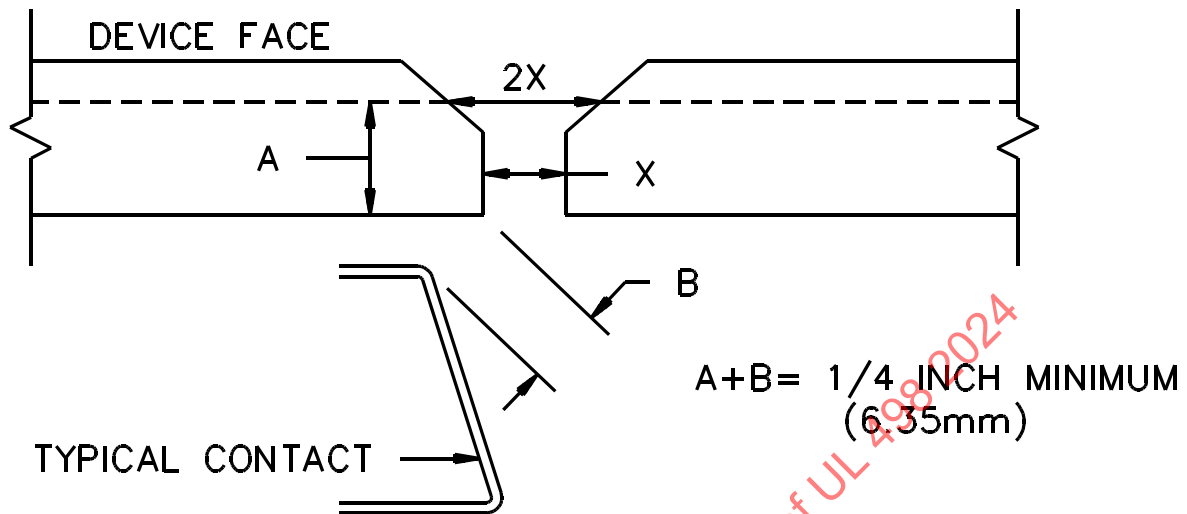

SA1815

23.2 Face size

23.2.1 The outlet face of a cord connector having a 5-20R or 6-20R configuration shall obstruct the insertion of an attachment plug having a 6-20P or 5-20P configuration, respectively, to the extent that the indicated devices cannot be mated by deliberate manual force including manipulation to deflect the ground pin to the outside of the face when attempting to insert the line blades. The obstruction shall:

- a) Have the minimum size and shape indicated as the shaded portions of [Figure 23.2](#). The "A" dimension shall be at least 0.531 inch (13.5 mm) for a cord connector molded of a material having a hardness of 90 or greater, and at least 0.625 inch (15.9 mm) for a cord connector molded of a material having a hardness of less than 90, where the material hardness is measured using the "A" scale on a Shore Durometer; and
- b) Be coplanar with the face or recessed by not more than 3/32 inch (2.4 mm).

Figure 23.2

Faces of outlet devices showing locations and minimum dimensions of obstructions

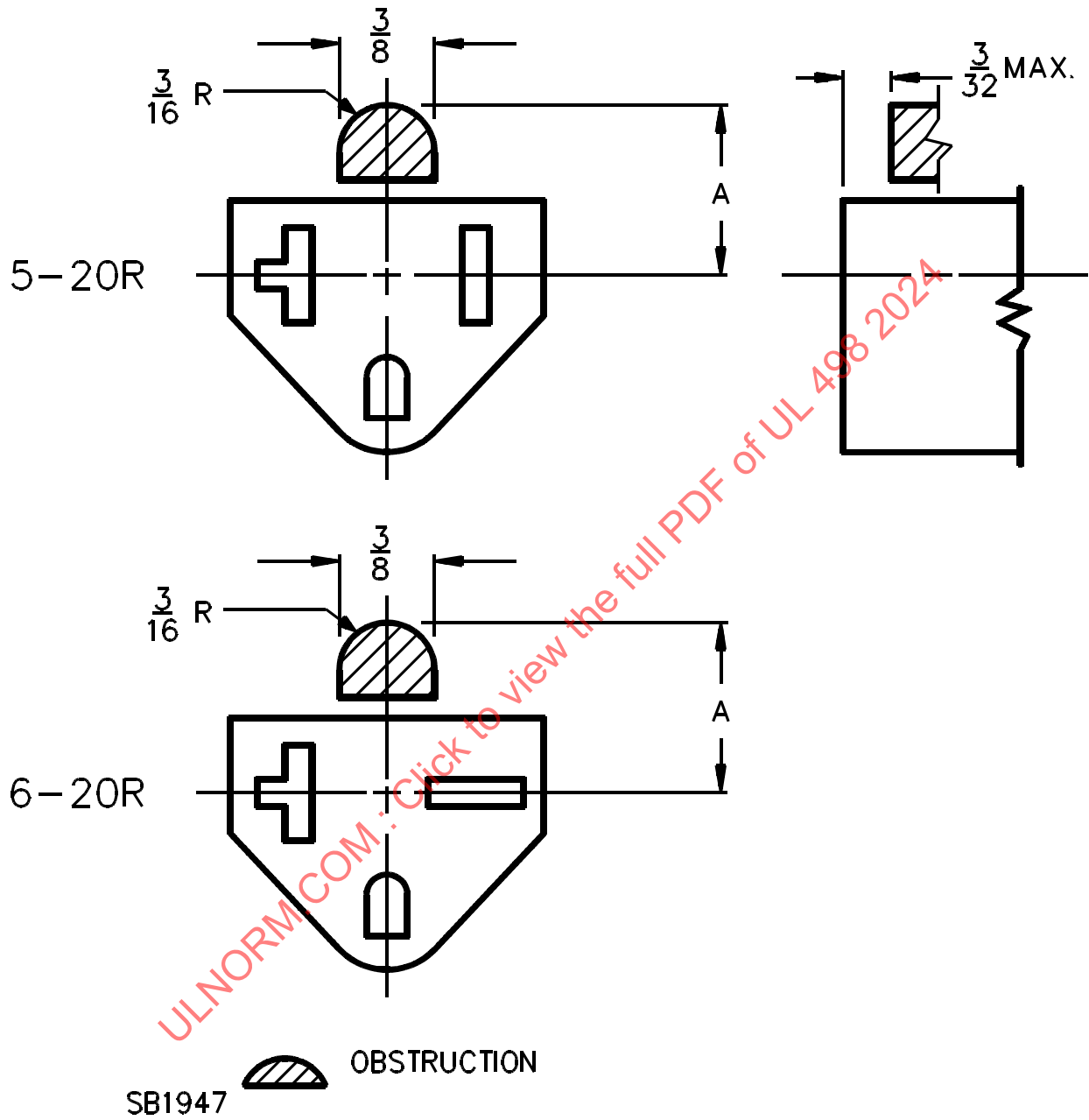

23.2.2 The outlet face of a cord connector having a 1-15R configuration shall have a perimeter that encompasses an area equal to or larger than that indicated in [Figure 23.3](#), and shall obstruct the insertion of an attachment plug having a 5-15P configuration to the extent that the grounding attachment plug cannot be mated by deliberate manual force including manipulation to deflect the ground pin to the outside of the face when attempting to insert the line blades. The obstruction shall:

- a) Have the minimum size and shape indicated as the shaded portions of [Figure 23.2](#). The "A" dimension shall be at least 0.531 inch (13.5 mm) for a cord connector molded of a material having a hardness of 90 or greater, and at least 0.625 inch (15.9 mm) for a cord connector molded of a material having a hardness of less than 90, where the material hardness is measured using the "A" scale on a Shore Durometer; and
- b) Be coplanar with the face or recessed by not more than 3/32 inch (2.4 mm).

Figure 23.3
Minimum outlet face dimensions

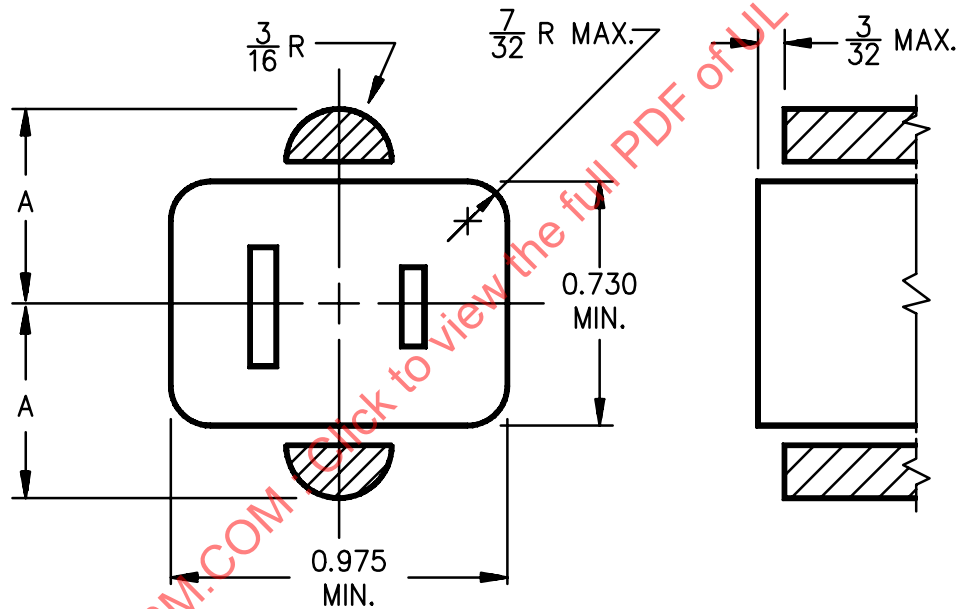

SA1946

inch	3/32	3/16	7/32	0.730	0.975
mm	2.4	4.8	5.6	18.5	24.8

Dimension A inch (mm)	Shore durometer hardness (scale A)
0.625 (15.9)	less than 90
0.531 (13.5)	90 or more

24 Grounding and Dead Metal Parts

24.1 The grounding terminal mentioned in [11.6](#) and [24.2](#) and its corresponding contact shall be conductively connected to the armor of an armored cord connector.

24.2 For a three- or four-pole cord connector that requires the connection of a grounding conductor, a wiring terminal for the grounding blade or contact is necessary if the device is intended for use with flexible cord.

Exception: If the device is intended for use with armored cable, and if the grounding contact is conductively connected to the armor, a wiring terminal is not required. If on such a device the armor of the cord connector is conductively connected to the grounding contact (whether or not a wiring terminal is provided), the electrical connection between the armor and the contact is to be readily visible, or the dead metal of the device is to be marked in accordance with Reference No. 11 of [Table 193.3](#).

24.3 The grounding contact in a grounding-type cord connector shall be located and formed so that the path of electrical continuity to the grounding pin or blade of a mating attachment plug is completed before continuity is established between any other contact and its respective pin or blade on the attachment plug. This grounding path shall be substantial when the attachment plug is properly seated in the cord connector.

25 Terminals

25.1 A pin-type terminal of a cord connector intended for field assembly on a flexible cord may be accepted for a current-carrying connection only if it complies with the requirements in Sections [105](#) – [109](#). A cord connector with pin-type terminals shall have a 1-15R configuration.

25A Cord Connector with Spring Action Clamp Terminal

25A.1 A cord connector that is provided with spring action clamp terminal shall be provided with a positive means to prevent unintentional separation of the conductor from the terminal and shall comply with the Spring Action Clamp Terminal Pull Test described in Section [99A](#).

26 Assembly

26.1 General

26.1.1 In a cord connector, an assembly screw, rivet, or the like that is visible and is electrically connected to any live part shall be located in a hole not larger than 9/32 inch (7.1 mm) in diameter and recessed not less than 3/16 inch (4.8 mm).

26.1.2 When internal connections exist in a multiple-outlet cord connector, similar and corresponding contacts of individual outlets shall be connected together.

26.1.3 A cord connector shall not accommodate an attachment plug other than one that is specifically intended for use with the outlet.

26.1.4 The construction of a cord connector intended for use on a household appliance shall be such that the set of pins described in [55.1](#) and [Table 55.1](#) cannot, without distortion or forcing, be made to seat properly in the female contacts.

Exception: A conventional flatiron or appliance plug for use on a household heating appliance is not precluded by this requirement.

26.1.5 A general-use cord connector including a table tap, shall be constructed with only one hole or breakout for the cord (not for through-cord wiring).

26.1.6 A cord connector shall not be provided with more than three outlets and shall not employ any screw shell outlets.

26.1.7 A table tap shall not be provided with an assembly-screw hole extending through the device from front to back, a mounting-screw hole, or other means by which it can be mounted permanently. If binding-screw terminals are employed, only one set shall be provided, and there shall be means provided for gaining access to them.

26.1.8 A cord connector shall comply with the requirements in [13.1](#) – [13.5](#) for strain relief, bushings, and cord grips.

26.2 Outlet separation

26.2.1 Cord connectors having two or more outlets of the 1-15R configuration shall provide for the full insertion of attachment plugs in all outlets simultaneously using plugs having the face size indicated in [Figure 17.1](#).

RECEPTACLES

26A General

26A.1 15 and 20 amp straight blade receptacles are suitable for use in an ambient temperature up to 50°C.

27 Insulating Materials

27.1 A surface-type 50-A receptacle with an enclosure of insulating material is not acceptable for use in an application in which the receptacle is likely to be subject to severe mechanical abuse.

27.2 An insulating plate employed for the backing of a receptacle used to form all or a part of the enclosure shall employ insulating materials that comply with [8.2.1](#) – [8.4.1](#). The material shall not be less than 1/32 inch (0.8 mm) thick and shall be moisture-resistant in accordance with [64.1](#) and [64.2](#). Fiber may be employed in an insulating plate if it is not less than 1/16 inch (1.6 mm) thick, is impregnated to resist the absorption of moisture in accordance with [64.1](#) and [64.2](#) and is not depended upon (by itself) to hold contacts or other live parts in place.

28 Enclosure

28.1 If the dimensions of a 1-15R, 2-15R, or 2-20R receptacle face are smaller than shown in [Figure 28.1](#) for the particular configuration used, the receptacle face shall not project more than 3/16 inch (4.8 mm) beyond the flush mounting surface for which it is intended, or less than 3/32 inch (2.4 mm) when the mounting surface is of metal.

28.2 The body of a receptacle employing a combination wire binding/pressure wire-type terminal shall employ integrally formed channels/guides within the body to:

- a) Properly position individual conductor; and
- b) Provide a means to reduce the likelihood of the conductor(s) being displaced from under the terminal ring when conductor(s) are to be installed.

Compliance shall be determined by the Terminal Strength Test, Section [123](#).

Figure 28.1
Dimensional limits for the face of a receptacle

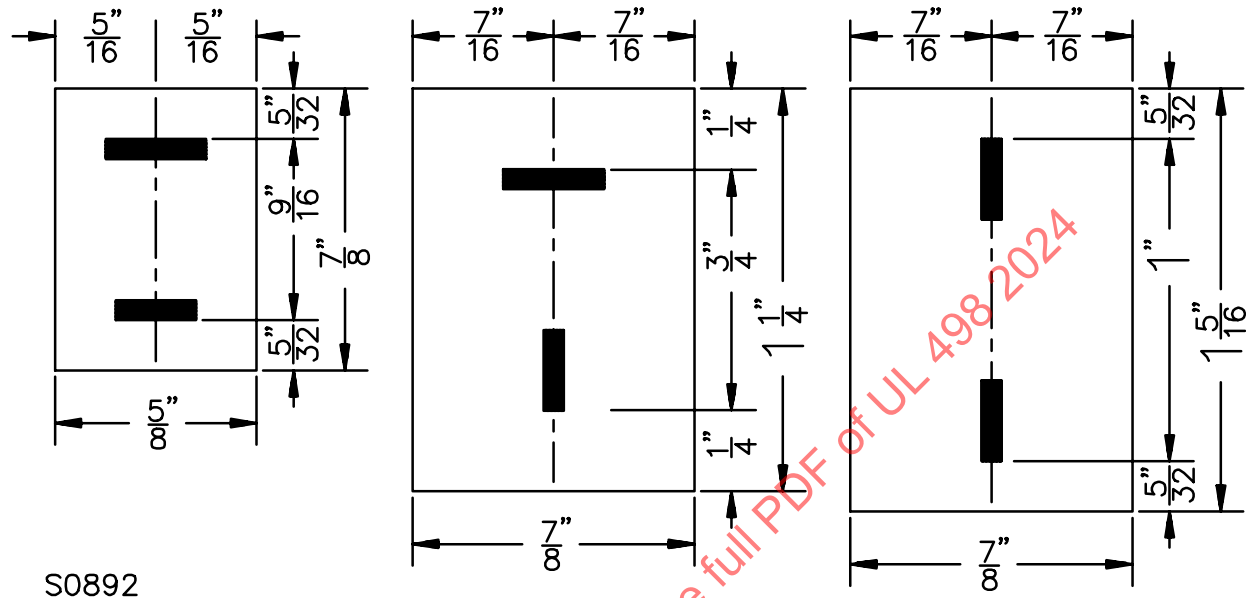

S0892

inch	5/32	1/4	5/16	9/16	5/8	3/4	7/8	1	1-1/4	1-5/16
mm	4.0	6.4	7.9	14.3	15.9	19.1	22.2	25.4	31.8	33.3

29 Grounding and Dead Metal Parts

29.1 General

29.1.1 The requirement in [11.6](#) does not preclude the acceptance of a flush receptacle that does not include a grounding terminal provided:

- a) The receptacle can be used only in a metallic wiring system (such as with rigid metal conduit, electrical metallic tubing, surface metal raceway, or the like); and
- b) The connection between the grounding contact and the metal raceway is automatically completed as the receptacle is installed.

29.1.2 The grounding terminal mentioned in [11.6](#) and its corresponding contact shall be conductively connected to the mounting means (yoke or strap) of a receptacle.

Exception No. 1: The conductive connection is not required to be provided in an appliance or fixture outlet or a flush receptacle if all the following conditions are met:

- a) *The mounting means is formed of an insulating material;*
- b) *The lack of grounding continuity to the mounting means is obvious to the installer; and*
- c) *The device is marked in accordance with Reference No. 8 of [Table 193.4](#).*

Exception No. 2: The conductive connection is not required to be provided in an isolated ground receptacle if it is marked in accordance with Reference No. 9 of [Table 193.4](#).

Exception No. 3: The conductive connection is not required to be provided in surface-mount receptacles, self-contained receptacles, or any other receptacles for use only with a nonmetallic wiring system (not adaptable to a metallic wiring system).

29.1.3 The grounding contact in a grounding-type receptacle shall be located and formed so that the path of electrical continuity to the grounding pin or blade of a mating attachment plug is completed before continuity is established between any other contact and its respective pin or blade on the attachment plug. This grounding path shall be substantial when the attachment plug is properly seated in the receptacle.

29.1.4 Only one grounding terminal shall be provided on a grounding-type receptacle. The grounding terminal of a grounding-type receptacle shall only accept a single grounding conductor and shall not serve as a connection point for two separate grounding conductors.

Exception No. 1: A surface-mount or self-contained receptacle of the 5-15R configuration may be provided with two grounding terminals to permit through-wiring of the equipment grounding conductor if the removal of the device also disconnects the power to the downstream circuits.

Exception No. 2: Each outlet module of an interchangeable or modular receptacle may be provided with its own grounding terminal.

29.1.5 "Push-In" grounding terminations shall not be used.

29.2 Flush receptacles

29.2.1 All dead-metal parts of a flush receptacle, including the grounding terminal, shall not have sharp edges or points that may be forced against the wiring during installation in an outlet box.

29.2.2 A flush receptacle shall be constructed so that a metal flush plate will be bonded to the metal outlet box or the receptacle grounding terminal when the receptacle is installed as intended.

Exception: A receptacle with an integral nonmetallic flush plate that cannot be replaced with a metal flush plate is not required to comply with this requirement.

30 Terminals and Leads

30.1 General

30.1.1 The line wiring terminals of a receptacle intended for mounting in an outlet box shall be located or protected so that, upon installation, they will not be forced against the wiring in the box. See also [29.2.1](#).

Exception: Exposed wiring terminals on a receptacle intended solely for mounting in a box intended to be supported by rigid conduit may be located on the back of the receptacle.

30.1.2 A receptacle shall provide a substantial clearance between each terminal and the metal of a standard box of the type in which it is intended to be installed.

30.2 Push-in terminals

30.2.1 A push-in terminal may be accepted for a current-carrying connection in a 5-15R or 6-15R receptacle only if it meets the tests described in Pullout Test, Section [132](#), and Temperature Test, Section [133](#), for factory-wired devices and Sections [134](#) – [137](#) for field-wired devices.

30.2.2 A flush receptacle having a 5-15R or 6-15R configuration employing "Push-In" line terminations intended for field wiring shall accept a 14 AWG (2.1 mm²) solid conductor and shall reject a 12 AWG (3.3 mm²) solid conductor. The opening provided for the conductor shall reject a No. 48 drill rod, 0.076 ±0.0003 inch (1.981 ±0.0076 mm) in diameter. The rod is to be applied with 5 lbf (22 N). The receptacle shall be marked in accordance with Reference No. 23 of [Table 193.4](#).

30.2.3 A "Push-In" terminal shall not be used with stranded wire.

30.2.4 A flush receptacle having a 5-15R or 6-15R configuration employing "Push-In" terminations for field wiring and provided with a means to release the conductors shall not permit entry of a 14 AWG (2.1 mm²) or larger solid conductor into any opening in the insulating body provided to engage the release mechanism behind the plane of the mounting means. The wire release means, if provided, shall be subjected to the tests in Temperature Test, Push-In Terminals, Section [137](#).

30.2.5 A release mechanism shall be located or guarded so that it cannot be unintentionally actuated during installation. The release mechanism may be guarded by recessing, ribs, barriers, or the like.

30.3 Pin-type or insulation-displacement terminals

30.3.1 A pin-type or insulation-displacement terminal of a fixture, equipment, or appliance outlet intended for factory assembly on copper conductors may be accepted for a current-carrying connection only if it complies with the requirements described in the Heat Cycling and Vibration Tests, Section [151](#).

30.4 Open wiring on insulators

30.4.1 Circuit wires entering a receptacle intended for open wiring on insulators:

- a) Shall not be closer than 1/2 inch (12.7 mm) to the surface wired over if the device is rated 250 V less, and
- b) Shall not be closer than 1 inch (25.4 mm) to the surface wired over if the device is rated more than 250 V.

30.5 Leads

30.5.1 Integral grounding- and supply-conductor leads of a receptacle shall be of copper and shall be:

- a) Type RH or TW wire or an equivalent rubber- or thermoplastic-insulated wire for a general-use receptacle and Type SF, SFF, or an equivalent type of wire for a fixture type of receptacle, and
- b) Not smaller in size than indicated in [Table 30.1](#) for a receptacle that employs other than a separable terminal assembly and not smaller than 12 AWG for a receptacle that employs a separable terminal assembly.

Table 30.1
Smallest acceptable sizes of receptacle leads

Current rating of receptacle	Copper supply leads – AWG (mm ²)	Copper grounding leads – AWG (mm ²)
15A	16 ^a or 14 (1.3 ^a or 2.1)	16 ^a or 14 (1.3 ^a or 2.1)
20	12 (3.3)	12 (3.3)
30	10 (5.3)	10 (5.3)
50	6 (13.3)	10 (5.3)
60	4 (21.1)	10 (5.3)

^a 16 AWG supply and grounding leads are acceptable only if the receptacle is intended for mounting in an appliance.

30.5.2 For a general-use receptacle:

- a) An integral grounding pigtail lead shall not be shorter than 6 inches (152 mm), and
- b) Integral supply leads shall not be shorter than 4 inches (102 mm).

Exception: For an appliance or fixture receptacle outlet, the length of integral leads is not specified.

30.6 Separable terminal assembly

30.6.1 A separable terminal assembly shall consist of permanently attached pins or tabs located on the body of the receptacle and shall be capable of receiving a special purpose connector with leads for connection to the branch circuit.

30.6.2 A separable terminal assembly shall:

- a) Be provided with a mechanical means such as a lock, latch or similar means, which prohibits unintentional separation when in the mated condition, and shall comply with the Latching Mechanism Test described in Section [159](#),
- b) Be reliably keyed by a physical or mechanical means to maintain correct polarity and voltage consistent with the intended use. The terminals shall be marked identifying the terminal positions and identifying the unidentified (hot), grounded (neutral) and grounding terminal. Color-coding of integral wire leads is an acceptable means of terminal identification,
- c) Be reliably keyed to limit interconnection to only like voltage, and
- d) The grounding-conductor terminals shall connect before mating supply conductor terminals connect when two or more connectors are mated as intended. During disconnection of mating connectors, the supply-conductor terminals shall disconnect before the grounding-conductor terminal disconnects.

30.6.3 The contacts of the special purpose connector, when not mated to a receptacle, shall not be accessible to contact by the probe in [Figure 9.1](#).

30.7 Receptacle with spring action clamp terminal

30.7.1 A receptacle that is provided with spring action clamp terminal shall be provided with a positive means to prevent unintentional separation of the conductor from the terminal and shall comply with the Spring Action Clamp Terminal Pull Test described in Section [128A](#).

30.8 Receptacles intended for copper-clad aluminum conductor

30.8.1 Unless conductor size (AWG) is otherwise specified on the device, individual package label, or instruction sheet, terminals of 15 A and 20 A receptacles intended for copper-clad aluminum conductor shall be capable of being assembled to 10 AWG solid copper-clad aluminum conductor. Compliance shall be checked by the Terminal Strength Test, Section [123](#) for receptacles employing:

- a) Wire-binding screws alone or in combination with push-in terminals;
- b) Pressure-wire terminals; or
- c) Wire-binding screws in combination with pressure-wire terminals.

31 Assembly

31.1 General

31.1.1 When internal connections exist in a multiple-outlet receptacle, similar and corresponding contacts of individual outlets shall be connected together.

31.1.2 For a duplex receptacle that includes a break-off jumper between the two halves of a set of unidentified terminals, to provide for a separation that would enable the connection of each outlet to one of the respective ungrounded conductors, and to the grounded conductor of a 3-wire branch circuit, a minimum spacing, based on the maximum potential of the branch circuit (for example, 250 V for 125 V receptacle), is to exist between parts of opposite polarity that are present when the jumper is removed for such use. See [14.1](#).

31.1.3 A receptacle having a 1-15R configuration that is intended for fixed installation in a wiring system that is in accordance with the National Electrical Code, ANSI/NFPA 70, shall be of the polarized type shown in the 1-15R configuration illustrated in Wiring Devices – Dimensional Specifications, ANSI/NEMA WD6.

31.1.4 A receptacle shall be such that the blades of a radio-attachment plug cannot be inserted to touch the contacts of a receptacle other than one specifically intended for use with such a plug. See [Figure 21.1](#) for an example of a radio-antenna plug configuration.

31.2 Flush receptacles

31.2.1 The grounding terminal of a grounding-type flush receptacle shall be spaced at least 1/4 inch (6.4 mm) from any ungrounded live part (associated with other than a white grounded terminal) exposed to contact by a grounding conductor in the outlet box. Live parts accessible from within the cavity of an outlet box are considered exposed to contact by a grounding conductor if they can be contacted by the probe illustrated in [Figure 31.1](#). The spacings shall be measured through air and over both insulating and conductive surfaces with the receptacle wired as intended with the maximum anticipated conductor size. They shall be measured from any point on the grounding terminal that may contact the clamped grounding conductor as in the case of a wire-binding screw terminal, or from any point on the perimeter of an opening to receive a grounding conductor in the case of an enclosed terminal.

Figure 31.1
Flat probe

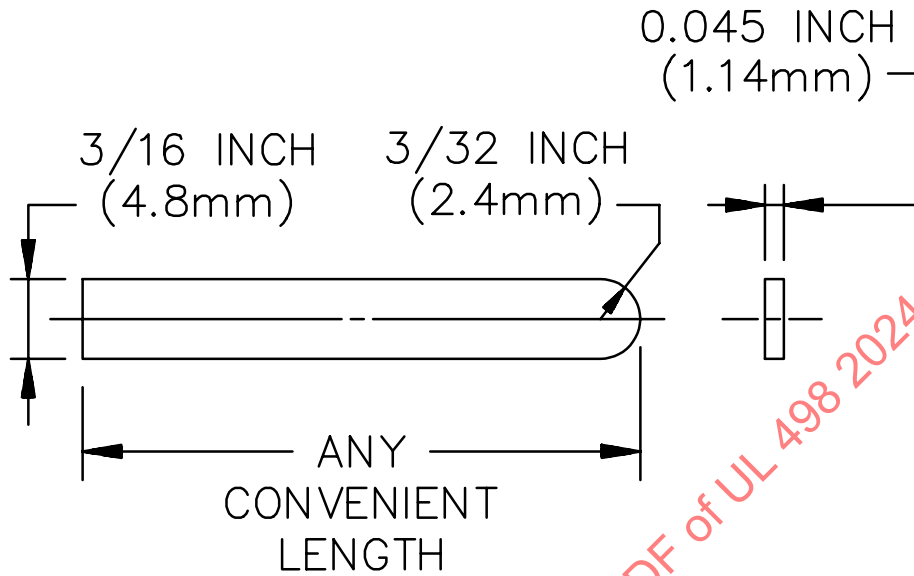

PA215A

inch	0.045	3/32	3/16
mm	1.14	2.4	4.8

31.2.2 A flush receptacle shall be provided with means for mounting in a standard flush-device box or on a standard outlet box cover.

31.2.3 A yoke, strap, or mounting ears shall be formed of steel that is a minimum 0.040 inch (1.02 mm) thick.

Exception No. 1: The minimum thickness at scores or perforations provided so that extension plaster ears may be broken off when not needed is not required to comply with this requirement.

Exception No. 2: If nonferrous metal is used, it shall provide mechanical strength and rigidity equal to that of 0.040 inch thick (1.02 mm) steel.

31.2.4 A steel yoke, strap, or mounting ears shall be protected against corrosion by a copper-plated or oxidized finish.

Exception: A zinc or cadmium coating not less than 0.00015 inch (0.0038 mm) thick as determined in accordance with the requirements in the Standard for Metallic Outlet Boxes, UL 514A, or other coatings determined to possess equivalent corrosion protection properties are not required to comply with this requirement.

31.2.5 A screw provided with a receptacle for use in mounting the device to an outlet box or other enclosure shall not project more than 7/8 inch (22.2 mm) beyond the strap or cover and shall have a flat or blunt end. The end of the screw may have thread-cleaning slots or grooves but shall not have any burrs, fins, or other sharp edges that could damage wiring.

31.2.6 A receptacle that is provided with an adjustable screw, or screws if more than one is provided, or any other adjustment hardware shall not project more than 7/8 inch (22.2 mm) beyond the plane of the mounting yoke where secured to the outlet box. The end of the adjustable hardware shall have a flat or blunt end. If an adjustment screw is provided, it may have thread-cleaning slots or grooves but shall not have any burrs, fins, or other sharp edges that could damage wiring.

31.2.7 The adjustment means of an adjustable receptacle shall not permit installation in an application where the front edge of the installed outlet box, plaster ring, extension ring, or outlet box extender is set back from the finished surface (e.g. drywall) more than a 1/4 inch (6.0 mm). Compliance is checked by measurement.

31.3 Surface-mount receptacles

31.3.1 In a surface receptacle, an assembly screw, rivet, or the like that is visible and is electrically connected to any live part shall be located in a hole not larger than 9/32 inch (7.1 mm) in diameter and recessed not less than 3/16 inch (4.8 mm).

31.3.2 Means shall be provided for securely attaching the body of a surface-mount receptacle to the supporting base. When assembled, the body shall be restricted from turning with respect to the base.

31.3.3 A supporting base intended for surface mounting shall be provided with no fewer than two holes for mounting screws.

31.3.4 Live screw heads or nuts on the underside of a base intended for surface mounting shall be spaced 1/2 inch (12.7 mm) or more through air from the mounting surface and staked, upset, or otherwise restricted from loosening.

Exception No. 1: Live parts that are countersunk not less than 1/8 inch (3.2 mm) and then covered with a minimum of 1/8 inch (3.2 mm) thick sealing compound that complies with [8.6.1](#) and [8.6.2](#) are not required to comply with this requirement.

Exception No. 2: Live parts that are countersunk not less than 1/8 inch (3.2 mm) and then covered with a minimum of 1/16 inch (1.6 mm) thick sealing compound, where the sealing compound complies with [8.6.1](#) and [8.6.2](#) and the underside of the supporting base is recessed so that the sealing compound will not contact the surface upon which the receptacle is mounted, are not required to comply with this requirement.

32 Flush Plates

32.1 A flush plate provided as an integral part of a receptacle shall comply with the requirements for flush plates in the Standard for Metallic Outlet Boxes, UL 514A, or the Standard for Nonmetallic Outlet Boxes, Flush-Device Boxes, and Covers, UL 514C.

33 Self-Grounding Receptacles

33.1 A self-grounding receptacle shall not be rated greater than 30 A or 150 V to ground and shall comply with the Fault Current Test, Section [130](#).

34 Isolated-Ground Receptacles

34.1 An isolated-ground receptacle shall be identified in accordance with the marking and instruction requirements for isolated-ground receptacles specified in Reference No. 9 of [Table 193.4](#).