



UL 489

STANDARD FOR SAFETY

Molded-Case Circuit Breakers, Molded-Case Switches and Circuit-Breaker Enclosures

ULNORM.COM : Click to view the full PDF of UL 489 2025

ULNORM.COM : Click to view the full PDF of UL 489 2025

ULSE INC. COPYRIGHTED MATERIAL – NOT AUTHORIZED FOR FURTHER REPRODUCTION OR DISTRIBUTION WITHOUT PERMISSION FROM ULSE INC.

UL Standard for Safety for Molded-Case Circuit Breakers, Molded-Case Switches and Circuit-Breaker Enclosures, UL 489

Fourteenth Edition, Dated March 7, 2025

SUMMARY OF TOPICS

This new Fourteenth Edition of ANSI/UL 489 dated March 7, 2025, incorporates the following:

Addition of consideration of programmable component errata; [K14.4](#)

Addition of energy reducing maintenance setting; [2.28](#), [12.6](#) – [12.8](#), [32.6](#)

Addition of requirements for generator transfer; Section [80](#), Annex [B](#)

Miscellaneous editorial updates including renumbering and reformatting to align with current style

The requirements are substantially in accordance with Proposal(s) on this subject dated December 2, 2022 and March 1, 2024.

All rights reserved. No part of this publication may be reproduced, stored in a retrieval system, or transmitted in any form by any means, electronic, mechanical photocopying, recording, or otherwise without prior permission of ULSE Inc. (ULSE).

ULSE provides this Standard "as is" without warranty of any kind, either expressed or implied, including but not limited to, the implied warranties of merchantability or fitness for any purpose.

In no event will ULSE be liable for any special, incidental, consequential, indirect or similar damages, including loss of profits, lost savings, loss of data, or any other damages arising out of the use of or the inability to use this Standard, even if ULSE or an authorized ULSE representative has been advised of the possibility of such damage. In no event shall ULSE's liability for any damage ever exceed the price paid for this Standard, regardless of the form of the claim.

Users of the electronic versions of UL's Standards for Safety agree to defend, indemnify, and hold ULSE harmless from and against any loss, expense, liability, damage, claim, or judgment (including reasonable attorney's fees) resulting from any error or deviation introduced while purchaser is storing an electronic Standard on the purchaser's computer system.

No Text on This Page

ULNORM.COM : Click to view the full PDF of UL 489 2025



Association of Standardization and Certification
NMX-J-266-ANCE-2025
Sixth Edition



CSA Group
CSA C22.2 No. 5:25
Fifth Edition



ULSE Inc.
UL 489
Fourteenth Edition

Molded-Case Circuit Breakers, Molded-Case Switches, and Circuit-Breaker Enclosures

March 7, 2025

ULNORM.COM : Click to view the full PDF of UL 489 2025



ANSI/UL 489-2025



ULSE INC. COPYRIGHTED MATERIAL – NOT AUTHORIZED FOR FURTHER
REPRODUCTION OR DISTRIBUTION WITHOUT PERMISSION FROM ULSE INC.

Commitment for Amendments

This Standard is issued jointly by the Association of Standardization and Certification (ANCE), the Canadian Standards Association (operating as "CSA Group"), and ULSE Inc. (ULSE). Comments or proposals for revisions on any part of the standard may be submitted to ANCE, CSA Group, or ULSE at anytime. Revisions to this Standard will be made only after processing according to the standards development procedures of ANCE, CSA Group, and ULSE. CSA Group and ULSE will issue revisions to this Standard by means of a new edition or revised or additional pages bearing their date of issue. ANCE will incorporate the same revisions into a new edition of the standard bearing the same date of issue as the CSA Group and ULSE pages.

© 2025 ANCE

Rights reserved in favor of ANCE.

ISBN 978-1-4883-4491-6 © 2025 Canadian Standards Association

All rights reserved. No part of this publication may be reproduced in any form whatsoever without the prior permission of the publisher.

This Standard is subject to review within five years from the date of publication, and suggestions for its improvement will be referred to the appropriate committee. To submit a proposal for change, please send the following information to inquiries@csagroup.org and include "Proposal for change" in the subject line: Standard designation (number); relevant clause, table, and/or figure number; wording of the proposed change; and rationale for the change.

To purchase CSA Group Standards and related publications, visit CSA Group's Online Store at www.csagroup.org/store/ or call toll-free 1-800-463-6727 or 416-747-4044.

© 2025 ULSE Inc. All rights reserved.

Our Standards for Safety are copyrighted by ULSE Inc. Neither a printed nor electronic copy of a Standard should be altered in any way. All of our Standards and all copyrights, ownerships, and rights regarding those Standards shall remain the sole and exclusive property of ULSE Inc.

This ANSI/UL Standard for Safety consists of the Fourteenth Edition. The most recent designation of ANSI/UL 489 as an American National Standard (ANSI) occurred on March 7, 2025. ANSI approval for a standard does not include the Cover Page, Transmittal Pages, Title Page (front and back), or the Preface.

The Department of Defense (DoD) has adopted UL 489 on January 18, 1985. The publication of revised pages or a new edition of this Standard will not invalidate the DoD adoption.

NEMA (National Electrical Manufacturers Association) has adopted UL 489 (US Requirements) on August 11, 1999 as NEMA Standard AB1. The publication of revised pages or a new edition of this Standard will not invalidate the NEMA adoption.

Comments or proposals for revisions on any part of the Standard may be submitted to ULSE at any time. Proposals should be submitted via a Proposal Request in the Collaborative Standards Development System (CSDS) at <https://csds.ul.com>.

For information on ULSE Standards, visit <https://www.shopulstandards.com>, call toll free 1-888-853-3503 or email us at ClientService@shopULStandards.com.

CONTENTS

PREFACE 13

INTRODUCTION

1 Scope 15
 2 Definitions 15
 3 Components 21
 4 Units of Measurement 22
 5 Reference Publications 22

MOLDED CASE CIRCUIT BREAKERS

CONSTRUCTION

6 All Types 22
 6.1 General 22
 6.2 Corrosion protection 23
 6.3 Cases – Insulating material 23
 6.4 Current-CARRYING PARTS 23
 6.5 Operating mechanism 28
 6.6 Spacings 30
 7 Current-Limiting Circuit Breakers 35
 8 Instantaneous-Trip Circuit Breakers 35
 9 Circuit Breaker and Ground-Fault Circuit-Interrupters 35
 9.1 General 35
 9.2 Supervisory circuit 36
 10 Circuit Breakers with Equipment Ground-Fault Protection 36
 11 Integrally Fused Circuit Breakers, High-Fault Protectors, and High-Fault Modules 36
 12 Adjustable Circuit Breakers 37
 13 Heating, Air Conditioning, and Refrigeration (HACR) Circuit Breakers 38
 14 Remotely-Operated Circuit Breakers 38
 15 Switching Duty (SWD) Rated Circuit Breakers 38
 16 400 Hz Rated Circuit Breakers 38
 17 Draw-Out Circuit Breakers 38
 18 Series-Connected Circuit Breakers 39
 19 Interchangeable-Trip Circuit Breakers 39
 20 High-Intensity-Discharge (HID) Type Circuit Breakers 39
 21 Circuit Breakers for Use with 16 or 18 AWG Wire 39
 22 4-Pole Circuit Breakers 39
 23 Circuit Breakers and Surge Protective Devices 39
 24 Special Purpose Not for General Use Circuit Breakers 40
 25 Circuit Breakers with Electronic Trip Units 40

TESTS

26 Standard Circuit Breakers 40
 26.1 General 40
 26.2 Calibration tests 46
 26.3 Overload test 52
 26.4 Temperature test 54
 26.5 Endurance test 59
 26.6 Calibration test 62

26.7	Interrupting test	62
26.8	Trip-out at 200 percent current test.....	71
26.9	Dielectric voltage-withstand test.....	71
26.10	Miscellaneous tests.....	72
26.11	High available fault current test sequence	73
27	Current-Limiting Circuit Breakers	79
27.1	General.....	79
27.2	Calibration test	79
27.3	Interrupting and let-through measurement test	79
27.4	Trip-out test.....	84
27.5	Dielectric voltage-withstand test.....	84
27.6	Interpretation of results.....	84
28	Instantaneous-Trip Circuit Breakers	84
29	Circuit Breaker and Ground-Fault Circuit-Interrupters	85
29.1	General.....	85
29.2	Circuit breaker test sequences.....	85
29.3	High available fault-current circuits.....	91
29.4	Ground-fault circuit-interrupter tests	92
30	Circuit Breakers with Equipment Ground-Fault Protection.....	95
30.1	General.....	95
30.2	Circuit breaker test sequences.....	95
30.3	High available fault current circuits tests	101
30.4	Ground fault protection tests	102
31	Integrally Fused Circuit Breakers, High-Fault Protectors, and High-Fault Modules	102
32	Adjustable Circuit Breakers	106
32.1	General.....	106
32.2	Adjustable current setting (I_r)	106
32.3	Short-time delay	106
32.4	Instantaneous pick-up setting	107
32.5	Ground-fault trip response.....	107
32.6	Energy-reducing maintenance setting	107
33	Heating, Air Conditioning, and Refrigeration (HACR) Circuit Breakers	107
34	Remotely-Operated Circuit Breakers.....	107
35	Switching Duty (SWD) Rated Circuit Breakers	107
36	400 Hz Rated Circuit Breakers	108
37	Draw-Out Circuit Breakers	108
37.1	Electrical continuity test.....	108
37.2	Dielectric voltage-withstand test.....	109
38	Series-Connected Circuit Breakers	109
38.1	General.....	109
38.2	Selection of test samples.....	109
38.3	Test procedure	111
38.4	Closing test	114
38.5	Interrupting test	114
38.6	Intermediate interrupting test	114
38.7	Trip-out test.....	115
38.8	Other functionality calibration test	115
38.9	Dielectric voltage-withstand test.....	115
38.10	Interpretation of test results	116
39	Interchangeable-Trip Circuit Breakers	116
40	High-Intensity-Discharge (HID) Type Circuit Breakers	116
41	Circuit Breakers for Use with 16 or 18 AWG Wire	116
41.1	General.....	116
41.2	Circuit breaker test sequences.....	117
41.3	High available fault current test sequence.....	117
41.4	Thermal withstand sequence	117

42	4-Pole Circuit Breakers	118
43	Joints with Insulators	118
44	Circuit Breakers and Surge Protective Devices	118
45	Special Purpose Not for General Use Circuit Breakers	118

RATINGS

46	General	118
----	---------------	-----

MARKINGS

47	General	120
	47.1 Details	120
	47.2 Terminations	125
	47.3 Interrupting ratings	126
	47.4 Special markings	126
48	Current-Limiting Circuit Breakers	127
49	Instantaneous-Trip Circuit Breakers	127
50	Circuit Breaker and Ground-Fault Circuit-Interrupters	128
51	Circuit Breakers with Equipment Ground-Fault Protection	128
52	Integrally Fused Circuit Breakers and High Fault Protectors	128
53	Adjustable Circuit Breakers	129
54	Heating, Air Conditioning, and Refrigeration (HACR) Circuit Breakers	129
55	Remotely-Operated Circuit Breakers	129
56	Switching Duty (SWD) Rated Circuit Breakers	130
57	400 Hz Rated Circuit Breakers	130
58	Draw-Out Circuit Breakers	130
59	Series-Connected Circuit Breakers	130
60	Interchangeable-Trip Circuit Breakers	130
61	High-Intensity-Discharge (HID) Type Circuit Breakers	131
62	Rating Plugs	131
63	Circuit Breakers for Use with 16 or 18 AWG Wire	131
64	4-Pole Circuit Breakers	131

MOLDED CASE SWITCHES

CONSTRUCTION

65	All types	131
	65.1 General	131
	65.2 Corrosion protection	131
	65.3 Cases – Insulating material	132
	65.4 Current-carrying parts	132
	65.5 Operating mechanism	132
	65.6 Spacings	132
66	Draw-Out Switches	132

PERFORMANCE

67	General	133
	67.1 Details	133
	67.2 Temperature test	136
	67.3 Overload test	137
	67.4 Endurance test	137
	67.5 Dielectric voltage-withstand test	137

67.6	Miscellaneous tests	137
67.7	Withstand test	137
68	Draw-Out Switches.....	142
68.1	General.....	142
68.2	Electrical continuity test.....	142

RATINGS

69	General	142
----	---------------	-----

MARKINGS

70	General	143
----	---------------	-----

ACCESSORIES

CONSTRUCTION

71	General	146
71.1	General details	146
71.2	Installation	146
71.3	Mounting.....	148
71.4	Field wiring.....	148
71.5	Strain relief.....	148
71.6	Spacings.....	149
72	Shunt Trip Release Devices	149
73	Undervoltage-Trip Release Devices.....	150
74	Overvoltage-Trip Release Devices.....	150
75	Electrical Operators.....	150
76	Alarm and Auxiliary Switches	150
77	Mechanical Interlock.....	151
78	Lock-Off Device	151
79	Lock-On Device	151
80	Generator Transfer (For use in Canada Only).....	152

PERFORMANCE

81	General	152
82	Shunt-Trip Release Devices.....	154
82.1	Temperature.....	154
82.2	Overvoltage test	154
82.3	Operation test.....	154
82.4	Endurance test.....	154
82.5	Dielectric voltage-withstand test.....	154
83	Undervoltage-Trip Release Devices.....	155
83.1	Temperature.....	155
83.2	Overvoltage test	155
83.3	Operation test.....	155
83.4	Endurance test	156
83.5	Dielectric voltage-withstand test.....	156
83.6	Contact closing test.....	156
84	Overvoltage-Trip Release Devices.....	156
84.1	Temperature.....	156
84.2	Overvoltage test	156
84.3	Operation test.....	157

84.4	Endurance test	157
84.5	Dielectric voltage-withstand test.....	157
85	Electrical Operators.....	157
85.1	Endurance test	157
85.2	Dielectric voltage-withstand test.....	158
86	Alarm and Auxiliary Switches	158
86.1	Temperature.....	158
86.2	Overload test.....	159
86.3	Endurance test	160
86.4	Dielectric voltage-withstand test.....	160
87	Mechanical Interlock	160
88	Lock-Off Device	160
89	Lock-On Device	161

RATINGS

90	General	161
----	---------------	-----

MARKINGS

91	General	161
----	---------------	-----

ENCLOSURES

CONSTRUCTION

92	General	163
93	Provision for Locking	164
94	Connections to Wiring Systems	164
95	Ventilation.....	165
96	External Operating Mechanism.....	166
97	Cases – Insulating Material	167
98	Current-Carrying Parts.....	167
99	Spacings	168
99.1	General.....	168
99.2	Wiring space	168
100	Equipment Grounding Terminals.....	172
101	Enclosures Suitable for Use as Service Equipment (For use in US and Mexico)	173
101.1	General.....	173
101.2	Disconnecting means.....	173
101.3	Provision for grounding	173
101.4	Provision for bonding	176
101.5	Provisions for ground-fault protection	176
101.6	Provisions for service equipment.....	178
102	Enclosures Suitable for Use as Service Equipment (for use in Canada)	179
102.1	General.....	179
102.2	Ground fault protection.....	182
102.3	Barriers	182

PERFORMANCE (SHORT-CIRCUIT CURRENT RATINGS)

103	General	184
104	Sample Selection	185
105	Sample Preparation.....	185
106	Line Connections.....	185

107	Load Connections	185
108	Meter-Mounting Equipment	186
109	Short-Circuit Procedure	186
110	Short-Circuit Tests	187
111	Interpretation of Results	187
112	Dielectric Voltage-Withstand Test.....	187

RATINGS

113	General.....	188
-----	--------------	-----

MARKINGS

114	General.....	188
115	Position Indication	190
116	Short-Circuit Current Rating	190
117	Terminations.....	191
118	Environmental-Type Designations.....	192
119	Neutral Assemblies.....	192
120	Back-Fed Hold-Down Kit.....	193
121	Service Equipment Use (For use in US and Mexico).....	193
122	Service Equipment Use (for use in Canada Only).....	194
123	Ground-Fault Protection.....	195
124	Permanence of Marking	195
125	Installation Instructions for the Testing of Ground-Fault Protection of Equipment	195

Annex A (Informative) Standards for Components

A1	Component Standards	197
----	---------------------------	-----

Annex B (Normative) Referenced Standards

B1	Referenced Standards	198
----	----------------------------	-----

Annex C (Normative) Circuit Calibration and Instrumentation Test Circuits

C1	Instrumentation.....	200
C2	Calibration of Galvanometers	200
C3	Alternating Current Circuits 10,000 A and Less	201
C4	Alternating Current Circuits Greater than 10,000 A	203
C5	Recovery Voltage – AC	204
C6	Direct Current Circuits.....	205

Annex D (Informative) French and Spanish Translations and Markings

D1	General.....	207
----	--------------	-----

Annex E (For Canada Only – Informative) Guidelines for Ground Fault Protection Equipment

E1	General.....	208
----	--------------	-----

Annex F (Informative) Recommended Symbols and Abbreviations for the Marking of All Products

F1 General 210
 F2 Symbols 210
 F3 Abbreviations 212

ANNEX G (Normative) – MOLDED-CASE CIRCUIT BREAKERS, MOLDED-CASE SWITCHES, AND CIRCUIT-BREAKER ENCLOSURES (MARINE USE) FOR USE UNDER USCG ELECTRICAL SYSTEMS REGULATIONS SUBCHAPTER S (33 CFR, PART 183) AND USCG ELECTRICAL ENGINEERING REGULATIONS SUBCHAPTER J (46 CFR, PARTS 110 – 113)

INTRODUCTION

G1 Scope 214
 G2 Glossary 214

CONSTRUCTION

G3 General 214

PERFORMANCE

G4 General 215
 G5 Vibration Test 215
 G6 Shock Test 216
 G7 Short-Circuit Test 217
 G8 Ignition-Protected Devices Test 217

MARKINGS

G9 General 217

ANNEX H (Normative) – MOLDED-CASE CIRCUIT BREAKERS, MOLDED-CASE SWITCHES, AND CIRCUIT-BREAKER ENCLOSURES (NAVAL USE)

INTRODUCTION

H1 Scope 218

PERFORMANCE

H2 Vibration Test 218
 H2.1 General 218
 H2.2 Resonance frequency test 218
 H2.3 Variable frequency test 219
 H3 Calibration Test 220
 H3.1 200 percent calibration test 220
 H3.2 100 percent calibration test 220

MARKINGS

H4 General 220

ANNEX I (Normative) – MOLDED-CASE CIRCUIT BREAKERS AND MOLDED-CASE SWITCHES FOR USE WITH BATTERY POWER SUPPLIES

INTRODUCTION

11	Scope.....	221
12	Glossary.....	221

CONSTRUCTION

13	General.....	221
----	--------------	-----

PERFORMANCE

14	General.....	221
15	Calibration Test.....	221
16	Overload Test.....	222
17	Endurance Test.....	222
18	Interrupting Test.....	222
19	Dielectric Voltage-Withstand Test.....	222
110	High-Available-Fault-Current Testing.....	223
111	Short Circuit Current Withstand Test.....	223
112	Contact Opening Test.....	223

RATINGS

113	General.....	223
-----	--------------	-----

MARKINGS

114	General.....	223
-----	--------------	-----

ANNEX J (Normative) – CLASSIFIED CIRCUIT BREAKERS FOR USE WITH SPECIFIED PANELBOARDS AS AN ALTERNATE FOR SPECIFIED CIRCUIT BREAKERS**INTRODUCTION**

J1	Scope.....	225
J2	Glossary.....	225

CONSTRUCTION

J3	General.....	225
J4	Handle Ties.....	225

PERFORMANCE

J5	General.....	225
J6	Interrupting Test.....	226

MARKINGS

J7	Details.....	226
----	--------------	-----

ANNEX K (Normative) – MOLDED-CASE CIRCUIT BREAKERS AND MOLDED-CASE SWITCHES WITH SOFTWARE IN PROGRAMMABLE COMPONENTS

K1	Scope	227
K2	Glossary.....	227
K3	Risk Analysis	229
K4	Process Definition	230
K5	Qualification of Software Tools	230
K6	Software Design	230
K7	Critical and Supervisory Sections of Software	231
K8	Product Interface	232
K9	User Interfaces	232
K10	Software Analysis and Testing.....	232
	K10.1 Software analysis	232
	K10.2 Software testing	233
K11	Documentation.....	234
	K11.1 User documentation	234
	K11.2 Software plan	234
	K11.3 Risk analysis approach and results	234
	K11.4 Configuration management plan	234
	K11.5 Programmable system architecture.....	234
	K11.6 Programmable component and software requirements specification.....	235
	K11.7 Software design documentation	235
	K11.8 Analysis and test documentation.....	235
K12	Off-the-Shelf (OTS) Software	235
K13	Software Changes and Document Control	236
K14	Identification	236

ANNEX L (normative) – ADDITIONAL TESTS FOR CIRCUIT BREAKERS WITH ELECTRONIC OVERCURRENT PROTECTION

L1	Scope.....	238
L2	Tests	238
	L2.1 Electromagnetic compatibility (EMC) tests	238
	L2.2 Suitability for multiple frequencies	239
	L2.3 Dry heat test.....	239
	L2.4 Damp heat test.....	239
	L2.5 Temperature variation cycles at a specified rate of change.....	239
L3	General Test Conditions.....	239
	L3.1 General.....	239
	L3.2 Electromagnetic compatibility tests	239
L4	Immunity Tests	240
	L4.1 Harmonic currents	240
	L4.2 Electrostatic discharges	241
	L4.3 Radiated radio-frequency electromagnetic fields	241
	L4.4 Electrical fast transient/burst (EFT/B)	242
	L4.5 Surges.....	242
	L4.6 Conducted disturbances induced by radio-frequency fields (common mode).....	242
	L4.7 Current dips	242
L5	Emission Tests	243
	L5.1 Harmonics	243
	L5.2 Voltage fluctuations.....	243
	L5.3 Conducted RF disturbances (150 kHz – 30 MHz)	243
	L5.4 Radiated RF disturbances (30 MHz – 1 GHz).....	244
L6	Suitability for Multiple Frequencies.....	244
	L6.1 General.....	244
	L6.2 Test conditions	244
	L6.3 Test procedure	244
	L6.4 Test results.....	244

L7	Dry Heat Test	245
	L7.1 Test procedure	245
	L7.2 Test results.....	245
	L7.3 Verification of overload releases	245
L8	Damp Heat Test	245
	L8.1 Test procedure	245
	L8.2 Verification of overload releases	245
L9	Temperature Variation Cycles at a Specified Rate of Change.....	246
	L9.1 Test conditions	246
	L9.2 Test procedure	246
	L9.3 Test results.....	246
	L9.4 Verification of overload releases	246

ANNEX M – ELECTROMAGNETIC COMPATIBILITY (EMC) – REQUIREMENTS AND TEST METHODS FOR CIRCUIT BREAKERS

M1	General	267
M2	Immunity.....	268
	M2.1 General.....	268
	M2.2 Electrostatic discharges	270
	M2.3 Radiated radio-frequency electromagnetic fields	270
	M2.4 Electrical fast transients/bursts (EFT/B).....	270
	M2.5 Surges	270
	M2.6 Conducted disturbances induced by radio-frequency fields (common mode)	271
M3	Emission.....	271
	M3.1 General.....	271
	M3.2 Conducted RF disturbances (150 kHz – 30 MHz)	272
	M3.3 Radiated RF disturbances (30 MHz – 1000 MHz).....	272

ANNEX N (normative) – MOLDED-CASE CIRCUIT BREAKERS WITH ADDITIONAL MOTOR OVERLOAD PROTECTION

INTRODUCTION

N1	Scope	279
----	-------------	-----

CONSTRUCTION

N2	General.....	279
----	--------------	-----

PERFORMANCE

N3	Motor Overload Calibration Test.....	279
----	--------------------------------------	-----

MARKINGS

N4	General.....	280
----	--------------	-----

PREFACE

This is the harmonized ANCE, CSA Group, and ULSE standard for Molded-Case Circuit Breakers, Molded-Case Switches, and Circuit-Breaker Enclosures. It is the sixth edition of NMX-J-266-ANCE, the fifth edition of CSA C22.2 No. 5, and the fourteenth edition of UL 489. This edition of NMX-J-266-ANCE supersedes the previous edition published on April 22, 2019. This edition of CSA C22.2 No. 5 supersedes the previous edition published October, 2016. This edition of UL 489 supersedes the previous edition published on April 22, 2019.

This harmonized standard was prepared by the Association of Standardization and Certification (ANCE), CSA Group, and ULSE. The efforts and support of the Technical Harmonization Subcommittee, 121A, Molded Case Circuit Breakers on the Harmonization of Electrotechnical Standards of the Nations of the Americas (CANENA), are gratefully acknowledged.

This Standard is considered suitable for use for conformity assessment within the stated scope of the standard.

The present Mexican standard was developed by the CT CDI Control y Distribución Industrial from the Comité de Normalización de la Asociación de Normalización y Certificación, A.C., CONANCE, with the collaboration of the circuit breaker manufacturers and users.

This Standard was reviewed by the CSA Subcommittee on Molded Case Circuit Breakers, Molded Case Switches and Circuit Breaker Enclosures under the jurisdiction of the CSA Technical Committee on Industrial Products and the CSA Strategic Steering Committee on Requirements for Electrical Safety, and has been formally approved by the CSA Technical Committee. This standard has been developed in compliance with Standards Council of Canada requirements for National Standards of Canada. It has been published as a National Standard of Canada by CSA Group.

Application of Standard

Where reference is made to a specific number of samples to be tested, the specified number is to be considered a minimum quantity.

Note: Although the intended primary application of this Standard is stated in its scope, it is important to note that it remains the responsibility of the users of the standard to judge its suitability for their particular purpose.

Level of Harmonization

This Standard uses the IEC format but is not based on, nor is it considered equivalent to, an IEC standard.

This Standard is published as an equivalent standard for ANCE, CSA Group, and UL.

An equivalent standard is a standard that is substantially the same in technical content, except as follows: Technical national differences are allowed for codes and governmental regulations as well as those recognized as being in accordance with NAFTA Article 905, for example, because of fundamental climatic, geographical, technological, or infrastructural factors, scientific justification, or the level of protection that the country considers appropriate. Presentation is word for word except for editorial changes.

Interpretations

The interpretation by the standards development organization of an identical or equivalent standard is based on the literal text to determine compliance with the standard in accordance with the procedural rules of the standards development organization. If more than one interpretation of the literal text has been

identified, a revision is to be proposed as soon as possible to each of the standards development organizations to more accurately reflect the intent.

ULNORM.COM : Click to view the full PDF of UL 489 2025

INTRODUCTION

1 Scope

1.1 The requirements of this Standard applies to molded-case circuit breakers, circuit breaker and ground-fault circuit-interrupters, fused circuit breakers, high-fault protectors, and high-fault modules. These circuit breakers are specifically intended to provide service entrance, feeder, and branch circuit protection in accordance with the National Installation Codes in Annex B, Ref. No. 1. This Standard also covers instantaneous-trip circuit breakers (circuit interrupters) specifically intended for use as part of a combination motor controller in accordance with the National Installation Codes in Annex B, Ref. No. 1.

1.2 This Standard applies to molded-case switches and fused molded-case switches.

1.3 This Standard applies to devices rated at 1000 volts ac and 1500 volts dc or less and 6000 amperes or less.

1.4 The devices referenced in [1.1](#) and [1.2](#) are intended for installation in an overall enclosure or as parts of other devices such as panelboards. The acceptability of the combination will be determined when the complete product is investigated.

1.5 This Standard applies to circuit-breaker enclosures and accessory devices intended for use with the devices described in [1.1](#) and [1.2](#).

1.6 This Standard does not apply to low-voltage power circuit breakers covered in Annex B, Ref. No. 3 and Ref. No. 4 or supplementary protectors covered in Annex B, Ref. No. 5.

1.7 This Standard contains supplements covering the requirements for molded-case circuit breakers for:

- a) Marine Use;
- b) Naval Use;
- c) Uninterruptible Power Supply Use;
- d) Classified Circuit Breakers;
- e) Software in Programmable Components;
- f) Additional Tests for Circuit Breakers with Electronic Overcurrent Protection;
- g) Electromagnetic Compatibility (EMC) – Requirements and Test Methods for Circuit Breakers; and
- h) Molded-Case Circuit Breakers with Additional Motor Overload Protection.

2 Definitions

2.1 For the purposes of this Standard, the following definitions apply.

2.2 ACCESSORIES – A device or devices that perform a secondary or minor duty as an adjunct or refinement to the primary or major duty of a molded case product.

2.3 ADJUSTABLE CIRCUIT BREAKER – A circuit breaker that has adjustable time/current tripping characteristics. These may include:

- a) Inverse-time (such as continuous current, long time, and/or short time);
- b) Instantaneous; and
- c) Ground-fault.

2.4 ADJUSTABLE INSTANTANEOUS RELEASE (TRIP) – That part of an overcurrent trip element that can be adjusted to trip a circuit breaker instantaneously at various values of current within a predetermined range of currents.

2.5 ALARM SWITCH – A switch that operates to open or close a circuit upon the automatic opening of the molded case product with which it is associated.

2.6 AMBIENT-COMPENSATED CIRCUIT BREAKER – A circuit breaker in which means are provided for partially or completely neutralizing the effect of ambient temperature upon the tripping characteristics.

2.7 AMBIENT TEMPERATURE – The temperature of the surrounding medium that comes in contact with the circuit breaker or switch. For an enclosed device, it is the temperature of the medium outside the enclosure.

2.8 AUXILIARY SWITCH – A switch that operates to open or close an auxiliary (control) circuit upon the opening, closing, or tripping of the molded-case product with which it is associated.

2.9 CALIBRATION – The factory adjustment of the release mechanism of a circuit breaker to make the circuit breaker perform in accordance with its prescribed characteristics.

2.10 CALIBRATION TEST – Verifies the tripping characteristics of a circuit breaker.

2.11 CIRCUIT BREAKER – A device designed to open and close a circuit by nonautomatic means, and to open the circuit automatically on a predetermined overcurrent, without damage to itself when properly applied within its rating.

2.12 CIRCUIT BREAKER AND GROUND-FAULT CIRCUIT-INTERRUPTER – A device that performs all normal circuit breaker functions and provides personnel protection by functioning to de-energize a circuit within an established period of time when a current to ground exceeds the values established for a Class A device as required by the National Installation Codes in Annex B, Ref. No. 1.

2.13 CIRCUIT BREAKER AND SURGE PROTECTIVE DEVICE – A device that performs all normal circuit breaker functions and provides protection for repeated limiting of specified transient-voltage surges on 50 or 60 Hz power circuits not exceeding 600 V.

2.14 CIRCUIT BREAKER ENCLOSURE – An enclosure intended to house a single, multipole, or two single-pole molded-case products.

2.15 CIRCUIT BREAKERS WITH GROUND-FAULT PROTECTION OF EQUIPMENT – Circuit breakers that perform all normal circuit breaker functions and also trip when a fault current to ground exceeds a predetermined value.

2.16 CLASS I GROUND-FAULT SENSING AND RELAYING EQUIPMENT – Equipment that does not incorporate means to prevent opening of the disconnecting means at high levels of fault current.

2.17 CLASS II GROUND-FAULT SENSING AND RELAYING EQUIPMENT – Equipment that incorporates means to prevent initiation of opening of the disconnecting device if the fault current exceeds the contact-interrupting capability of the disconnecting device.

2.18 CLASS CTL CIRCUIT BREAKER – One that, because of its size or configuration, in conjunction with a Class CTL panelboard, prevents more circuit breaker poles from being installed than the number for which the assembly is intended and rated.

2.19 CLOSE-OPEN OPERATION – A close operation followed immediately by an open operation without purposely delayed action. The letters "CO" signify this operation.

2.20 COMMON TRIP CIRCUIT BREAKER – A multipole circuit breaker constructed so that all poles will open when any one or more poles open automatically.

2.21 CROSS-OVER CURRENT – The current of a fused circuit breaker at which the function of the fuse coincides with the operation of the trip mechanism of the circuit breaker, i.e., where the fuse clearing time curve crosses the circuit breaker trip characteristic curve.

2.22 CURRENT-LIMITING CIRCUIT BREAKER – One that does not employ a fusible element and, when operating within its current-limiting range, limits the let-through I^2t to a value less than the I^2t of a 1/2-cycle wave of the symmetrical prospective current.

2.23 CURRENT-LIMITING RANGE – The rms symmetrical prospective currents between the threshold current and the maximum interrupting rating current.

2.24 CURRENT SETTING (I_r) – The rms current an adjustable circuit breaker is set to carry continuously without tripping. It is normally expressed as a percentage of the rated current and is adjustable.

2.25 DIELECTRIC VOLTAGE-WITHSTAND TEST – Determines the ability of the insulating materials and spacings used to withstand overvoltages without breakdown under specified conditions.

2.26 DRAWOUT-MOUNTED CIRCUIT BREAKER – An assembly of a circuit breaker together with a supporting structure constructed so that the circuit breaker is supported and can be moved to either the main circuit connected or disconnected position without the necessity of removing connections or mounting supports. The structure includes both self-supporting circuit terminals and an interlocking means that permits movement of the circuit breaker between the main circuit connected and disconnected positions only when the circuit breaker contacts are in the open position.

2.27 ELECTRICAL OPERATOR – An electrical controlling device which is used to operate the mechanism of a circuit breaker in order to open, close, and if applicable, reset the circuit breaker or switch.

2.28 ENERGY-REDUCING MAINTENANCE SETTING – A selectable function of the trip unit intended to reduce the clearing time of a circuit breaker thereby reducing the energy during an arc fault event.

2.29 ENDURANCE TEST – Determines compliance with a specified number of mechanical and electrical operations.

2.30 EXTERNAL OPERATING MECHANISM – A mechanism that engages the handle of a circuit breaker and provides a manual means for operating the circuit breaker.

2.31 FIXED INSTANTANEOUS RELEASE (TRIP) – That part of an overcurrent release element which contains a nonadjustable means that is set to trip a circuit breaker instantaneously above a predetermined value of current.

2.32 FRAME – An assembly consisting of all parts of a circuit breaker except an interchangeable trip unit.

2.33 **FRAME SIZE** – A term applied to a group of circuit breakers of similar physical configuration. Frame size is expressed in amperes and corresponds to the largest ampere rating available in the group. The same frame size designation may be applied to more than one group of circuit breakers.

2.34 **FUSED CIRCUIT BREAKER** – A circuit breaker that contains replaceable fuses or high-fault protectors assembled as an integral unit in a supportive environment and enclosed housing of insulating material.

2.35 **FUSED MOLDED-CASE SWITCH** – A switch with integral replaceable fuses or high fault protectors assembled as an integral unit in a supportive and enclosed housing of insulating material.

2.36 **GROUND-FAULT DELAY** – An intentional time delay in the tripping function of a circuit breaker when a ground-fault occurs.

2.37 **GROUND-FAULT PICKUP SETTING** – The nominal value of the ground-fault current at which the ground-fault delay function is initiated.

2.38 **HEATING, AIR CONDITIONING, AND REFRIGERATION (HACR) CIRCUIT BREAKER** – One intended for use with multi-motor and combination loads such as are found in heating, air conditioning, and refrigeration equipment.

2.39 **HIGH-FAULT MODULE** – A self-contained unit, with or without provision for replaceable fuses or high-fault protectors, constructed for use with specific molded case products and with provision for connecting directly to the load terminals of the molded case product and that functions only to increase the short circuit interrupting rating of the combination.

2.40 **HIGH-FAULT PROTECTOR** – A replaceable fuse-like device intended for use with specific fused molded-case products and/or high-fault modules that function only to increase the short circuit interrupting rating of the molded-case product.

2.41 **INDEPENDENT TRIP CIRCUIT BREAKER** – A multipole circuit breaker constructed such that all poles are not intended to open when one or more poles open automatically.

2.42 **INSTANTANEOUS OVERRIDE** – A fixed current level at which an adjustable circuit breaker will override all settings and will trip instantaneously.

2.43 **INSTANTANEOUS PICKUP SETTING** – The nominal value of current that an adjustable circuit breaker is set to trip instantaneously.

2.44 **INSTANTANEOUS TRIP** – A qualifying term indicating that no delay is purposely introduced in the automatic tripping of the circuit breaker.

2.45 **INSTANTANEOUS TRIP CIRCUIT BREAKER (MOTOR CIRCUIT PROTECTOR OR CIRCUIT INTERRUPTER)** – Is one intended to provide short circuit protection only. Although acting instantaneously under short circuit conditions, these circuit breakers may include a transient dampening action to ride through initial motor transients.

2.46 **INTERCHANGEABLE TRIP UNIT** – One which can be interchanged by a user among circuit breaker frames of the same design. See also Rating Plug.

2.47 **INTERNAL MECHANISM** – The means by which the main contacts of a circuit breaker are actuated.

2.48 INTERRUPTING RATING – The highest RMS symmetrical current at rated voltage that a device is intended to interrupt under standard test conditions.

2.49 INVERSE TIME – A qualifying term indicating that there is a purposely introduced delayed tripping in which the delay decreases as the magnitude of the current increases.

2.50 I^2t (AMPERES SQUARED SECONDS) – An expression related to the circuit energy as a result of current flow. With respect to circuit breakers, the I^2t is expressed for the current flow between the initiation of the fault current and the clearing of the circuit.

2.51 LOCK-OFF DEVICE – A device that permits a molded-case product to be locked in the OFF position.

2.52 LOCK-ON DEVICE – A device that permits a molded-case product to be locked in the ON position.

2.53 LONG-TIME DELAY – An intentional time delay in the overload tripping of an adjustable circuit breaker's inverse time characteristics. The position of the long time portion of the trip curve is normally referenced in seconds at 600 percent of the current setting (I_r).

2.54 LONG-TIME PICKUP – The current at which the long-time delay function is initiated.

2.55 MECHANICAL INTERLOCK – A device or system that mechanically connects two or more circuit breakers or switches so that only selected ones can be closed at the same time.

2.56 MOLDED-CASE CIRCUIT BREAKER – A circuit breaker which is assembled as an integral unit in a supportive and enclosed housing of insulating material.

2.57 MOLDED-CASE SWITCH – A device designed to open and close a circuit by nonautomatic means, assembled as an integral unit in a supportive and enclosed housing of insulating material.

2.58 MULTIPOLE CIRCUIT BREAKER – A circuit breaker with two or more poles which provide two or more separate conducting paths.

2.59 NEUTRAL (or SOLID NEUTRAL) – An assembly consisting of an appropriate number of terminals providing for the connection of the neutral conductors. When used as a component of service equipment, the neutral also includes:

- a) A means for making the required bonding connection between the neutral and the enclosure; and
- b) A terminal for the grounding electrode conductor.

2.60 OPEN OPERATION – The movement of the contacts from the closed to the open position. The letter "O" signifies this operation.

2.61 OVERVOLTAGE-TRIP RELEASE DEVICE – A trip mechanism that causes a circuit breaker to open automatically if the voltage across the terminals of the trip coil rises above a predetermined value.

2.62 PEAK CURRENT – The maximum instantaneous current that flows in a circuit.

2.63 PILOT DUTY – The rating assigned to a relay or switch that controls the coil of another relay or switch.

2.64 POLE – That portion of a circuit breaker or switch associated exclusively with one electrically separated conducting path of its main circuit.

2.65 PROSPECTIVE CURRENT (AVAILABLE CURRENT) – The current that would flow in a circuit if a short circuit of negligible impedance were to occur at a given point.

2.66 RATED CONTROL VOLTAGE – The designated voltage that is to be applied to the closing or tripping devices to open or close a circuit breaker or switch.

2.67 RATED CURRENT (I_n) – The marked current rating and the maximum RMS current a circuit breaker can carry continuously without tripping and the maximum current the circuit breaker will carry without changing, deleting, or adding a part or parts such as trip units and rating plugs. See also current setting (I_r).

2.68 RATED FREQUENCY – The service frequency of the circuit for which the circuit breaker is designed and tested.

2.69 RATED VOLTAGE – The rated voltage is the nominal rms voltage for which the circuit breaker is designed to operate.

2.70 RATING – The designated limit or limits of the rated operating characteristic(s) of a device.

2.71 RATING PLUG – A self-contained portion of a circuit breaker that is interchangeable and replaceable in a circuit breaker trip unit by the user. It sets the Rated Current (I_n) of the circuit breaker.

2.72 RECOVERY VOLTAGE – The voltage that appears across the terminals of a pole of a circuit breaker upon interruption of the circuit.

2.73 REMOTELY OPERATED CIRCUIT BREAKER – A circuit breaker that contains an integral means to remotely open and close the circuit.

2.74 SERIES RATED (SERIES CONNECTED) – A group of overcurrent devices, connected in cascade, comprised of a circuit breaker or main fuse and one or more downstream circuit breakers that have been tested together to permit the branch or downstream circuit breakers to be applied on circuits where the available short circuit current exceeds the marked interrupting rating on the branch circuit breaker.

2.75 SHORT CIRCUIT CURRENT RATING – The maximum RMS prospective (available) current to which a device can be connected when protected by the specified overcurrent protective devices. The rating is expressed in amperes and volts.

2.76 SHORT-TIME DELAY – An intentional time delay in the tripping of a circuit breaker between the overload and the instantaneous pickup settings.

2.77 SHORT-TIME PICKUP – The current at which the short-time delay function is initiated.

2.78 SHUNT-TRIP RELEASE DATA – A release mechanism energized by a source of voltage which may be derived either from the main circuit or from an independent source.

2.79 SPECIAL PURPOSE NOT FOR GENERAL USE CIRCUIT BREAKER – A circuit breaker having special features limiting their suitability to specific applications.

2.80 SUPERVISORY CIRCUIT – A feature included in a circuit breaker and ground-fault circuit-interrupter that provides a manual method for testing the device by simulating a ground fault.

2.81 SWITCHING DUTY (SWD) CIRCUIT BREAKER – A circuit breaker intended to switch fluorescent lighting loads on a regular basis.

2.82 THERMAL MEMORY – The ability of an electronic trip unit to approximate heating due to cyclic overloads.

2.83 THERMAL MEMORY RETENTION – The ability to maintain thermal memory upon shutdown or power loss.

2.84 THRESHOLD CURRENT – The RMS symmetrical prospective current at the threshold of the current limiting range, where:

a) The peak current let-through in each phase is less than the peak of that symmetrical prospective current; and

b) The I^2t in each phase is less than the I^2t of a 1/2 cycle wave of the symmetrical prospective current.

2.85 TRIP-FREE CIRCUIT BREAKER – A circuit breaker designed so that the contacts cannot be held in the closed position by the operating means during trip command conditions.

2.86 TRIPPING – The opening of a circuit breaker by actuation of the release mechanism.

2.87 TRIP UNIT – A self-contained portion of a circuit breaker that is interchangeable and replaceable in a circuit breaker frame by the user. It actuates the circuit breaker release mechanism and it sets the Rated Current (I_n) of the circuit breaker unless a rating plug is used. See also Rating Plug.

2.88 UNDERVOLTAGE TRIP RELEASE – A release mechanism that causes a circuit breaker to open automatically if the control voltage falls below a predetermined value.

2.89 UNFUSED MOLDED-CASE SWITCH – See Molded-Case Switch.

3 Components

3.1 Except as indicated in 3.2, a component of a product covered by this Standard shall comply with the requirements for that component. See Annex A for a list of standards covering components generally used in the products covered by this Standard. A component shall comply with the ANCE, or the Canadian Standards Association, or the Underwriters Laboratories Inc. Standards as appropriate for the country where the product is to be used. When a product is intended for use in more than one country, a component shall comply with the appropriate component standards for all the countries in which it is intended to be used.

3.2 A component is not required to comply with a specific requirement that:

a) Involves a feature or characteristic not required in the application of the component in the product covered by this Standard; or

b) Is superseded by a requirement in this Standard.

3.3 A component shall be used in accordance with its rating established for the intended conditions of use.

3.4 Specific components are incomplete in construction features or restricted in performance capabilities. Such components are intended for use only under limited conditions, such as certain temperatures not exceeding specified limits, and shall be used only under those specific conditions.

4 Units of Measurement

4.1 The values given in SI (metric) units shall be normative, except for AWG/kcmil conductor sizes. Any other values are for information only.

5 Reference Publications

5.1 Where undated reference is made to ANCE, CSA or UL Standards, such reference shall be considered to refer to the latest edition and all amendments published to that edition up to the time when this Standard was approved. See Annex B.

5.2 A product shall comply with the installation codes and standards as appropriate for the country where the product is used. When the product is intended for use in more than one country, the product shall comply with the installation codes and standards for all the countries in which it is intended to be used.

MOLDED CASE CIRCUIT BREAKERS

CONSTRUCTION

6 All Types

6.1 General

6.1.1 A circuit breaker intended particularly for use in panelboards and the like shall be evaluated with respect to its intended application as well as under the requirements of this Standard.

6.1.2 A circuit breaker shall be provided with means for mounting.

6.1.3 A circuit breaker shall have an integral housing for all the mechanism and live parts except the operating handle and the wiring terminals, and shall be manually operable without opening this housing.

6.1.4 There shall be no direct opening in the front of a circuit breaker, except that a circuit breaker need not comply if a cotton indicator, as described in [26.7.11](#), does not ignite during the interrupting test described in Interrupting test, [26.7](#).

6.1.5 If a circuit breaker requires a specific receiving device, the combination of the circuit breaker and receiving device shall comply with all of the applicable requirements in this Standard.

6.1.6 A circuit breaker shall have the strength and rigidity necessary for its intended use and to meet the test requirements of this Standard.

6.1.7 A circuit breaker may be manufactured as a circuit breaker frame and an interchangeable trip unit and each shall be plainly marked in accordance with [47.1.2](#) and [60.1](#).

6.1.8 A Class CTL circuit breaker shall have a size or configuration that, in conjunction with the physical means provided in a Class CTL panelboard, prevents the installation of more circuit breaker poles than that number for which the assembly is designed and rated. See [47.4.2](#).

6.2 Corrosion protection

6.2.1 Iron and steel parts, except for thermal elements; magnet-pole faces; and hardened and polished parts such as latching surfaces and the like, where such protection is impractical, shall be protected against corrosion by enamelling, galvanizing, plating, or other equivalent means.

6.2.2 Phosphate treatment with an oil or wax coating is acceptable as corrosion protection for magnets and armatures; oil treatment is acceptable as corrosion protection for steel springs; and stainless steel is acceptable without additional protection if polished or treated when necessary.

6.2.3 Copper and brass are not acceptable for the plating of steel wire-binding screws, nuts, and stud terminals.

6.3 Cases – Insulating material

6.3.1 A case for mounting uninsulated live parts shall be strong, not easily ignited, moisture-resistant, and insulating. The case shall be of such material that it will withstand the most severe conditions likely to be met in service.

6.3.2 Ordinary fiber, rubber, and hot-molded shellac and tar compositions are not acceptable for the mounting of uninsulated live parts.

6.3.3 Insulating material, including barriers, shall have properties acceptable for the particular application.

6.3.4 An insulating barrier, which is required for the proper performance or installation of a circuit breaker, shall be an integral part of, or reliably attached to, the circuit breaker, or a marking shall be provided in accordance with [47.1.12](#).

6.3.5 Removable lug and terminal covers shall be permitted if specific marking on the circuit breaker housing is provided to indicate the need for replacement. See [47.1.13](#).

6.4 Current-CARRYING PARTS

6.4.1 General

6.4.1.1 Current-carrying parts shall be of silver, a silver alloy, copper, a copper alloy, or other metal acceptable for the application. The acceptability of metals shall be judged on the basis of their ability to carry current while the products in which they are used satisfy the performance requirements of this Standard. The acceptability of other metals to resist corrosion shall be in accordance with [6.2](#).

6.4.1.2 Screws, nuts, or wire binding screws made of iron or steel shall be permitted to be used to secure live parts, but shall not be depended upon to carry current.

6.4.1.3 Uninsulated live parts, other than soldering lugs or pressure wire-connectors meeting the requirements of [6.6.1.4](#) shall be so secured to the case or mounting surface that they will be prevented from turning. Friction between surfaces is not acceptable as a means of preventing the turning of live parts.

6.4.1.4 If parts are held together by screws, a threaded part shall have no fewer than two full, clean-cut threads engaged. If a screw does not extend all the way through a threaded part, the taper or lead and the first full thread are to be disregarded in a determination of the number of threads engaged.

6.4.2 Terminals

6.4.2.1 Except as described in 6.4.2.4, each field wiring terminal of a circuit breaker shall have a wire connector that has a capacity acceptable for the number, wire size, and type associated with the circuit breaker. See Table 6.1 and Terminations, Section 117. A wiring terminal shall be acceptable for the temperatures encountered. See also 6.4.2.9, 6.4.2.16, and 47.2.14.

Table 6.1
Terminal Current and Conductor Size

Terminal current in amperes ^a	Copper conductor			Aluminum or copper-clad aluminum conductor		
	Number of conductors	Size AWG or kcmil		Number of conductors	Size AWG or kcmil	
		60 °C	75 °C		60 °C	75 °C
15 or less	1	14	14	1	12	12
20	1	12	12	1	10	10
25	1	10	10	1	10	10
30	1	10	10	1	8	8
40	1	8	8	1	6	8
50	1	6	8	1	4	6
60	1	4	6	1	3	4
70	1	4	4	1	2	3
80	1	3	4	1	1	2
90	1	2	3	1		2
100	1	1	3	1		1
110	1		2	1		1/0
125	1		1	1		2/0
150	1		1/0	1		3/0
175	1		2/0	1		4/0
200	1		3/0	1		250
225	1		4/0	1		300
250	1		250	1		350
275	1		300	1		500
300	1		350	1		500
325	1		400	2		4/0
350	1		500	2		4/0
400	2		3/0	2		250
	1		500	1		750
450	2		4/0	2		300
500	2		250	2		350
550	2		300	2		500
600	2		350	2		500
700	2		500	3		350
800	3		300	3		400
1000	3		400	4		350

Table 6.1 Continued on Next Page

ULSE INC. COPYRIGHTED MATERIAL – NOT AUTHORIZED FOR FURTHER REPRODUCTION OR DISTRIBUTION WITHOUT PERMISSION FROM ULSE INC.

Table 6.1 Continued

Terminal current in amperes ^a	Copper conductor				Aluminum or copper-clad aluminum conductor					
	Number of conductors	Size AWG or kcmil		Number of conductors	Size AWG or kcmil					
		60 °C	75 °C		60 °C	75 °C				
				3		600				
1200	4		350	4		500				
	3		600							
1400	4		500	5		500				
1600	5		400	5		600				
	4		600							
2000	6		400	6		600				
	5		600							
2500	8		400	8		600				
	7		500	7		750				
	6		600	9		500				
3000	9		400	10		500				
	8		500	9		600				
	7		600	8		750				
4000	12		400	13		500				
	11		500	12		600				
	10		600	11		750				
5000 ^b	15		400	16		500				
	13		500	15		600				
	12		600	13		750				
6000 ^b	18		400	19		500				
	16		500	18		600				
	15		600	16		750				
^a For terminal current other than indicated, the next higher rating is to be used – for example, if rated 35 A, enter at 40 A. ^b Circuit breakers rated at more than 4000 A are to be considered as being bus- or cable-connected unless indicated otherwise in marking.										
mm ²	2.1	3.3	5.3	8.4	13.3	21.1	26.7	33.6	42.4	53.5
(AWG)	(14)	(12)	(10)	(8)	(6)	(4)	(3)	(2)	(1)	(1/0)
mm ²	67.4	85.0	107.2	127	152	177	203	253	304	380
(AWG or kcmil)	(2/0)	(3/0)	(4/0)	(250)	(300)	(350)	(400)	(500)	(600)	(750)

6.4.2.2 A wire connector provided with or specified for use with a circuit breaker shall comply with the appropriate requirements of UL, CSA, or Mexico specified in one of the following:

- a) Annex B, Ref. No. 6; or
- b) Annex B, Ref. No. 7. When these connectors are used, an interrupting test for the circuit breaker shall be performed if the interrupting rating of the circuit breaker is greater than 10 kA.

6.4.2.3 The tightening torque for a field wiring terminal shall be as specified by the circuit breaker manufacturer, and the circuit breaker shall be marked as required by 47.2.5. The specified tightening torque shall not be less than 90 percent and not more than 100 percent of the value used in the static heating test as specified in Annex B, Ref. No. 6 for the wire size corresponding to the ampere rating of the

circuit breaker. See Mechanical tests, [26.10.1](#). Torque values shall be permitted to be less than 90 percent if the connector is investigated in accordance with the lesser assigned torque value in Annex [B](#), Ref. No. 6.

6.4.2.4 Wire connectors or wire-binding terminals for the line or the load, or both, may be omitted if:

- a) Provision is made for a bus-bar connection;
- b) Provision is made for a plug-in connection;
- c) Field-installable kits are available from the manufacturer and the conditions in [6.4.2.5](#) are met; or
- d) The circuit breakers have a special form of construction, such as those providing a switching neutral pole or an isolated pole for water heater use, and the like; such devices shall be permitted to have means of connection considered acceptable for the intended purpose in place of a pressure terminal connector.

6.4.2.5 Field-installable connectors shall meet the following:

- a) Component terminal kits shall be available from the circuit breaker manufacturer, or one or more wire connectors shall be specified for field installation on the equipment;
- b) Fastening devices, such as studs, nuts, bolts, springs, and flat washers, or the like, as required for an effective installation, shall either be provided as part of the component terminal kit or mounted on, or separately packaged with, the circuit breaker;
- c) The installation of the terminal kit shall not involve the loosening or disassembly of parts other than those normally disassembled for installation and wiring;
- d) If the wire connector provided in a component terminal kit requires the use of a special tool for securing the conductor, any necessary instructions shall be included in the component terminal kit package or with the circuit breaker;
- e) Installation of the wire connectors in the intended manner shall result in a product that meets the requirements of this Standard; and
- f) The circuit breaker or circuit breaker frame, and component terminal kit shall be marked in accordance with [47.2.11](#).

6.4.2.6 A wire-binding screw may be used at a field wiring terminal intended for the connection of a 10 AWG (5.3 mm²) or smaller wire if upturned lugs or the equivalent are provided to retain the wire under the head of the screw should the screw become loosened.

6.4.2.7 A plug-in circuit breaker shall not have a screw or wire connector that can be used simultaneously for the connection of a conductor on the same side as the plug-in connection. A conversion kit with instructions may be provided to accomplish a change in the type of plug-in connection.

6.4.2.8 The plug-in connection members on a circuit breaker and on a receiving means shall have the strength necessary for the forces applied during inserting and removing the circuit breaker.

6.4.2.9 A plug-in circuit breaker shall be retained on the stabs without depending on the trim or cover of the enclosure.

6.4.2.10 If a screw-and-washer construction is used at a field wiring terminal, the screw shall not be smaller than No. 10 (4.8 mm) with no more than 32 threads per inch (per 25.4 mm).

6.4.2.11 A terminal plate tapped for a wire-binding screw shall be of metal not less than 1.27 mm (0.050 inch) thick and shall have not less than two full threads in the metal; except that a special alloy plate less than 1.27 mm (0.050 inch) but not less than 0.76 mm (0.030 inch) thick shall be permitted if the tapped threads have the necessary mechanical strength.

6.4.2.12 A terminal plate may have the metal extruded at the tapped hole so as to give the thickness necessary for at least two full threads provided that the thickness for the unextruded metal is not less than the pitch of the thread.

6.4.2.13 If conductors of the next larger size than that described in [Table 6.1](#) can be inserted into main terminals of a circuit breaker, the terminals shall be capable of securing such larger conductors, unless marked in accordance with [47.2.7](#).

6.4.2.14 Pressure terminal connectors capable of holding the next larger size wire as described in [6.4.2.13](#) additionally shall be capable of withstanding the secureness and pullout tests described in Annex B, Ref. No. 6 with the size conductors described in [6.4.2.13](#) and [Table 6.1](#).

6.4.2.15 A terminal for the connection of conductors other than those specified in [Table 6.1](#) shall be acceptable only if found appropriate for the particular application.

6.4.2.16 Using normally available tools such as screwdrivers, pliers or wrenches, it shall be possible to retighten the conductor securing means of a wire connector without removal of the connector from the terminal plate or bus or without removal of any conductor from the connector.

6.4.2.17 For an interchangeable trip circuit breaker frame rated 100 A or less, a single pressure terminal connector shall be made available by the circuit breaker manufacturer that properly accommodates all sizes of wire for which the frame is intended.

6.4.2.18 A dc circuit breaker intended to have poles connected in series shall have all connecting hardware, bus, and the like, either attached at the factory or provided as a kit. The kit shall comply with the requirements of [6.4.2.5](#). If other than normally available building wire is required, it shall be provided as part of the kit.

6.4.2.19 Jumpers requiring building wire to be bent with a radius less than the cold bend mandrel requirements of Annex B, Ref. No. 27, shall be provided with the circuit breaker or be made available as a kit.

6.4.3 Field wiring conductors

6.4.3.1 Conductors shall not differ by more than two wire sizes from the size referred to in [Table 6.1](#). The wire size shall not be smaller than 14 AWG (2.1 mm²).

6.4.3.2 Conductors shall consist of wire suitable for the particular application, when considered with respect to the temperature and voltage and conditions of service to which the wiring is likely to be subjected.

6.4.3.3 A conductor shall be constructed so as to withstand the stress of normal handling without damage to itself or to the unit. See [26.10.1.2](#).

6.4.3.4 Green coloring, with or without one or more yellow stripes, and white or gray coloring shall not be used for the covering of a conductor unless intended for connection to grounding and grounded circuit conductors, respectively.

6.4.3.5 The free length of a wiring conductor shall be at least 152 mm (6 inches).

6.4.3.6 Notwithstanding [6.4.3.5](#), the free length of a wiring conductor may be less than 152 mm (6 inches) when all of the following conditions are met:

- a) The device shall be manufactured with the conductor factory installed as intended for field installation in the specified end-use equipment;
- b) The conductor shall be of sufficient length for connection in the specified end-use equipment;
- c) The device shall be marked for use only in specific end-use equipment. This information may be provided with the installation instructions if the device is marked to reference the appropriate publication;
- d) Instructions for installation shall be provided with the device unless readily apparent; and
- e) The acceptability of the device shall be determined in the end-use equipment.

6.5 Operating mechanism

6.5.1 A multipole circuit breaker shall be constructed so that all poles will make and break simultaneously when operated manually or automatically in the intended manner; except that in a 2- or 3-pole circuit breaker rated at 125/250 V or less and having two operating poles intended for use on the outside (ungrounded) wires of a 3-wire, dc or single-phase ac system, the automatic tripping of either pole shall be permitted to be independent of the other if the independent tripping is indicated. See [47.4.6](#).

6.5.2 The handle of a circuit breaker shall not be capable of being readily left at or near the OFF position when the contacts are closed.

6.5.3 Single-pole circuit breakers rated at 120/240 V ac or 125/250 V dc shall have provision for the use of handle ties. Handle ties, when installed, shall:

- a) Operate both circuit breakers when either circuit breaker handle is manually operated;
- b) Not be readily removable; and
- c) Not obscure the ampere marking on either circuit breaker.

6.5.4 In Mexico and the United States, circuit breakers of ratings other than those mentioned in [6.5.3](#) may have provisions for handle ties. Handle ties, when installed, shall comply with [6.5.3](#), except the handle tie shall operate all circuit breakers when any handle is manually operated.

In Canada, this requirement does not apply.

6.5.5 Screws and nuts serving to attach operating parts to movable members shall be staked, upset, or otherwise locked in position to prevent loosening.

6.5.6 An operating handle of conducting material extending into the housing shall have provision for connection to an equipment grounding conductor. If the intended enclosure is of metal, this shall be permitted to be accomplished by having such operating handle of conducting material in electrical connection with the enclosure. The adequacy of such connection shall be determined by the electrical continuity test described in [37.1](#).

6.5.7 The means for operation of a circuit breaker shall be such that the contacts cannot be held in the closed position under overcurrent conditions – that is, the circuit breaker shall be trip-free from the

operating handle. The construction shall be such that when the operating handle is held in the ON position and the circuit breaker is tripped automatically, the contacts will not automatically return to the closed position.

6.5.8 A circuit breaker shall be permitted to have an adjustable instantaneous release. A circuit breaker of frame size 200 A or more and with a current rating (minimum of adjustment range where applicable) of 100 A or more or a circuit breaker rated more than 250 V shall be permitted to have an adjustable inverse time (overload) response. See the requirements for adjustable circuit breakers described in Section [12](#) and Section [32](#). Circuit breakers of other ratings shall not have an adjustable inverse time (overload) response.

6.5.9 Except as specified in [6.5.10](#), access to the trip mechanism of a circuit breaker or trip unit and tampering, changing, or interfering with the calibration of the trip mechanism or of a trip unit, except as noted in [6.5.8](#), shall require dismantling of the circuit breaker, or dismantling or removal of the trip unit, or the breaking of a seal.

6.5.10 A hole for a rod or wire shall be permitted in the housing of a circuit breaker or trip unit to permit tripping of the circuit breaker. Such holes shall not permit passage of a rod larger than 3.2 mm (1/8 inch) diameter. A button, lever, or similar member shall be permitted to be added for the same purpose. Any such hole or feature added shall not contribute to the interference with or change in calibration of the circuit breaker, permit blocking of the release mechanism, or permit contact with a live part involving a potential more than 42.4 V peak.

6.5.11 A circuit breaker rated at 100 A or less in conjunction with a voltage rating of not more than 240 V ac or 125/250 V dc shall be considered to comply with the interference aspect of [6.5.9](#) and [6.5.10](#), if interference with the automatic operation of the circuit breaker cannot be accomplished by:

- a) Insertion of a 0.8 mm (1/32 inch) diameter straight rod through any opening in the case above a plane 12.7 mm (1/2 inch) below the plane of the trim when the circuit breaker is mounted in the intended manner, and
- b) Insertion of a 2.8 mm (7/64 inch) diameter straight rod through any opening elsewhere in the case.

6.5.12 Any means for sealing shall be such that breaking or removing it will be plainly evident. Paper or cloth shall be permitted to be used as a seal indicator, but shall not be used as a means for holding parts together.

6.5.13 There shall not be any access, as defined in [6.5.14](#), to a part involving risk of electric shock within an area as indicated in [6.5.16](#):

- a) While changing a trip unit in an interchangeable trip unit circuit breaker,
- b) While replacing fuses or high-fault protectors in a fused circuit breaker, or
- c) While modifying the response of an adjustable circuit breaker.

6.5.14 With regard to access to live parts through openings in surfaces, a part is considered to be accessible if it can be contacted by a 51 mm (2 inch) long, 9.5 mm (3/8 inch) diameter rod having a hemispherical end, inserted through openings in the surface.

6.5.15 A risk of electric shock is considered to exist if the open circuit voltage between the part in question and earth ground or any other accessible part is more than 42.4 V peak, and the continuous current flow through a 500 ohm resistor connected between the points exceeds 5 mA rms.

6.5.16 The areas referred to in [6.5.13](#) are:

- a) The complete area of any opening created by the removal of interchangeable trip units,
- b) The complete area of any opening created by the removal of the limiters, and so forth, and
- c) Points within 51 mm (2 inches) of the periphery of any adjustment knob involved in modifying the response of a circuit breaker.

6.6 Spacings

6.6.1 General

6.6.1.1 The spacings of a circuit breaker shall not be less than those indicated in [Table 6.2](#). "Grounded Metal" includes circuit breaker mounting screws and fittings for the connection of a wiring system. A "Terminal" includes the terminal proper and associated metal having the same degree of exposure or accessibility. Spacings shall be measured between the bare portions of insulated conductors. The insulation shall be brought up to the wire connector when space for the wire insulation exists.

Table 6.2
Minimum Spacings in millimeters

Voltage between parts	At terminals				Other than at terminals					
	Between terminals of opposite polarity		Between terminals and any grounded metal ^a		Between uninsulated live parts of opposite polarity ^b		Between uninsulated live parts and any ground metal ^a			
	A		B		C		D ^c		E ^d	
	Through air	Over surface	Through air	Over surface	Through air	Over surface	Through air	Over surface	Through air	Over surface
0 – 130	12.7	19.1	12.7	12.7	6.4	9.5	12.7	12.7	6.4	9.5
131 – 300	19.1	31.8	12.7	12.7	6.4	9.5	12.7	12.7	6.4	9.5
301 – 1000 ^e	25.4	50.8	12.7	25.4	9.5	12.7	12.7	25.4	9.5	12.7

NOTES:

- 1 An isolated dead metal part (such as a screw head or a washer) interposed between uninsulated live parts of opposite polarity or between an uninsulated live part and a grounded dead metal part is considered to reduce the spacing by an amount equal to the dimension of the interposed part along the path of measurement.
- 2 In measuring an over surface spacing, any slot, groove, or the like, 0.33 mm (0.013 inch) wide or less in the contour of insulating material shall be disregarded.
- 3 In measuring spacings, an air spacing of 0.33 mm (0.013 inch) or less between a live part and an insulating surface shall be disregarded, and the live part considered in contact with the insulating material.

^a The spacing to the enclosure or mounting means shall be permitted to be reduced if an acceptable liner of insulating material, not less than 0.8 mm (1/32 inch) thick, is used to provide the required spacing through air.

^b Not applicable for spacings between parts of opposite polarity on a control circuit printed wiring board with conformal coating. See [Table 6.3](#) and Printed Circuit and Wiring Board Assembly, [6.6.2](#).

^c If indentation or deformation of the overall enclosure or circuit breaker mounting means could reduce spacings to less than those indicated in Column E.

^d If indentation or deformation of the overall enclosure or circuit breaker mounting means would not affect spacings.

^e Or 1500 Vdc.

mm	0.8	6.4	9.5	12.7	19.1	25.4	31.8	50.8
(inches)	(1/32)	(1/4)	(3/8)	(1/2)	(3/4)	(1)	(1-1/4)	(2)

6.6.1.2 The external spacing through air and over surface shall not be less than 3.2 mm (1/8 inch) between uninsulated line and load live parts of the same polarity.

6.6.1.3 Except as indicated in [6.6.1.4](#), a pressure terminal connector shall be provided with a positive restraint, such as a shoulder or boss, to restrict turning that would reduce spacings to values less than those required. A lock washer alone is not acceptable for this purpose.

6.6.1.4 Means to prevent turning as indicated in [6.6.1.3](#) need not be provided if spacings are not less than the minimum acceptable values:

- a) When the connector and any connector of opposite polarity have each been turned 30° toward the other, and
- b) When the connector has been turned 30° toward other opposite polarity live parts or toward grounded dead metal parts.

6.6.1.5 The spacings of a circuit breaker shall be measured with the circuit breaker wired with conductors of the size shown in [Table 6.1](#), as appropriate for temperature rating(s) of the wires (see [47.2.9](#)). Type TW wire is to be used for sizes 8 AWG (8.4 mm²) and smaller; Type THW, TW75 or TW for sizes larger than 8 AWG (8.4 mm²). Solid conductors are to be used for wire sizes 10 AWG (5.3 mm²) and smaller. For circuit breakers acceptable for use with both copper and aluminum conductors, both types of wire of the proper size for the ampere rating are to be evaluated.

6.6.1.6 Except as noted in [6.6.1.7](#) and [6.6.1.11](#), an insulating barrier or liner used as the sole separation between uninsulated live parts and grounded dead metal parts (including the enclosure) or between uninsulated live parts of opposite polarity, shall be of a material which is acceptable for the mounting of uninsulated live parts and not less than 0.71 mm (0.028 inch) thick.

6.6.1.7 Fiber not less than 0.71 mm (0.028 inch) thick shall be permitted to be used as the sole separation between the enclosure and an uninsulated metal part electrically connected to a grounded circuit conductor.

6.6.1.8 A barrier or liner used in conjunction with an air space shall not be less than 0.71 mm (0.028 inch) thick except as noted in [6.6.1.10](#) and [6.6.1.11](#).

6.6.1.9 If the barrier indicated in [6.6.1.8](#) is of fiber, the air space shall not be less than 0.8 mm (1/32 inch).

6.6.1.10 A barrier or liner used in conjunction with an air space of one-half or more of the required through-air spacing shall be permitted to have a thickness of not less than 0.33 mm (0.013 inch), see also [6.6.1.12](#), if it is:

- a) Of material acceptable for supporting uninsulated live parts;
- b) Of adequate strength if exposed or otherwise likely to be subjected to damage;
- c) Securely held in place; and
- d) Located so that it shall not be adversely affected by operation of the equipment in service.

6.6.1.11 Insulating material having a thickness less than that indicated in [6.6.1.6](#), [6.6.1.8](#) and [6.6.1.10](#) shall be permitted to be used if tested and found acceptable as indicated in [26.10.2](#) and the mechanical strength and flammability is acceptable for the particular application.

6.6.1.12 Clamped joints between insulating-material members shall provide tightly-mated surfaces. Spacings shall be measured through cracks unless a clamped joint has passed the test specified in

Section 43. A clamped joint is a joint between two pieces of insulation that are under pressure as shown in Figure 6.1. Adhesives, cements, or the like, if used to effect a seal in place of a tightly-mated joint, shall comply with Annex B, Ref. No. 12 The requirement for the test in Section 43 is only applicable for those areas where spacings are covered by Table 6.2. The acceptability of other spacings such as internal breaker spacings is demonstrated by successfully passing the test program.

Figure 6.1
Clamped Joint

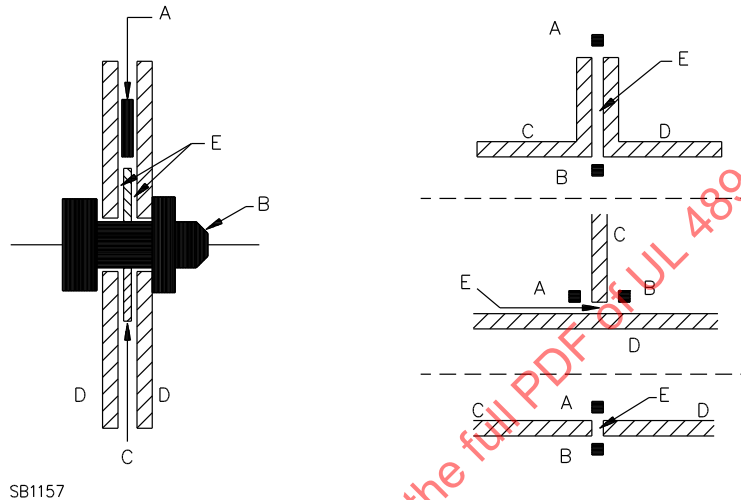

SB1157

Parts A, B – Live parts of opposite polarity, or a live part and a grounded metal part with spacing through the crack between C and D less than required in Table 6.2.

Parts C, D – Insulating barriers clamped tightly together so that the dielectric strength between A and B is greater than the equivalent air spacing.

Part E – The clamped joint.

6.6.1.13 The spacing between uninsulated live parts of different circuits (such as between shunt trip release and primary circuits) shall not be less than that required for the circuit of the higher voltage.

6.6.1.14 Live screw-heads or nuts on the underside of a case intended for surface mounting shall be suitably insulated or isolated from the enclosure or from a grounded metal mounting-plate in one of the following ways:

- a) Spaced according to Table 6.2 and reliably prevented from turning or loosening by staking, upsetting, or other equivalent means;
- b) Countersunk not less than 3.2 mm (0.125 inch) below the surface of the case; prevented, as in Item (a) above, from turning or loosening; and having under the case a barrier of moisture-absorption-resistant, insulating material fastened to the enclosure or to the metal mounting-plate; the barrier shall have such an area that Table 6.2 spacing will be maintained; or
- c) Countersunk not less than 3.2 mm (0.125 inch) in the clear, and then covered with a waterproof, insulating, sealing compound which will not soften at a temperature 15 °C (27 °F) higher than the temperature attained in the circuit breaker at the point where it is used, but not lower than 90 °C (194 °F) in any case. Determination of the softening point of a sealing compound shall be made in accordance with applicable requirements in Annex B, Ref. No. 8.

6.6.2 Printed circuit and wiring board assembly

6.6.2.1 The spacings on a printed wiring board assembly shall be permitted to be less than indicated in [Table 6.2](#) if a conformal coating and spacings are utilized in compliance with the requirements described in [Table 6.3](#). The coated printed wiring assembly shall comply with the requirements for conformal coatings described in [26.10.3](#). A coating shall not be required if the voltage is 50 V or less and the board is located so that it is not readily subject to contamination by dust.

Table 6.3
Minimum Opposite Polarity Spacings on Printed-Wiring Assemblies with Conformal Coatings

Voltage between parts	Power available	Minimum spacings	
		mm	(Inch)
0 – 600	Unlimited	0.8	(1/32)
601 – 1000	Unlimited	1.6	(1/16)
1001 – 1500 ^b	Unlimited	2.4	(1/8)
0 – 30	Limited ^a	0.4	(1/64)

NOTE: Minimum spacing between live parts of opposite polarity. Spacing between live parts and dead metal shall comply with [Table 6.2](#).

^a See [6.6.3.1](#) and [6.6.3.6](#).

^b Volts dc.

6.6.2.2 As an alternative to the measurement method specified in [6.6.2.1](#), the minimum acceptable clearances (through air spacings) and creepage distances (over surface spacings) for a printed wiring board assembly may be evaluated as specified in [6.6.2.3](#) – [6.6.2.5](#) using the applicable requirements in Annex [B](#), Ref. No. 9.

6.6.2.3 When applying the requirements in Annex [B](#), Ref. No. 9, the environment for a printed wiring board assembly within a circuit breaker is considered to be:

- a) Pollution degree 3 for an assembly without a conformal coating;
- b) Pollution degree 2 for an assembly with a conformal coating; or
- c) Pollution degree 1 for an assembly with a conformal coating complying with the requirements in Annex [B](#), Ref. No. 9.

6.6.2.4 For Clearance B (controlled overvoltage) requirements in Annex [B](#), Ref. No. 9, the applicable overvoltage category for line-voltage circuits is Category III. Category I is applicable to low-voltage circuits if short circuit between the parts involved may result in operation of the controlled equipment that increases the risk of fire or electric shock. Any overvoltage protection device needed to achieve these categories shall be provided as an integral part of the circuit breaker.

6.6.2.5 Where measurement of clearances and creepage distances is involved to establish the minimum spacings, the methods specified in Measurement of Clearance and Creepage Distances, in Annex [B](#), Ref. No. 9, shall be used.

6.6.3 Class 2 circuits

6.6.3.1 Minimum electrical spacings for Class 2 circuits that comply with [Table 6.5](#) shall be as described in [6.6.3.2](#) – [6.6.3.5](#).

6.6.3.2 Minimum electrical spacings between multiple Class 2 circuits shall be as shown in [Table 6.4](#).

6.6.3.3 Minimum electrical spacings between parts of a power circuit and parts of a Class 2 circuit at locations other than terminals shall be as shown in [Table 6.5](#).

6.6.3.4 Minimum electrical spacings between terminals of a power circuit and terminals of a Class 2 circuit shall be as shown in Column B of [Table 6.2](#).

6.6.3.5 In order to comply with the spacings in [Table 6.4](#) and [Table 6.5](#):

- a) Uninsulated live parts shall be secured against movement.
- b) Insulated conductors shall be protected from contact with live parts or secured to meet the spacing required.
- c) If a barrier is used as allowed in [Table 6.5](#), it shall not be less than 0.71 mm (0.028 inch) thick except that it shall be permitted to have a thickness of not less than 0.33 mm (0.013 inch), if the material is:
 - 1) Of material acceptable for supporting uninsulated live parts,
 - 2) Of adequate strength if likely to be subjected to damage;
 - 3) Securely held in place; and
 - 4) Located so that it shall not be adversely affected by operation of the equipment in service.

Table 6.4
Class 2 Circuit Spacings

Minimum spacings, mm (inch)		
Through air and over surface		Between 2 or more Class 2 insulated conductors – insulation on all conductors rated for maximum voltage
At terminals	At other than terminals	
3.2 (1/8)	1.6 (1/16)	No minimum requirement

Table 6.5
Power Circuit – Class 2 Circuit Spacings

Spacings between power circuits and Class 2 circuits at other than terminals		
Minimum spacings, mm (inch)		2 or more insulated conductors with insulation on each conductor rated for the conductor circuit voltage
No insulation	Separating barrier or one insulated conductor with insulation rated for maximum voltage	
6.4 (1/4)	1.6 (1/16)	No minimum requirement

6.6.3.6 A low-voltage, limited energy Class 2 circuit is a circuit supplied from an isolated secondary winding of a transformer where the open circuit secondary voltage does not exceed 30 V rms or 42.4 V peak. The transformer shall comply with one of the following:

- a) The transformer complies with the construction and test requirements in Annex B, Ref. No. 10;

b) The transformer has an inherent winding impedance which will limit the secondary short circuit current to 8 A at one minute; or

c) The VA output capacity of the secondary winding is 250 VA or less, and an overcurrent protective device is connected in the secondary circuit rated at: 5 A or less for voltages up to and including 20 V rms; or 100/V_{max} for voltages over 20 V rms, up to and including 30 V rms. V_{max} is the maximum output voltage regardless of load with rated input applied.

6.6.3.7 With regard to the requirement in [6.6.3.6](#), a fixed series impedance in the secondary circuit shall be permitted to be used to limit the output of the transformer and, in such case, the secondary winding of the transformer and the fixed series impedance shall be investigated as part of the line-voltage circuit. The maximum output capacity of the secondary circuit shall be determined as described in the power level determination test of [26.10.4](#).

6.6.3.8 An overcurrent-protective device as indicated in [6.6.3.6](#)(c) shall:

a) Not be of an automatically reset type;

b) Be trip-free from the reclosing mechanism if of the manually reset type; and

c) Not be interchangeable with one of a larger current rating if it is a renewable device.

7 Current-Limiting Circuit Breakers

7.1 Current-limiting circuit breakers shall comply with the construction requirements in All Types, Section [6](#).

8 Instantaneous-Trip Circuit Breakers

8.1 This section covers additional requirements for instantaneous-trip circuit breakers.

8.2 An instantaneous-trip circuit breaker shall have an adjustable instantaneous release.

8.3 An adjustable setting means of an instantaneous-trip circuit breaker that is accessible without opening a door or removing a cover shall be constructed so that a stop to limit the maximum setting may be installed.

9 Circuit Breaker and Ground-Fault Circuit-Interrupters

9.1 General

9.1.1 This section covers additional requirements for circuit breakers and ground-fault circuit-interrupters that provide overcurrent protection and personnel protection against risk of electric shock as required by the National Installation Codes in Annex [B](#), Ref. No. 1. These devices are rated Class A, single-pole, 120 V ac and/or 127 V ac, 60 Hz, 2-pole, 120/240 V ac, 60 Hz, and 3-pole, 208Y/120 V ac and/or 220Y/127 V ac, 60 Hz.

9.1.2 The ground-fault circuit-interrupter portion shall comply with the construction requirements in Annex [B](#), Ref. No. 11 and Section [9](#) of this Standard, except that printed wiring board spacings may be evaluated in accordance with [6.6.2.2](#) – [6.6.2.5](#).

9.2 Supervisory circuit

9.2.1 If a 2-pole, 120/240 V ac, or 3-pole, 208Y/120 V ac and/or 220Y/127 V ac circuit breaker mechanism is a common-trip type, the supervisory circuit need only be provided from one ungrounded pole. If a 2-pole or 3-pole circuit breaker mechanism is not a common-trip type, the need for more than one supervisory circuit shall be evaluated.

10 Circuit Breakers with Equipment Ground-Fault Protection

10.1 This section covers additional requirements for circuit breakers with equipment ground-fault protection that provide overcurrent protection and ground-fault protection of equipment.

10.2 A multipole device that receives operating power from the circuit to which it is connected shall provide ground-fault protection with one or more ungrounded line terminals of the circuit breaker energized.

11 Integrally Fused Circuit Breakers, High-Fault Protectors, and High-Fault Modules

11.1 This section covers additional requirements for fused circuit breakers, high-fault protectors, and fused high-fault modules. High-fault modules without provisions for fuses or high-fault protectors need only comply with the construction requirements of Section 6 and 11.4 – 11.7.

11.2 An integrally fused circuit breaker shall automatically trip when the cover over the high-fault protectors or fuses, or their container, if separate, is removed if the cover can be removed with the circuit breaker ON.

11.3 An integrally fused circuit breaker shall automatically trip by signal, other than main current let-through, from fuses or high-fault protectors upon the clearing of one or more fuses or protectors, unless the circuit breaker is marked in accordance with 52.4.

11.4 Spacings at the load terminals of a high-fault protector shall comply with Table 6.2, Columns A and B.

11.5 Spacings at other than the load terminals of a high-fault module shall comply with Table 6.2, Columns C, D, and E.

11.6 If two or more high-fault protectors or high-fault modules having different let-through characteristics are provided for different ranges of ratings within a frame size, the construction shall be investigated in accordance with 31.4, unless a rejection means is provided to prevent the installation of a protector in any lower rated circuit breaker where it is not intended.

11.7 If two or more high-fault protectors or high-fault modules are provided for different ranges of ratings within a frame size, the combination shall be investigated in accordance with 31.4, unless a rejection means is provided to prevent the installation of a protector to any lower rated circuit breaker where it is not intended.

11.8 Except as indicated in 11.9, a high-fault protector or high-fault module casing shall be of ceramic, melamine impregnated glass fiber, or the equivalent.

11.9 Materials other than those specified in 11.8 shall be permitted if they are determined to be acceptable for the application.

11.10 Among the factors taken into consideration during an investigation, as indicated in [11.9](#), are the following properties of a material:

- a) Physical strength;
- b) Resistance to impact;
- c) Moisture-absorptive properties;
- d) Combustibility; and
- e) Resistance to distortion at temperatures to which the casing may be subjected under conditions of normal or abnormal use.

All of these factors shall be considered with regard to thermal aging.

11.11 Connections between the link and the terminals of a high-fault protector shall be such that a permanent electrical connection is provided. The connection shall be soldered, brazed, or welded, or shall otherwise be made permanently and adequately secure.

11.12 An adhesive used in a high-fault protector or high-fault module shall adequately and reliably secure together the parts that it is intended to secure.

11.13 To determine whether the adhesive complies with the requirement in [11.12](#), samples of the high-fault protector or high-fault module shall be subjected to appropriate interrupting tests, in combination with the circuit breaker after conditioning. Conditioning tests on the adhesive shall not be required if the device performs acceptably during the interrupting tests with the adhesive omitted.

12 Adjustable Circuit Breakers

12.1 This section covers additional requirements for adjustable circuit breakers.

12.2 As concerns the current setting, these circuit breakers are classed as either Type A or Type B. See [12.3](#) and [12.4](#).

12.3 The current setting (I_r) of a Type A circuit breaker shall not be adjustable to a value greater than the rated current (I_n) of the circuit breaker.

12.4 A Type B circuit breaker shall be restricted so that the current setting (I_r), once fixed at a particular value, cannot be changed to one higher, except by the addition or substitution of a part requiring use of a tool.

12.5 For a Type A circuit breaker, the current setting (I_r) shall be that which can be inferred from the device's settings, markings, or instruction literature. For a Type B circuit breaker, the current setting shall be that of the marking.

12.6 Circuit breakers may be provided with an energy-reducing maintenance setting that reduces the overall trip time over a predetermined current level.

12.7 The energy-reducing maintenance setting referenced in [12.6](#) may be enabled by means of a control on the circuit breaker or by means of an external control connection to the circuit breaker.

12.8 A circuit breaker that includes an energy-reducing maintenance setting shall be provided with an indicator on the circuit breaker, such as an LED, indicating lamp or electronic status display, to indicate that the setting is enabled.

13 Heating, Air Conditioning, and Refrigeration (HACR) Circuit Breakers

13.1 Heating, air conditioning, and refrigeration (HACR) circuit breakers shall comply with the construction requirements in All Types, Section [6](#).

14 Remotely-Operated Circuit Breakers

14.1 This section covers additional requirements for remotely-operated circuit breakers.

14.2 A remotely-operated circuit breaker shall be trip free and the operating handle and mechanism shall be independent of the remotely-controlled operation.

14.3 In a 2-pole remotely-operated circuit breaker, the remotely controlled operation shall be permitted to operate only one pole.

15 Switching Duty (SWD) Rated Circuit Breakers

15.1 Switching duty (SWD) rated circuit breakers shall comply with the construction requirements in All Types, Section [6](#).

16 400 Hz Rated Circuit Breakers

16.1 Circuit breakers rated 400 Hz shall comply with the construction requirements in All Types, Section [6](#).

17 Draw-Out Circuit Breakers

17.1 This section covers additional requirements for draw-out circuit breakers.

17.2 The configuration of the grounding means between a metal part of a draw-out type circuit breaker intended to be grounded and any permanently grounded part shall be such that grounding continuity is established 3.2 mm (1/8 inch) before either primary or secondary disconnects of the draw-out unit are energized; and also be maintained until both primary and secondary disconnects have been de-energized by at least 3.2 mm (1/8 inch). See the electrical continuity test described in [37.1](#).

17.3 Draw-out circuit breakers shall be equipped with self-coupling disconnecting devices.

17.4 Interlocks shall be provided:

- a) To prevent moving the circuit breaker to or from the connected position when the circuit breaker is in the closed position; and
- b) To prevent closing the circuit breaker unless the primary disconnecting devices are in full contact or are separated by a distance that will withstand a minimum voltage described in [37.2](#).

17.5 Secondary disconnects and interlock switches shall be designed and rated for their applications and shall comply with the requirements of Annex [B](#), Ref. No. 28.

18 Series-Connected Circuit Breakers

18.1 Series-connected circuit breakers shall comply with the construction requirements in All Types, Section [6](#).

19 Interchangeable-Trip Circuit Breakers

19.1 This section covers additional requirements for interchangeable-trip circuit breakers.

19.2 A circuit breaker having a frame size of 100 A or less in conjunction with a voltage rating of not more than 240 V ac or 125/250 V dc, shall not have an interchangeable trip unit.

19.3 A circuit breaker having a frame size of more than 100 A in conjunction with a voltage rating of not more than 240 V ac or 125/250 V dc, and any circuit breaker having a voltage rating greater than 240 V ac or 125/250 V dc, shall be permitted to have interchangeable trip units; except that an interchangeable trip unit for use in a circuit breaker having a voltage rating of not more than 240 V ac or 125/250 V dc shall not have a rating of less than 50 A. In any case, an interchangeable trip unit rated at 50 A or less shall be clearly marked in accordance with [60.5](#).

19.4 An interchangeable trip unit shall not be capable of setting the current rating higher than the rating of the frame.

19.5 An interchangeable trip unit shall not be adjustable beyond the limitations imposed by [6.5.8](#) without breaking a seal or a permanent fastening.

19.6 An interchangeable trip unit circuit breaker shall not have any parts that will fall out of the circuit breaker housing when its cover is removed with the circuit breaker mounted in any position on a vertical surface.

19.7 An interchangeable-trip circuit breaker that employs a rating plug shall either be nonfunctional (circuit open) or function at its lowest ampere rating when its rating plug is not in place.

20 High-Intensity-Discharge (HID) Type Circuit Breakers

20.1 High-intensity-discharge (HID) type circuit breakers shall comply with the construction requirements in All Types, Section [6](#).

21 Circuit Breakers for Use with 16 or 18 AWG Wire

21.1 Circuit breakers for use with 16 or 18 AWG wire shall comply with the construction requirements in All Types, Section [6](#).

22 4-Pole Circuit Breakers

22.1 4-pole constructions shall be permitted to be used for 3-phase circuits where a switched neutral is required. The fourth pole shall be provided with overcurrent protection of any value between 0 through 100 percent of the other poles, inclusive. See [26.1.18](#), [42.1 – 42.3](#), and [64.1](#).

23 Circuit Breakers and Surge Protective Devices

23.1 Circuit breakers and surge protective devices shall comply with the construction requirements in All Types, Section [6](#).

24 Special Purpose Not for General Use Circuit Breakers

24.1 Special purpose not for general use circuit breakers shall comply with the construction requirements in All Types, Section 6, except the type or construction of the terminals are such the circuit breaker can only be used in specific equipment applications and is not suitable for general installation in accordance with Annex B, Ref. No. 1.

25 Circuit Breakers with Electronic Trip Units

25.1 Circuit breakers with an electronic trip unit shall be provided with thermal memory and comply with the requirements in 26.2.6. The thermal memory may be defeated or turned off for manufacturing and validation purposes.

TESTS

26 Standard Circuit Breakers

26.1 General

26.1.1 The performance of a circuit breaker construction shall be investigated by subjecting representative sets to the test program indicated in Table 26.2. At the option of the manufacturer, Test Sequences X, Y, and Z may be combined for all frame sizes. When combining X-Y-Z Sequences or Y-Z Sequences, the Interrupting Test in the Y Sequence may be omitted.

26.1.2 Samples shall be selected based on Table 26.1.

Table 26.1
Sets of Samples

Ampere rating of frame	Interchangeable trip unit	Samples per set ^a	
		Test sequence ^b	
		X or X-Y-Z	Y or Z or Y-Z
0 – 225	No	3 or 4 ^c	3 or 4 ^c
0 – 225	Yes	3 frames, 3 trip units	3 frames, 3 trip units
226 – 400	No	3 ^d	2
226 – 400	Yes	2 frames, 3 trip units	2 frames, 2 trip units
401 – 1600	No	3 ^e	1
401 – 1600	Yes	1 frame, 3 trip units	1 frame, 1 trip unit
1601 and higher	No	1	1
1601 and higher	Yes	1 frame, 1 trip unit	1 frame, 1 trip unit

^a If a circuit breaker is not marked "line" and "load", one sample shall be tested with reversed line and load connections or an additional sample of each test set shall be provided. When only one sample constitutes a test set for operating tests, a second sample is required for reversed line-load connection tests. For reversed line-load connections, see 26.1.25.

^b One set per test sequence or combination of test sequences.

^c See 26.1.5 and 26.1.19.

^d See 26.1.7 and 26.2.1.2.

^e See 26.1.7 and 26.2.1.3.

**Table 26.2
Test Sequences**

Circuit-breaker type		Fully magnetic and solid-state trip ^a and non-ambient compensated breakers ^b rated 25 °C or 40 °C ^{c,d}	Ambient compensated breakers				
Test	Clause	Sequence			Sequence		
		X	Y	Z	X	Y	Z
1. 200 percent calibration at 25 °C (77 °F)	26.2.2	X	X	X	X	X	X
2. 135 percent calibration at 25 °C (77 °F)	26.2.3	X			X	X	
3. 200 percent calibration at 40 °C (104 °F)	26.2.2				X		
4. 135 percent calibration at 40 °C (104 °F)	26.2.3				X		
5. Calibration of adjustable instantaneous trip	26.2.5		X			X	
6. Overload	26.3	X			X		
7. 100 percent calibration at 40 °C (104 °F) ^{e,f,g}	26.2.4 , 26.4	X			X		
8. Temperature and 100 percent calibration at 25 °C (77 °F)	26.2.4 , 26.4	X			X		
9. Endurance	26.5		X			X	
10. 200 percent calibration at 25 °C (77 °F)	26.6		X			X	
11. 135 percent calibration at 25 °C (77 °F) ^k	26.6		X			X	
12. 135 percent calibration at 40 °C (104 °F) ^h	26.6					X	
13. Interrupting	26.7		X ⁱ	X ^j		X ⁱ	X ^j
14. 200 percent trip-out at 25 °C (77 °F)	26.8		X	X		X	X
15. Dielectric voltage-withstand	26.9	X	X	X	X	X	X

X – indicates test required.

NOTE: For circuit breakers rated ac/dc, see [26.1.8](#) – [26.1.13](#).

^a Circuit breakers whose automatic operation does not depend on the heating effect of current.

^b Circuit breakers whose automatic operation depends on the heating effect of current and are affected by changes in ambient temperature.

^c If a circuit breaker operates such that it will not carry rated current at 40 °C (104 °F), it may, at the option of the manufacturer, be tested and rated as a 25 °C (77 °F) circuit breaker.

^d If a circuit breaker includes any thermal compensation in its tripping mechanism, and if the manufacturer desires to have the circuit breaker marked "40 °C", it shall be subjected to the tests for an ambient compensated breaker.

^e This test may be performed after the temperature and 100 percent calibration tests at 25 °C (77 °F).

^f Applies only to circuit breakers rated 40 °C (104 °F).

^g For a non-ambient compensated circuit breaker rated 40 °C (104 °F), the test may be combined with the temperature test if the ambient temperature is 40 °C during the temperature test.

^h May be omitted if the tripping time at 135 percent of rated current in a 25 °C (77 °F) ambient after the endurance test is no more than it was before the endurance test.

ⁱ Test current shall be in accordance with [Table 26.13](#) and operations shall be O-t-CO, where t is minimum of 2 minutes, maximum of 1 hour.

^j Test current shall be in accordance with [Table 26.12](#) and operations shall be in accordance with [Table 26.10](#).

^k May be omitted for solid-state trip breakers having a frame size of 226 A or greater.

26.1.3 No conditioning of the circuit breaker shall take place during or between tests. During the test program, a circuit breaker shall be mounted with the front of the circuit breaker on a vertical plane in a position which would normally cause the line terminals to be at the top; except that for the 135- and 200-percent calibration test and dielectric voltage-withstand test, a circuit breaker may be mounted in any position in which it can be properly used.

26.1.4 If after any overcurrent operation where the automatic operation of the circuit breaker occurs but the contacts do not initially reclose, the following procedure is acceptable to establish continuity of the test sample:

- a) The circuit breaker may be operated up to 10 cycles of operation to establish continuity. Once continuity is established on all poles, no other manual operations shall be conducted other than that required to complete the test sequence.
- b) The first cycle of operation is counted from when the breaker mechanism can be reset to the "off" position. Each operation to the "on" and "off" position shall constitute one cycle.
- c) The manual operation of the mechanism may be applied to the handle or other operating mechanism used during the test such as a motor operator, or other exterior handle operator.

No other physical movement, contact, or other conditioning of the breaker shall be permitted, other than that required to complete the test sequence.

26.1.5 The evaluation of a circuit breaker of a frame size of 225 A or less of a specific pole construction shall include the testing of sets of samples of the maximum and minimum ratings. Sets of samples of one or more intermediate ratings may be additionally required to be subjected to the complete test program or a partial test program depending on construction differences.

26.1.6 For circuit breaker ratings with ratings of 15 A and below, the full evaluation shall include the 15 A rating representing the minimum rating. Where the construction of the 15 A and the lower ratings are identical except for the bimetal, the evaluation of the lowest rating shall be limited to the Z sequence, and the high available fault current test if applicable. Where the constructions are not identical, the largest ampere rating of each construction break shall also be evaluated to the Z sequence and the high available fault current test.

26.1.7 The investigation of a circuit breaker of frame size more than 225 A usually requires complete testing of sets of the maximum rating only, unless basic construction differences are present. A set of the minimum rating shall be subjected to 200, 135, and 100 percent calibration and, where applicable to the instantaneous trip calibration, whenever such tests are not required on this rating as part of a more extensive test program. If the frame size includes ampere ratings of 125 A or less, but more than 30 A, that are to be marked for use with 75 °C (167 °F) wire, ratings shall be selected for the overload and temperature tests based on the use of 75 °C (167 °F) wire. In selecting the rating(s) for test, consideration shall be given to the relative heat dissipating effect of the 60 °C (140 °F) versus 75 °C (167 °F) wire size for the particular ampere rating.

26.1.8 If the marked rating of a circuit breaker includes both alternating and direct current, or if the marked rating does not exclude one or the other, the acceptability of the circuit breaker for both ratings shall be determined. The ac rating shall be verified by the test program described in [Table 26.2](#). To verify the dc rating, it will ordinarily be necessary only to additionally subject a previously untested sample set that has the maximum ampere rating of the frame size, to:

- a) All calibration and trip-out tests with either ac or dc, whichever is more convenient;
- b) Overload, endurance, and interrupting tests with dc; and
- c) Dielectric voltage withstand tests with ac.

26.1.9 Each pole of a multipole dc circuit breaker shall be tested individually unless marked in accordance with [47.4.8](#) and investigated in accordance with [26.1.10](#) – [26.1.13](#).

26.1.10 A multipole dc circuit breaker intended to have poles wired in series shall be wired in accordance with the manufacturer's instructions. If specific hardware or parts are required, they shall either be available as a kit or be shipped with the circuit breaker and comply with [71.2](#).

26.1.11 Notwithstanding [26.1.25](#), for a dc circuit breaker that is required to be wired in series such that the same number of poles (contacts) are exposed to the current in both directions simultaneously, testing in both the forward and reverse direction is not required.

26.1.12 Multipole dc circuit breakers marked for more than one wiring configuration shall be subjected to a sufficient number of tests to represent all configurations. Examples:

- a) For interrupting tests, a configuration with the least number of poles energized shall represent configurations with more poles energized.
- b) For temperature tests, a configuration with the most number of poles energized shall represent configurations with a fewer number of poles energized.
- c) Calibration tests shall be conducted on the configurations with both the most and least number of poles energized.

26.1.13 For the endurance, overload, and interrupting tests, a dc circuit breaker intended for use on a system having one conductor grounded shall be tested with the enclosure or mounting surface connected to the negative conductor through a fuse as described in [26.1.27](#).

26.1.14 A circuit breaker having an instantaneous response as indicated in [6.5.8](#) shall be capable of passing the 100-percent calibration test with the instantaneous response set at its minimum setting, and the other tests with the instantaneous response set at its maximum setting, except as noted in Adjustable instantaneous trip calibration test, [26.2.5](#), note b of [Table 26.4](#) and note a of [Table 26.12](#).

26.1.15 For tests made with ac, a circuit having the rated frequency of the circuit breaker shall be used. If the specified frequency is in the range of 50 to 60 Hz, or if no frequency is indicated, a 48 – 62 Hz circuit shall be used. If the specified frequency is 400 Hz, a 380 – 420 Hz circuit shall be used. See 400 Hz Rated Circuit Breakers, Section [36](#) for testing 400 Hz rated circuit breakers.

26.1.16 Separately operable circuit breakers in a common base shall not be considered as multipole circuit breakers but shall be treated throughout as individual circuit breakers. When a 2-pole circuit breaker consists of poles constructed so as to trip independently, not common trip, each pole shall be treated as a single pole circuit breaker during the calibration tests.

26.1.17 Separately-operable single-pole circuit breakers shall be treated as individual circuit breakers even though they may have a common housing.

26.1.18 While normally 1-, 2-, 3-, and 4-pole constructions will require individual representative sets of samples, it may be possible in certain instances, where constructions are basically identical, to represent other than the pole construction being tested.

26.1.19 If a single-pole circuit breaker is rated at 120/240 V ac or 125/250 V dc, see [6.5.3](#), two such circuit breakers shall be tested together in the intended manner as a 2-pole independent-trip circuit breaker in the overload, endurance, interrupting, and dielectric voltage-withstand test described below. Two such "pairs" of circuit breakers constitute a set.

26.1.20 In determining if a circuit breaker complies with the test requirements, the device shall be mounted or supported as in service and tested under conditions approximating those of intended operation, except as otherwise noted.

26.1.21 If a circuit breaker is marked for both copper and aluminum conductors, all tests shall be conducted using copper conductors. If not marked for both copper and aluminum conductors, all tests shall be conducted using the conductor type marked on the circuit breaker.

26.1.22 At the conclusion of any test sequence, there shall be no malfunction of functional parts of the circuit breaker as determined by successful completion of the tests required for a specific sequence. It shall not be necessary to open test samples to perform a visual inspection to determine compliance.

26.1.23 When wires are used to connect a circuit breaker for test, the tightening torque applied to the circuit breaker terminals shall not exceed the value marked on the circuit breaker.

26.1.24 A 2-pole common trip circuit breaker that has an additional marking to indicate acceptability on a 3-phase, corner-grounded, delta circuit shall be caused to control 3-phase test circuits during the overload and endurance tests and both single and 3-phase circuits during the interrupting test. See [47.1.21](#).

26.1.25 Except for single-pole circuit breakers tested singly, if a circuit breaker is not marked "line" and "load", one sample of each set tested, or one additional sample, shall be connected with the line and load connections reversed during the overload, endurance, and interrupting tests. When an additional sample is used, it shall be subjected to the initial 200-percent calibration, the trip-out, and the dielectric voltage-withstand tests.

26.1.26 In the overload, endurance, and interrupting tests, a circuit breaker shall be mounted within the smallest metal enclosure that will be used in actual service; except that for the endurance test, an enclosure shall not be required if the vertical surface on which it is mounted is metal, unless there are features which would affect the performance of the circuit breaker if not mounted within an enclosure. The door or cover and any other openings including used and unused openings shall be closed on the outside of the enclosure by means of tape. However, any ventilating openings specified and permitted by this Standard for circuit breakers rated 400 A or more, see [47.1.20](#), need not be closed. If the inside of the enclosure is painted, the paint shall be scraped off on the inside surface of the metal enclosure in areas of the vents of the circuit breaker and where an arc is likely to strike. A nonconducting enclosure shall be used if the circuit breakers are marked as precluding use in a metal enclosure as required by [47.1.19](#).

26.1.27 In the overload, endurance, and interrupting tests, a fuse acceptable for branch circuit protection shall be connected between the enclosure or mounting surface, see [26.1.26](#), and one line to indicate arc over as indicated in [26.11.4.1.14](#) and [Figure 26.1](#), [Figure 26.6](#) and [Figure 26.7](#), respectively. The fuse shall be a 30 A nonrenewable type, having a voltage rating not less than the rating of the device being tested. The connection of the fuse shall be made to the load side of the limiting impedance by means of a 10 AWG (5.3 mm²) wire not more than 1.829 m (6 feet) in length. The enclosure or mounting surface shall not be otherwise electrically connected.

Figure 26.1
Overload Test Connection Diagrams

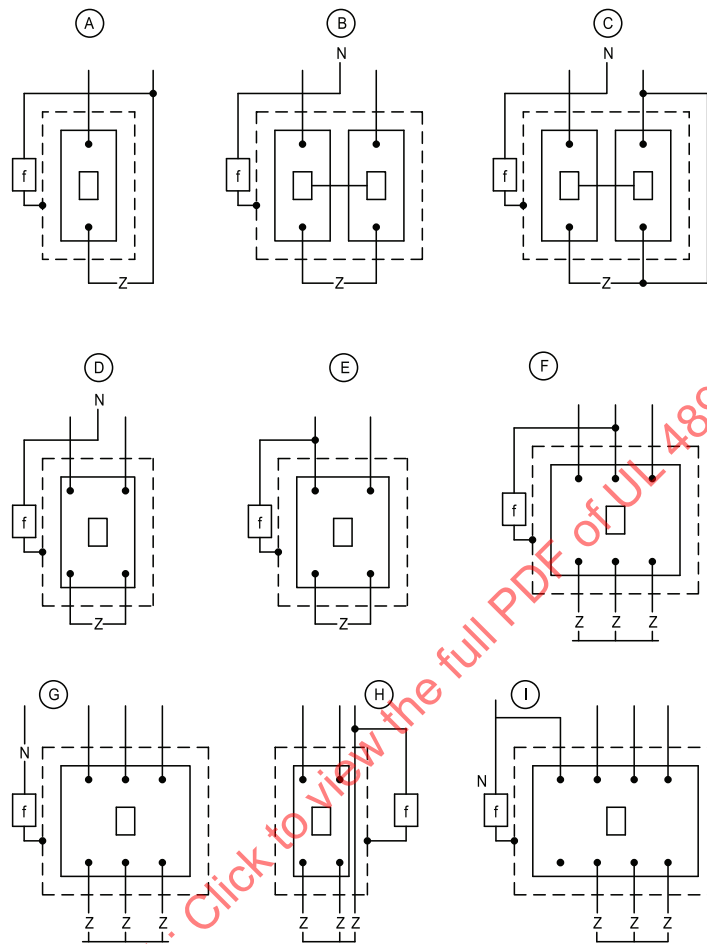

su1347

- A – 1-Pole
- B, C – 1-Pole "Tested in Pairs" (also represents 2-Pole independent-trip type circuit breaker)
- D – 2-Pole Common-Trip "start" (120/240, 125/250 V) Rating
- E – 2-Pole Common-Trip Rating other than D
- F – 3-Pole
- G – 3-Pole wye-connected system ratings
- H – 2-Pole Common-Trip for 3-Phase Rating
- I – 4-Pole wye-connected system ratings
- N – Neutral
- Z – Load Impedance
- f – 30 A "ground" Fuse – Enclosure

26.1.28 During the overload and endurance tests, circuit breakers rated 150 A and less with dependent manual operation shall be operated with an operating speed, during actuation, of 0.1 m/sec ± 25 percent, this speed being measured at the extremity when and where the operating means of the test apparatus touches the actuating means of the circuit breaker under test. For rotary knobs, the angular velocity shall correspond substantially to the above conditions, referred to the speed of the operating means (at its extremities) of the circuit breaker under test.

26.1.29 Standard circuit breakers shall be subjected to the requirements in the following Supplements as indicated:

- a) Annex [G](#) – Marine Circuit Breakers (Not for Canada): Circuit breakers intended for marine use in accordance with USCG Electrical Systems regulations subchapters 33 CFR, Part 183 and USCG electrical engineering regulations subchapter J (46 CFR, Parts 110-113) shall comply with Sections [26](#) – [45](#) except as revised by Annex [G](#).
- b) Annex [H](#) – Naval Circuit Breakers (Not for Canada): Circuit breakers intended for use aboard non-combatant and auxiliary naval ships shall comply with Sections [26](#) – [45](#) except as revised by Annex [H](#).
- c) Annex [I](#) – UPS Circuit Breakers: Circuit breakers intended for use with uninterruptible power supplies (UPS) shall comply with Sections [26](#) – [45](#) except as revised by Annex [I](#).
- d) Annex [J](#) – Classified Circuit Breakers (US only): Circuit breakers intended for use as alternates for specified circuit breakers for use with specified panelboards shall comply with Sections [26](#) – [45](#) except as revised by Annex [J](#).
- e) Annex [K](#) – Electronic Trip Circuit Breakers: Electronic trip circuit breakers provided with programmable components for overcurrent protection, trip settings, current ratings, and the like, other than those circuit breakers covered in Section [29](#) or Section [30](#), shall additionally comply with Annex [K](#).
- f) Annexes [L](#) and [M](#) – Electronic Trip Circuit Breakers: Circuit breaker trip units employing electronic circuit components shall additionally comply with the applicable EMC requirements of Annexes [L](#) and [M](#).
- g) Annex [N](#) – Molded-Case Circuit Breakers with Additional Motor Overload Protection: Motor Overload Protection Circuit breakers shall comply with Sections [26](#) – [45](#) except as revised by Annex [N](#).

26.2 Calibration tests

26.2.1 General

26.2.1.1 To determine if a multipole circuit breaker complies with the requirements of [26.2.2](#) for operation on 200 percent of rated current, each pole shall be tested separately. To determine if a multipole circuit breaker complies with the requirements of [26.2.3](#) and [26.2.4](#), all poles shall be loaded equally, except as indicated in [26.1.17](#).

26.2.1.2 To determine if a circuit breaker rated 226 – 400 A complies with the requirements of [26.2.2](#) and [26.2.3](#), the procedure shall be as follows. For the X Sequence, if interchangeable trip units are involved, two samples of the frame and three samples of the trip unit shall constitute a set for the 200- and 135-percent initial calibration tests at 25 °C (77 °F). The two trip units having the shortest tripping time during the 135-percent calibration test at 25 °C (77 °F) and two frames shall be used for the remainder of the test sequence. For the Y and Z Sequences, two samples of the frame and two samples of the trip unit shall constitute a set. For the X Sequence, if noninterchangeable trip units are involved, three samples shall constitute a set for the 200- and 135-percent tests. The two samples having the shortest tripping time

during the 135-percent calibration test at 25 °C (77 °F) shall be used for the remainder of the test sequence. For the Y and Z Sequences, two samples shall constitute a set. If X-Y-Z Sequences are combined, the procedure described for the X Sequence shall be followed.

26.2.1.3 To determine if a circuit breaker rated 401 – 1600 A complies with the requirements of [26.2.2](#) and [26.2.3](#), the procedure shall be as follows. For the X Sequence, if interchangeable trip units are involved, one sample of the frame and three samples of the trip unit shall constitute a set for the 200- and 135-percent initial calibration tests at 25 °C (77 °F). The trip unit having the shortest tripping time during the 135-percent calibration test at 25 °C (77 °F) and one frame shall be used for the remainder of the test sequence. For the Y and Z Sequences, one frame and one trip unit shall constitute a set. For the X Sequence, if noninterchangeable trip units are involved, three samples shall constitute a set for the 200- and 135-percent tests. The sample having the shortest tripping time during the 135-percent calibration test at 25 °C (77 °F) shall be used for the remainder of the test sequence. For the Y and Z Sequences, if noninterchangeable trip units are involved, one sample shall constitute a set. If the X-Y-Z Sequences are combined, the procedure described for the X Sequence shall be followed.

26.2.1.4 Calibration tests of a circuit breaker may be made at any voltage, using either ac or dc, taking into consideration the characteristics of the circuit breaker and the possible conditions of use. A device not specifically marked for either dc or ac shall be subjected to the 100-percent test with ac and may be subjected to the 135- and 200-percent test with dc. A circuit breaker rated only for a specific frequency other than in the range of 50/60 Hz, or dc, shall be tested at the rated frequency, or dc, or both, as appropriate.

26.2.1.5 Notwithstanding [26.2.1.4](#), if it can be shown by comparison tests that the ac and dc calibration times are essentially the same, then either an ac or dc current source may be used.

26.2.1.6 The conductors specified in [26.1.21](#) shall be of the size indicated in [Table 6.1](#) and no less than 1.219 m (4 feet) in length, except that an accommodating fixture may be used for circuit breakers rated 100 A or less. For a circuit breaker or a circuit breaker frame with an interchangeable trip unit rated more than 30 A but not more than 125 A, the wire size shall be based on the temperature rating of the wire as indicated by the marking on the circuit breaker or trip unit. Where a dual wire temperature rating is marked, 60/75 °C (140/167 °F), the test shall be conducted with both size wires or the most adverse one, if it can be clearly determined.

26.2.1.7 Calibration tests of a circuit breaker shall be conducted with the temperature of the ambient air at 25 ±3 °C (77 ±5 °F), except that the 100-percent calibration test required at 40 °C (104 °F) shall be conducted with the temperature of the ambient air at 40 ±3 °C (104 ±5 °F). In addition, an ambient compensated circuit breaker shall be subjected to 200- and 135-percent calibration tests with the temperature of the ambient air at 40 ±3 °C (104 ±5 °F), the 135-percent test being conducted immediately after the circuit breaker has carried its rated current until constant temperatures have been reached.

26.2.1.8 In conducting calibration tests at 40 ±3 °C (104 ±5 °F), as indicated in [26.2.1.7](#), the circuit breaker, with leads attached shall be terminated in its intended manner and shall be mounted throughout the tests on a vertical surface in an oven, compartment, or room. The ambient temperature shall be measured as indicated in [26.4.1.7](#). The 200-percent calibration test shall be made when the temperature at the points shown in [Figure 26.2](#) – [Figure 26.5](#) becomes constant. After the 200-percent calibration test has been completed, rated current shall be passed through the circuit breaker until the temperature on the circuit breaker becomes constant, at which time the 135-percent calibration test shall be made.

Figure 26.2
Connection for Bolt-On Circuit Breaker Rated Less Than 1600 A

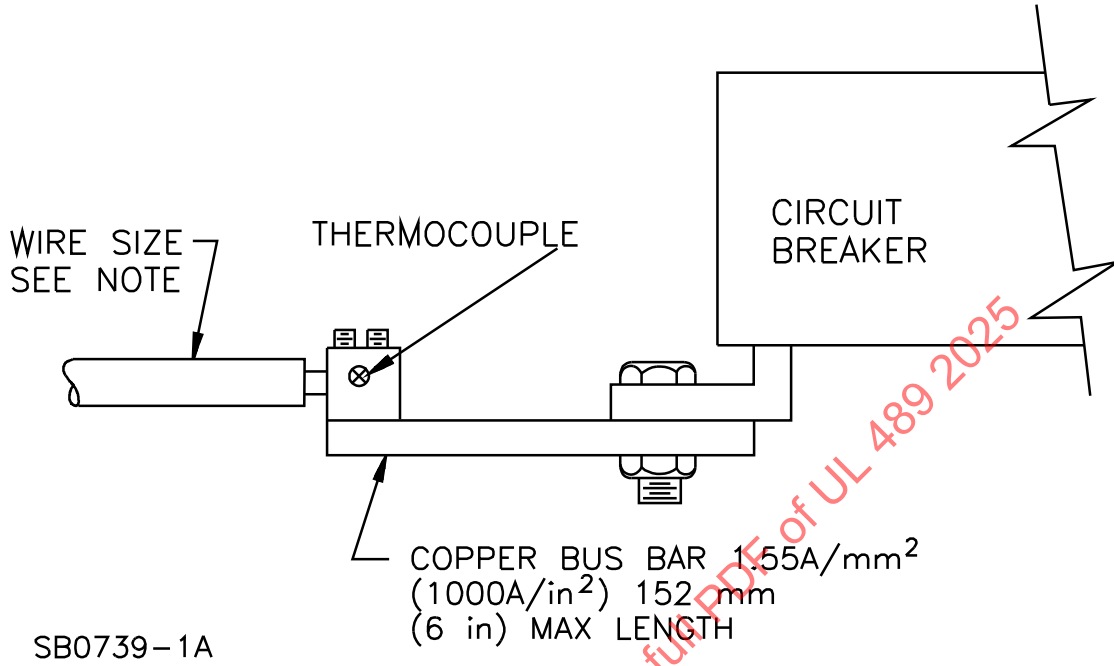

Note: Wire size in accordance with [Table 6.1](#).

Figure 26.3
Connection for Plug-In Circuit Breakers

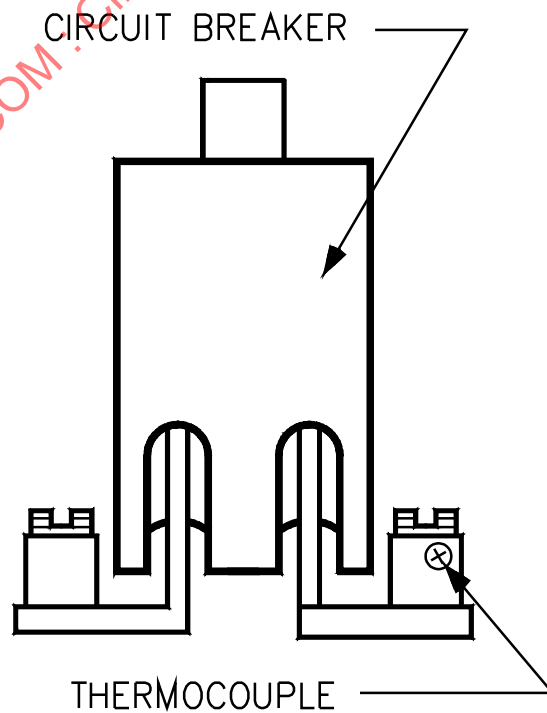

SB0736-1

Figure 26.4
Connection for Circuit Breaker with Extension Member

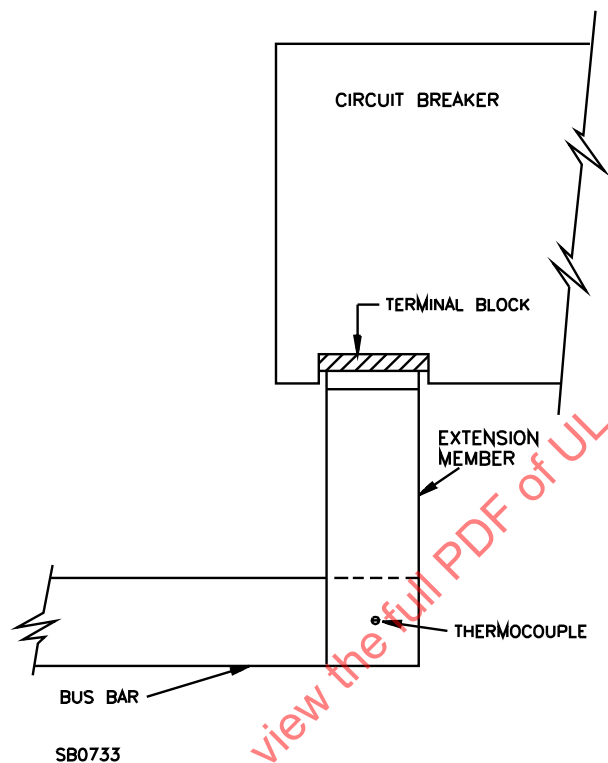

SB0733

Figure 26.5

Connection of Circuit Breaker with Bus Bars

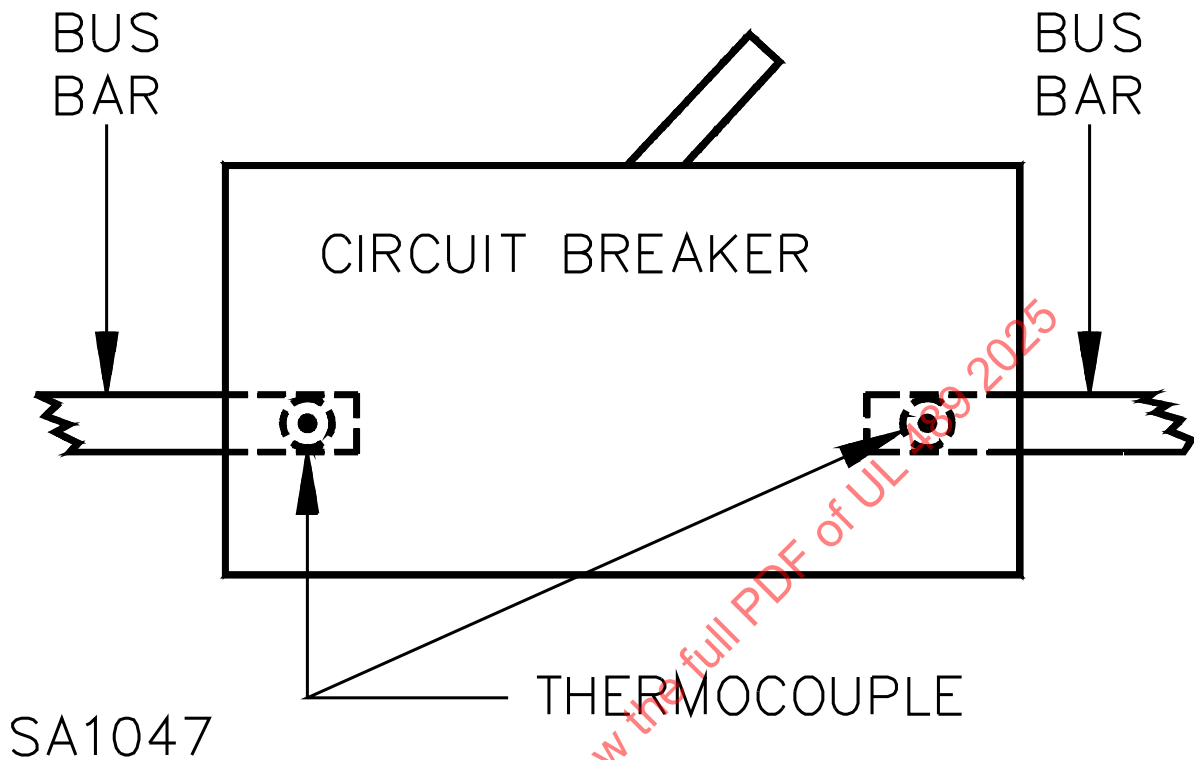

26.2.2 200 percent calibration test

26.2.2.1 Starting with the test sample at the ambient temperature indicated in [Table 26.2](#), a circuit breaker carrying 200 percent of its rated current shall trip within the time limits given in [Table 26.3](#). See [26.2.1.7](#).

Table 26.3
Automatic Tripping Time – 200 Percent Rated

Current rating (I_n) in amperes	Maximum tripping time in minutes
0 – 30 ^a	2
31 – 50	4
51 – 100	6
101 – 150	8
151 – 225	10
226 – 400	12
401 – 600	14
601 – 800	18
801 – 1000	20
1001 – 1200	24
1201 – 1600	26

Table 26.3 Continued on Next Page

ULSE INC. COPYRIGHTED MATERIAL – NOT AUTHORIZED FOR FURTHER REPRODUCTION OR DISTRIBUTION WITHOUT PERMISSION FROM ULSE INC.

Table 26.3 Continued

Current rating (I_n) in amperes	Maximum tripping time in minutes
1601 – 2000	28
Over 2000	30

^a For circuit breaker frames rated more than 250 V, the maximum tripping time may be 3 minutes.

26.2.3 135 percent calibration test

26.2.3.1 A circuit breaker carrying 135 percent of its rated current in accordance with [Table 26.2](#) shall trip within 1 hour for a device rated at 50 A or less, and within 2 hours for a device rated at more than 50 A. Unless otherwise directed, the test sample shall be at the ambient temperature indicated in [Table 26.2](#) at the start of the test. See [26.2.1.7](#).

26.2.4 100 percent calibration test

26.2.4.1 A circuit breaker shall be capable of carrying 100 percent of its rated current without tripping until temperatures become constant. This test may be conducted concurrently with the temperature test. See [26.4.1.4](#) and [26.4.1.11](#).

26.2.5 Adjustable instantaneous trip calibration test

26.2.5.1 In a circuit breaker that has an adjustable instantaneous release as indicated in [6.5.8](#), the automatic tripping at the maximum setting shall be within the range of 80 – 130 percent of the marked tripping current. At the minimum setting, tripping shall be within the range of 80 – 130 percent of the marked tripping current.

26.2.5.2 To determine if a circuit breaker complies with the requirement of [26.2.5.1](#), tests shall be made using one of the following techniques. This test shall be performed at both the maximum and minimum settings of the instantaneous response. Each pole shall be tested separately three times at both the maximum and minimum settings. The average of the three tests on any pole shall be considered to be the tripping current of that pole.

- a) Ramp Method – The test current at the beginning of the test shall be 70 percent of the setting, and the current is then to be increased rapidly until the circuit breaker trips by means of the instantaneous response.
- b) Pulse Method – The test current shall be set at 80 percent of the marked trip setting and closed so that there is minimum asymmetry. The duration of the pulse shall be at least 6 cycles. The test current shall be increased in 5 percent increments. If the circuit breaker trips at 80 percent, the test current shall be reduced by 5 percent to demonstrate that the circuit breaker does not trip within 6 cycles.
- c) Other Methods – Another method that is found to give an accurate indication of the trip point shall be permitted.

26.2.6 Thermal memory retention test

26.2.6.1 A circuit breaker that has an electronic trip unit shall additionally be subjected to the following:

- a) Conduct the 200 percent calibration test, see [26.2.2](#). There shall be no auxiliary power on the trip unit.

b) Re-close the circuit breaker within a time twice the time-delay setting and repeat the 200 percent calibration test. The tripping time shall be at least 30 percent less than the value previously recorded in (a).

26.3 Overload test

26.3.1 A circuit breaker shall be capable of performing successfully when operated under the overload conditions indicated in [26.3.2](#) – [26.3.14](#). There shall be no electrical or mechanical breakdown of the device and the fuse indicated in [26.1.27](#) connected to indicate arc-over to the enclosure or grounded metal shall not have cleared.

26.3.2 A circuit breaker shall be operated as shown for circuit breakers in [Table 26.4](#) making and breaking 600 percent of its rated current, but no less than 150 A, unless the inherent impedance of the circuit breaker will not provide the 150 A at rated voltage. In this case, the maximum current passed at rated voltage shall be used. If the circuit breaker does not latch at the specified rate of operation, the rate may be reduced sufficiently so that the circuit breaker will just remain latched.

Table 26.4
Overload Test Operations

Frame size amperes	Number of operations			Number of cycles of operation per minute
	Circuit breakers			
	Close and open manually ^{a,b,c}	Close manually, open automatically ^e	Switches	
100 or less	35	15	50	6
101 – 150	50 ^d	– ^e	50	5
151 – 225	50	–	50	5
226 – 1600	50	–	50	1 ^e
1601 – 2500	25	–	25	1 ^e
2501 – 6000	28 ^f	–	28 ^f	1 ^f

NOTE: The operations may be performed by a machine simulating manual operation.

^a If the test sample trips during manual operation, it is still considered as a manual operation.

^b At the option of the manufacturer, the adjustable instantaneous response of a circuit breaker rated 400 A or more may be adjusted to less than the maximum position.

^c The minimum closed time shall be one cycle, unless the sample trips.

^d In the case of a multipole breaker without a common trip, and rated at more than 100 A, 35 cycles of operation shall be made manually and 15 automatically as specified in [26.3.14](#).

^e Operation may be conducted in groups of 5, with 15 minutes maximum between groups.

^f Three operations at 600 percent of rating at the rate of 1 cycle per minute, followed by 25 operations at 200 percent of rating at the rate of 1 cycle per minute (may be conducted in groups of 5 with 15 minutes maximum between groups).

26.3.3 The line terminals shall be connected to a supply circuit as indicated below, and the load terminals shall be connected to the necessary impedance. The open circuit voltage of the supply circuit shall be not less than 100 percent nor more than 105 percent of the rated voltage of the circuit breaker, except that a higher voltage may be used if agreeable to all concerned parties. Except as permitted by [26.3.4](#), the current capacity of the supply circuit shall be such that the closed-circuit voltage across the circuit breaker and load with 600 percent of the rated current of the circuit breaker flowing is within 15 percent of the rated voltage of the circuit breaker.

26.3.4 The closed-circuit voltage across the circuit breaker shall be permitted to deviate by more than 15 percent from the rated voltage of the circuit breaker if the supply circuit complies with the requirements for

recovery voltage, as indicated for interrupting tests, using a load equal to the overload or if the supply circuit is considered to be acceptable for the interrupting test.

26.3.5 Wiring diagrams illustrating the test of circuit breakers under overload conditions are indicated in [Figure 26.1](#). Refer to explanation of test methods and circuit characteristics given in this clause and [26.3.8 – 26.3.14](#). All conductors of an ac circuit shall pass through the same knockout, or all line conductors through one knockout and all load conductors through another knockout. Where parallel conductors are used, more than one knockout shall be permitted to be used if an equal number of conductors from each phase and from the same line or load side are routed through each knockout.

26.3.6 A circuit breaker intended for use on a system having one conductor grounded shall be tested with the enclosure, if of metal, connected to the grounded conductor through a fuse described in [26.1.26](#). If a circuit breaker is intended for use on other types of systems, the enclosure shall be connected through a similar fuse to the live pole least likely to strike to ground.

26.3.7 A circuit breaker intended for use on a dc system, see [26.1.7](#), shall be tested with dc and with the device connected so that the enclosure will be positive in potential with regard to the nearest arcing point. The dc circuit shall have a time constant not less than 0.003 second.

26.3.8 Except as specified in [26.3.9](#), a circuit breaker intended for use on an ac system shall be tested with ac with an air core inductive load. The power factor of the load shall be from 0.45 to 0.50 lagging except as noted in [26.3.14](#). Reactive components of the load shall be permitted to be paralleled, but no reactances shall be connected in parallel with resistances, except that an air-core reactor in any phase shall be permitted to be shunted by resistance, the loss of which is approximately 1 percent of the total power consumption in that phase.

26.3.9 An iron-core reactor shall be permitted to be used if the maximum test current is not more than 225 A and the current wave shape at maximum current is such that the ratio of peak-to-rms values is equal to 1.414 ± 5 percent (essentially sinusoidal). If referee tests are necessary, they shall be conducted using air-core reactors in accordance with [26.3.8](#).

26.3.10 For the overload test and for the endurance test, see [26.5.3](#), the resistance per phase in which the power loss is approximately 1 percent of the total power consumption in that phase will be as indicated in [Table 26.5](#).

Table 26.5
Shunting Resistance Per Phase

	Shunting resistance per phase in Ohms	
	Power factor 0.45 – 0.50	Power factor 0.750 – 0.80
Single phase	$\frac{163 E}{I}$	$\frac{52 E}{I}$
Three phase	$\frac{94 E}{I}$	$\frac{30 E}{I}$

E = Closed circuit line potential in volts.
I = Line current in Amperes.

26.3.11 Circuit characteristics are normally determined using laboratory type meters. Where required because of high current conditions, the circuit shall be determined by oscillographic or equivalent means as described in Interrupting Test, [26.7](#). It is not necessary that a circuit breaker be in the circuit when making the circuit determination, so long as during the test it is shown that the circuit breaker is