



# UL 399

## STANDARD FOR SAFETY

### Drinking Water Coolers

[ULNORM.COM](https://www.ulnorm.com) : Click to view the full PDF of UL 399 2024

[ULNORM.COM](https://ULNORM.COM) : Click to view the full PDF of UL 399 2024

UL Standard for Safety for Drinking-Water Coolers, UL 399

Eighth Edition, Dated March 30, 2017

### **Summary of Topics**

***This revision of ANSI/UL 399 dated February 28, 2024 includes a change in requirements for Compliance to UL 4200A for Water Coolers Using Button Cell Batteries; [18.2](#).***

Text that has been changed in any manner or impacted by ULSE's electronic publishing system is marked with a vertical line in the margin.

The revised requirements are substantially in accordance with Proposal(s) on this subject dated January 19, 2024.

All rights reserved. No part of this publication may be reproduced, stored in a retrieval system, or transmitted in any form by any means, electronic, mechanical photocopying, recording, or otherwise without prior permission of ULSE Inc. (ULSE).

ULSE provides this Standard "as is" without warranty of any kind, either expressed or implied, including but not limited to, the implied warranties of merchantability or fitness for any purpose.

In no event will ULSE be liable for any special, incidental, consequential, indirect or similar damages, including loss of profits, lost savings, loss of data, or any other damages arising out of the use of or the inability to use this Standard, even if ULSE or an authorized ULSE representative has been advised of the possibility of such damage. In no event shall ULSE's liability for any damage ever exceed the price paid for this Standard, regardless of the form of the claim.

Users of the electronic versions of UL's Standards for Safety agree to defend, indemnify, and hold ULSE harmless from and against any loss, expense, liability, damage, claim, or judgment (including reasonable attorney's fees) resulting from any error or deviation introduced while purchaser is storing an electronic Standard on the purchaser's computer system.

No Text on This Page

[ULNORM.COM](https://ulnorm.com) : Click to view the full PDF of UL 399 2024

**MARCH 30, 2017**  
(Title Page Reprinted: February 28, 2024)



**ANSI/UL 399-2024**

1

## **UL 399**

### **Standard for Drinking-Water Coolers**

First Edition – December, 1956  
Second Edition – November, 1968  
Third Edition – September, 1972  
Fourth Edition – July, 1978  
Fifth Edition – July, 1987  
Sixth Edition – June, 1993  
Seventh Edition – August, 2008

#### **Eighth Edition**

**March 30, 2017**

This ANSI/UL Standard for Safety consists of the Eighth Edition including revisions through February 28, 2024.

The most recent designation of ANSI/UL 399 as an American National Standard (ANSI) occurred on February 28, 2024. ANSI approval for a standard does not include the Cover Page, Transmittal Pages, and Title Page. Any other portions of this ANSI/UL standard that were not processed in accordance with ANSI/UL requirements are noted at the beginning of the impacted sections.

Comments or proposals for revisions on any part of the Standard may be submitted to ULSE at any time. Proposals should be submitted via a Proposal Request in the Collaborative Standards Development System (CSDS) at <https://csds.ul.com>.

Our Standards for Safety are copyrighted by ULSE Inc. Neither a printed nor electronic copy of a Standard should be altered in any way. All of our Standards and all copyrights, ownerships, and rights regarding those Standards shall remain the sole and exclusive property of ULSE Inc.

**COPYRIGHT © 2024 ULSE INC.**

No Text on This Page

[ULNORM.COM](https://ULNORM.COM) : Click to view the full PDF of UL 399 2024

## CONTENTS

### INTRODUCTION

1	Scope .....	9
2	Units of measurement .....	9
3	Undated references .....	9
4	<i>Reserved for future use</i> .....	9
5	Glossary .....	9
6	Installation And Operating Instructions .....	14

### CONSTRUCTION

7	General .....	15
8	Nonmetallic Material .....	16
	8.1 Classification .....	16
	8.2 Ignition Sources .....	16
	8.3 Application and Location .....	19
9	Assembly .....	19
	9.1 General .....	19
	9.2 Pressurized beverage product system .....	19
	9.3 Mechanical protection .....	19
	9.4 Electrical protection .....	21
10	Barriers .....	25
11	Accessories .....	25
12	Enclosures .....	26
	12.1 General .....	26
	12.2 Doors and covers .....	29
	12.3 Enclosures exposed to weather .....	30
13	Field Supply Connections for Permanently Connected Water Coolers .....	32
	13.1 General .....	32
	13.2 Terminals .....	33
	13.3 Leads .....	33
	13.4 Grounding .....	34
14	Supply Connections – Cord Connected Equipment .....	35
15	Internal Wiring And Wiring Methods .....	38
16	Separation of Circuits .....	42
17	Bonding for Grounding .....	43
18	Button or Coin Cell Batteries .....	45

### ELECTRICAL COMPONENTS

19	Current-Carrying Parts .....	45
20	Insulating Material .....	46
21	Switches And Controllers .....	46
22	Remotely Operated Water Coolers .....	51
23	Motors .....	52
24	Motor Overload Protection .....	55
	24.1 General .....	55
	24.2 Protection of single-phase nonhermetic motors .....	55
	24.3 Protection of single-phase hermetic refrigerant motor-compressors .....	55
	24.4 Protection of three-phase motors .....	56
	24.5 Protective electronic circuits .....	56
25	Electric Water Heaters .....	57
	25.1 Heater elements .....	57

25.2	Water heater thermal cutoffs .....	58
26	Valves and Solenoids .....	59
27	Capacitors .....	59
28	Transformers .....	60
29	Batteries and Battery Chargers .....	61
30	Circuit Breakers, Fusing Resistors and Supplementary Protectors .....	61
31	Connectors .....	61
32	Electrical Cable, Conduit and Tubing .....	61
33	Electrical Insulation Systems .....	62
34	Electromagnetic Interference Filters .....	62
35	Fuses and Fuseholders .....	62
36	Lighting Systems .....	63
37	Optical Isolators and Semiconductor Devices .....	63
38	Outlet Boxes .....	64
39	Power Supplies .....	64
40	Receptacles .....	64
41	Terminal Blocks .....	65
42	Wireways, Auxiliary Gutters and Associated Fittings .....	65
43	Ultraviolet (UV) Radiation Systems .....	65
44	Across-The-Line Capacitors, Antenna-Coupling Components, Line-Bypass Components and Fixed Capacitors for Use in Electronic Equipment .....	65
45	Information Technology Equipment .....	65

## SPACINGS

46	High-Voltage Circuits .....	66
47	Extra Low-Voltage Circuits .....	68
48	Alternate Spacings – Clearances and Creepage Distances .....	68

## REFRIGERATION SYSTEM

49	Refrigerant .....	69
50	Pump-Down Capacity .....	69
51	Refrigerant Tubing and Fittings .....	69
52	Refrigerant-Containing Parts .....	70
53	Pressure-Limiting Device .....	71
54	Pressure Relief .....	72
	54.1 General .....	72
	54.2 Required discharge capacity .....	72
	54.3 Relief valves .....	72

## THERMOELECTRIC SYSTEM

55	General .....	73
----	---------------	----

## WATER SYSTEM

56	General .....	73
----	---------------	----

## PERFORMANCE

57	General .....	73
	57.1 Instrumentation .....	73
	57.2 Ambient temperature .....	74
58	Tests on Nonmetallic Materials .....	74

58.1	General.....	74
58.2	Burnout test – Impedance protected motors.....	75
58.3	Fastener strength test.....	76
59	Test Voltage.....	77
60	Leakage Current Test – Cord Connected Water Coolers.....	77
61	Input Test.....	79
62	Temperature and Pressure Test.....	80
63	Dielectric Voltage-Withstand Test.....	84
64	Condenser Fan Motor Failure Test.....	85
65	Condenser Water Failure Test.....	86
66	Overflow Test.....	86
67	Spill Test.....	87
68	Rain Test.....	87
69	Stability Test.....	90
70	Static Loading Test.....	90
70A	Cabinet/Enclosure Static Load Test.....	90
70B	Cabinet/Enclosure Impact Test.....	92
71	Ozone Test.....	93
72	Strain Relief Test.....	93
73	Water Heating Protective Controls Tests.....	94
	73.1 Endurance test.....	94
	73.2 Calibration test.....	94
74	Overload and Endurance Test for Operating Controls.....	95
75	Burnout Test.....	96
	75.1 Water heater.....	96
	75.2 Thermoelectric water coolers.....	97
	75.3 Other components.....	98
76	Overvoltage and Undervoltage Tests.....	99
77	Current Overload Test – Bonding Conductors and Connections.....	99
78	Insulation Resistance Test.....	100
	78.1 Water heaters.....	100
	78.2 Thermal and/or acoustical insulating material.....	100
79	Limited Short-Circuit Test.....	100
	79.1 General.....	100
	79.2 Motor overload protective devices.....	102
	79.3 Bonding conductors and connections.....	102
	79.4 Motor circuit conductors and connections.....	102
79A	Switch Mode Power Supply Units – Overload Test.....	102
80	Protective Devices – Maximum Continuous Current Test.....	103
81	Strength Tests – Pressure Containing Components.....	104
	81.1 General.....	104
	81.2 High-side parts.....	105
	81.3 Low-side parts.....	105
	81.4 Leakage at gaskets or seals.....	105
	81.5 Water-heating tanks.....	106
	81.6 Pressurized beverage product system.....	106
	81.7 Water-containing parts for pressure-type water coolers.....	106
82	Start-To-Discharge Test.....	106
83	Protective Electronic Circuit Tests.....	107
	83.1 General.....	107
	83.2 Fault conditions abnormal test.....	107
	83.3 Electromagnetic compatibility (EMC) tests.....	108
	83.4 Programmable component reduced supply voltage test.....	109
	83.5 Fuse-link test.....	110
84	Accelerated Aging Test – Electric Heaters.....	111
85	Reliability Test – Heater Terminations.....	111

UL 399.COM - Click to view the full PDF of UL 399 2024

86	Accelerated Aging Tests on Gaskets, Sealing Compounds, and Adhesives.....	111
87	Ultraviolet Irradiance Test.....	113
88	Metallic Coating Thickness Test.....	113
89	Marking Label Adhesion Tests.....	115
	89.1 General.....	115
	89.2 Oven-aging test.....	115
	89.3 Immersion test.....	116
	89.4 Standard-atmosphere test.....	116
	89.5 Unusual-condition exposure test.....	116
90	Refrigerant Identification Tests.....	116
	90.1 General.....	116
	90.2 Infrared analysis.....	116
	90.3 Gas chromatography analysis.....	117

## MANUFACTURING AND PRODUCTION TESTS

91	Pressure Tests.....	117
92	Production Fatigue Test.....	118
93	Production Line Dielectric Voltage-Withstand Tests.....	118
94	Production Line Grounding Continuity Tests.....	120
95	Annual Refrigerant Identification.....	121
96	Protective Electronic Circuit Test.....	121

## MARKING

97	General.....	121
98	Accessories.....	124
99	Permanently Connected Water Coolers.....	124
100	Cord Connected Water Coolers.....	128

## SUPPLEMENT SA – SANITATION REQUIREMENTS FOR SELF CONTAINED DRINKING-WATER COOLERS

### INTRODUCTION

SA1	Scope.....	129
-----	------------	-----

### CONSTRUCTION

SA2	Bubbler Nozzle and Guard.....	129
SA3	Air Gap.....	129
SA4	Top or Bowl.....	129

### PERFORMANCE

SA5	Nozzle Flow Control Test.....	130
-----	-------------------------------	-----

## SUPPLEMENT SB – REQUIREMENTS FOR DRINKING WATER COOLERS EMPLOYING A FLAMMABLE REFRIGERANT IN THE REFRIGERATING SYSTEM

SB1	Scope.....	131
SB2	Definitions.....	131
SB3	General.....	132
SB4	Construction.....	132
	SB4 1 General.....	132

SB4.2 Tubings and fittings .....	133
SB5 Performance .....	133
SB5.1 Leakage test.....	133
SB5.2 Ignition protection test .....	136
SB5.3 Temperature test.....	137
SB5.4 Scratch test .....	137
SB6 Marking, Installation and Operating Instructions .....	139
SB6.1 Marking.....	139
SB6.2 Installation and operating instructions .....	140

**APPENDIX A Clarifications**

**APPENDIX B Operating and Protective (“Safety Critical”) Control Functions (Normative)**

ULNORM.COM : Click to view the full PDF of UL 399 2024

No Text on This Page

[ULNORM.COM](https://ULNORM.COM) : Click to view the full PDF of UL 399 2024

## INTRODUCTION

### 1 Scope

1.1 These requirements cover self-contained drinking-water coolers employing hermetic refrigerant motor-compressors or thermoelectric water chilling systems and designed for connection to alternating-current circuits rated not greater than 600 volts in accordance with the National Electrical Code, NFPA 70. The following types of water coolers are included within the scope of this Standard:

- a) Those supplying cold water or both cold and hot water;
- b) Battery operated;
- c) Those employing flammable refrigerant as defined in Supplement [SB](#); and
- d) Those provided with ultraviolet (UV) radiation lamp systems in which the UV wavelengths are 200 nm or greater; however, the effectiveness of the water treatment by the UV radiation is not covered by these requirements.

1.2 These requirements do not include additional requirements applicable to equipment designed for use in hazardous locations as defined in the National Electrical Code, NFPA 70.

1.3 A product that contains features, characteristics, components, materials, or systems new or different from those covered by the requirements in this standard, and that involves a risk of fire, electric shock, or injury to persons shall be evaluated using the appropriate additional component and end-product requirements as determined necessary to maintain the acceptable level of safety as originally anticipated by the intent of this standard. A product whose features, characteristics, components, materials, or systems conflict with specific requirements or provisions of this standard cannot be judged to comply with this standard. Where considered appropriate, revision of requirements shall be proposed and adopted in conformance with the methods employed for development, revision, and implementation of this standard.

### 2 Units of measurement

2.1 If a value for measurement is followed by value in other units in parentheses, the second value may be only approximate. The first stated value is the requirement.

### 3 Undated references

3.1 Any undated reference to a code or standard appearing in the requirements of this standard shall be interpreted as referring to the latest edition of that code or standard.

### 4 Reserved for future use

### 5 Glossary

5.1 For the purpose of this standard, the following definitions apply.

5.2 **ACCESSORY** – An optional electrical device or other component, such as a superstructure, intended for installation in or connection to a water cooler for the purpose of modifying or supplementing the functions of the water cooler. It may be factory installed or intended for installation by the user.

5.3 **\*ADJUSTABLE SPEED DRIVE** – A combination of power converter, inverter, motor, and motor-mounted auxiliary devices such as encoders, tachometers, thermal switches and detectors, air blowers, heaters, and vibration sensors.

\*Reprinted with permission from NFPA 70-2011®, *National Electrical Code*®, Copyright © 2010, National Fire Protection Association, Quincy, MA. This reprinted material is not the complete and official position of the NFPA on the referenced subject, which is represented only by the standard in its entirety.

5.4 \*ADJUSTABLE SPEED DRIVE SYSTEM – An interconnected combination of equipment that provides a means of adjusting the speed of a mechanical load coupled to a motor. A drive system typically consists of an adjustable speed drive and auxiliary electrical apparatus.

\*Reprinted with permission from NFPA 70-2011®, *National Electrical Code*®, Copyright © 2010, National Fire Protection Association, Quincy, MA. This reprinted material is not the complete and official position of the NFPA on the referenced subject, which is represented only by the standard in its entirety.

5.5 BARRIER, ELECTRICAL – A partition for the isolation of high-voltage electrical components or for separating ignition sources from flammable materials.

5.6 BARRIER, MECHANICAL – A rigid partition for the isolation of moving parts and ultraviolet (UV) radiation, or protection of wiring.

5.7 BASIC INSULATION – The insulation applied to live parts to provide protection against electric shock.

5.8 CABINET – The part of the product that provides physical protection to insulated wiring, enclosures, moving parts, motors, enclosed electrical parts, refrigeration tubing or other parts that may cause injury to persons.

5.8.1 CAPACITOR, CLASS Y – Capacitor or resistor-capacitor unit of a type suitable for use in situations where failure of the capacitor could lead to danger of electric shock. (Examples would include capacitors connected across the primary and secondary circuits where electrical isolation is required to prevent an electric shock or between hazardous live parts and accessible parts.)

5.9 CAPILLARY TUBE – Device made of tubing with an outer diameter of less than 3/16 inch (4.7 mm) and used to reduce the pressure of the refrigerant between the condenser and evaporator. It also regulates the refrigerant flow.

#### 5.10 CIRCUITS, ELECTRICAL:

Extra-Low-Voltage – A circuit supplied by:

- 1) An AC potential of not more than 42.4 volts peak (30 V rms) and power of 100 VA or less; or
- 2) A DC potential of 30 V supplied by a primary battery; or
- 3) A Class 2 transformer, as defined by the National Electrical Code, NFPA 70; or
- 4) A combination of an isolating transformer and fixed impedance which, as a unit, complies with all performance requirements for a Class 2 transformer.

High-Voltage – A circuit involving a potential of not more than 600 volts and having circuit characteristics in excess of those of an extra-low-voltage circuit.

5.11 COMPONENT – A device or fabricated part of the drinking water cooler covered by the scope of a safety standard dedicated to that purpose. If incorporated in a drinking water cooler, a product that is otherwise typically field installed (e.g. luminaire) is considered to be a component. Unless otherwise specified, materials that compose a device or fabricated part, such as aluminum or copper, are not considered components. Generally, components are incomplete in construction features or restricted in

performance capabilities. Such components are intended for use only under specific, limited conditions, such as certain temperatures not exceeding specified limits.

5.12 CONTROL, OPERATING – A device or assembly of devices, the operation of which starts or regulates the end product during normal operation. For example, a thermostat, the failure of which a thermal cutout/limiter or another layer of protection would mitigate the potential risk of fire, electrical shock, or injury to persons, is considered an operating control. Operating controls are also referred to as “regulating controls”. Appendix B specifies control functions that are not considered to result in a risk of fire, electric shock or injury to persons.

5.13 CONTROL, PROTECTIVE – A device or assembly of devices, the operation of which is intended to reduce the risk of electric shock, fire or injury to persons during normal and reasonably anticipated abnormal operation of the appliance. For example, a thermal cutout/limiter, or any other control/circuit relied upon for normal and abnormal conditions, is considered a protective control. Protective controls are also referred to as “limiting controls” or “safety controls” and are investigated under normal and single-fault conditions. Appendix B specifies control functions that are considered to result in a risk of fire, electric shock or injury to persons.

5.14 DOUBLE INSULATION – An insulation system comprised of basic insulation and supplementary insulation, with the two insulations physically separated and arranged so that they are not simultaneously subjected to the same deteriorating influences (temperature, contaminants, and the like) to the same degree.

5.15 ELECTRONIC COMPONENT – A part in which electrical conduction is achieved principally by electrons moving through a vacuum, gas or semiconductor. A Metal Oxide Varistor (MOV) is considered to be an electronic component, but neon indicators are not.

5.16 ELECTRONIC DISCONNECTION – The de-energizing of a load within an appliance by an electronic device of a circuit. No electro-mechanical component having an air gap, such as a switch, contactor or relay is used to de-energize the load.

5.17 ENCLOSURE – The part of the product that does one or more of the following:

- a) Isolates ignition sources,
- b) Renders inaccessible all or any parts of the equipment that may otherwise present a risk of electric shock,
- c) Retards propagation of flame initiated by electrical disturbances within.

5.18 FUNCTIONAL PART – A part other than an enclosure or cabinet used to maintain the intended relative physical position of fixed or moving parts, or maintain the integrity of the structure.

5.19 GROUNDING, FUNCTIONAL – Grounding of a point in an appliance which is necessary for a purpose other than safety.

5.20 IGNITION SOURCE – Any high-voltage electrical component not located within an enclosure.

5.21 MAXIMUM OPERATING CURRENT (MOC) – The current resulting when an electric motor and adjustable speed drive or drive system are operated under any conditions such as maximum speed/maximum load, maximum speed/minimum load, minimum speed/minimum load, minimum speed/maximum load, including locked-rotor such that current to the motor/adjustable speed drive or drive system is at a maximum.

5.22 MAXIMUM RATED CURRENT (MRC) – The current resulting when a hermetic refrigerant motor-compressor and adjustable speed drive or drive system are operated under any conditions such as maximum speed/maximum load, maximum speed/minimum load, minimum speed/minimum load, minimum speed/maximum load, including locked-rotor such that current to the motor-compressor/adjustable speed drive or drive system is at a maximum.

5.23 MOTOR CONTROLLER – Any device normally used to start and stop a motor, such as a switch, thermostat, pressure limiting control, or the like.

5.24 NONFUNCTIONAL PART – A part of the product that does not perform a specific function.

5.25 NONFUNCTIONAL PART, SMALL – A nonfunctional part that does not occupy a volume greater than 0.12 in<sup>3</sup> (2 cm<sup>3</sup>), does not have a dimension greater than 1.2 inches (3 cm), is located so it cannot propagate flame from one area to another and does not connect a possible source of ignition to other ignitable parts.

5.26 PRECOOLER – A heat exchanger within a water cooler intended to remove heat from the inlet water before the inlet water enters the evaporator. Heat is removed from the inlet water by the cooled outlet (waste) water. The precooler has separate passes between water circuits so that the inlet and outlet water cannot mix.

5.27 PROTECTIVE ELECTRONIC CIRCUIT (PEC) – An electronic circuit that prevents a risk of fire, electric shock or injury to persons under abnormal operating conditions.

5.28 START-TO-DISCHARGE PRESSURE – The pressure at which a relief valve begins to discharge, typically the pressure where the first bubbles can be seen when a valve is immersed in water.

5.29 SUPPLEMENTARY INSULATION – An independent insulation provided in addition to the basic insulation to protect against electric shock in case of mechanical rupture or electrical breakdown of the basic insulation.

5.29.1 SWITCH MODE POWER SUPPLY UNIT – Electronic device incorporating transformer(s) and electronic circuitry(ies), that converts electrical power into single or multiple power outputs by rapidly switching a solid-state device on and off. It may also isolate the input circuit from the output circuit and regulate and/or convert the output voltage and current. The device may consist of one or more individual units with identical or different waveforms and frequencies including dc output.

©IEC. This material is from IEC 61558-1 Ed. 3.0 b:2017 with permission of the American National Standards Institute (ANSI) on behalf of the International Electrotechnical Commission. All rights reserved.

5.30 TEMPERATURE LIMITING CONTROL – A control which serves only to prevent abnormal temperature and is not intended to function during normal operation.

5.31 TEMPERATURE REGULATING CONTROL – A control which regulates temperature and is intended to function frequently during normal operation.

5.32 THERMISTOR – A thermally sensitive semiconductor resistor, which shows over at least part of its resistance/temperature characteristic a significant non-linear change in its electrical resistance with a change in temperature. A thermistor may be either of the positive temperature coefficient (PTC) type or of the negative temperature coefficient (NTC) type.

5.33 ULTIMATE STRENGTH – The highest stress level that a refrigerant-containing component can tolerate without rupture.

5.34 ULTRAVIOLET (UV) RADIATION SYSTEM – Equipment that directly generates UV radiation and generally used to enhance purification of the drinking water. The system typically consists of a lamp assembly with UV bulb(s) producing ultraviolet radiation in wavelengths of 200 nm or greater.

5.34.1 VOLTAGE FOLDBACK – A circuit design feature intended to protect the power supply output transistors. When overcurrent is drawn by the load, the supply reduces the output voltage and current to within the safe power dissipation limit of the output transistors.

5.35 WATER COOLER – A unit that consists of a refrigeration system that is intended to cool potable water.

5.36 WATER COOLER, AGAINST-THE-WALL – Freestanding units intended to be placed in close proximity to a wall.

5.37 WATER COOLER, BOTTLE TYPE – A water cooler which employs a bottle or reservoir for storing potable water that is intended to be cooled and utilizes a faucet or similar means to dispense the chilled water.

5.38 WATER COOLER, BUILT-IN – These are intended to be permanently mounted and enclosed to some degree by structural parts of a building. A wall-insert water cooler is an example of a “built-in” type.

5.39 WATER COOLER, CAFETERIA – Pressure-type coolers intended primarily for use in cafeterias and restaurants for dispensing water rapidly into glasses and pitchers.

5.40 WATER COOLER, COLUMN MOUNT – Remote water coolers intended for installation on a column or post usually at an elevated position above the floor.

5.41 WATER COOLER, COUNTER-SUPPORTED – A water cooler that is physically supported by a counter, table or bench during the performance of its intended function.

5.42 WATER COOLER, FREESTANDING – Intended for installations in which the structural parts of a building neither enclose nor functionally obstruct the water cooler.

5.43 WATER COOLER, HOT- AND COLD-TYPE – These include means for heating and dispensing potable water.

5.44 WATER COOLER, PRESSURE TYPE – A water cooler intended to be plumbed to a potable water source that is supplied under pressure. The water cooler utilizes a faucet or similar means to dispense the water.

5.45 WATER COOLER, REMOTE – Pressure-type coolers designed for use with remotely installed bubblers or other dispensing means.

5.46 WATER COOLER, SELF-CONTAINED – Completely factory-made and factory-tested assemblies to which no refrigerant-containing parts are connected in the field.

5.47 WATER COOLER, THERMOELECTRIC – A water cooler in which the water is chilled using the Peltier Effect such that a direct current supply source is applied to a semiconductor thermoelectric module creating a temperature gradient which transfers heat from one surface to another.

5.48 WATER COOLER, WALL-HUNG – Water coolers intended to be suspended from a wall.

## 6 Installation And Operating Instructions

6.1 A water cooler shall be provided with installation and operating instructions that contain the following:

- a) Directions and information as deemed by the manufacturer to be necessary for the safe installation, maintenance, and use of the water cooler;
- b) Roughing-in dimensions for electrical connections of permanently connected units and for plumbing connections of pressure-type units;
- c) Guidelines for ensuring protection of the water cooler by means of a ground-fault circuit interrupter; and
- d) For pressure type coolers the maximum water supply line pressure shall be included.

6.2 A copy of the manufacturer's installation and operating instructions, or equivalent information intended to accompany each water cooler, shall be furnished with the sample submitted for investigation. These instructions shall be used as a guide in the examination and test of the water cooler.

6.3 If a water cooler is intended for use with a field-installed accessory, instructions for installing the accessory shall be provided on or with the accessory and shall warn the user that:

- a) The water cooler must be disconnected from the source of electrical supply before attempting the installation; and
- b) The accessory is intended for use only with the specific water cooler for which the accessory is marked.

6.4 A double insulated thermoelectric water cooler provided with a 2-blade, polarized attachment plug shall be provided with the following or equivalent in the manufacturer's installation and operating instructions: "To reduce the risk of electric shock, this appliance has a polarized plug (one blade is wider than the other). This plug will fit in a polarized outlet only one way. If the plug does not fit fully in the outlet, reverse the plug. If it still does not fit, contact a qualified electrician to install the proper outlet. Do not change the plug in any way."

6.5 A water cooler intended to employ a UV system shall be provided with instructions specifying the following or equivalent:

- a) Information indicating the cover or covers that provide access to the UV radiation system along with the following or equivalent statement: "Caution: UV Light Source – Disconnect the electrical source of supply to the UV radiation before opening cover."
- b) Information for the replacement of the UV lamps which shall include the wattage, voltage, lamp type and the designation number; and
- c) Instructions pertaining to the proper handling and disposal of UV lamps.

6.6 The instructions for a water cooler employing R744 (carbon-dioxide) shall specify that:

- a) The water cooler be installed in a well-ventilated area and that installation in confined spaces shall be avoided; and
- b) Users and/or installers follow requirements in the R744 material safety data sheet (MSDS) and in the Safety Standard for Refrigeration Systems, ASHRAE 15.

6.7 In reference to [22.4](#), the instructions for a water cooler intended to be remotely operated and in which the water cooler attachment plug and receptacle serve as the manual means for disconnecting remote operation commands, external communication or data signals shall specify that unplugging the water cooler disconnects the remote functions.

6.8 The instructions for a water cooler, and any intended accessory(ies), having two power supply cords:

- a) Shall indicate that the water cooler uses two cords and caution against unplugging only one cord during movement, testing or repair of the product; and,
- b) That may have different attachment plug caps shall state that different attachment plugs are used and shall specify the electrical rating of each plug. If individual branch circuits are involved, the instructions shall state that individual branch circuits are to be employed to supply the product and electrical ratings of each branch circuit shall be specified.

## CONSTRUCTION

### 7 General

7.1 Ferrous metal parts used to support or retain electrical components in position shall be protected against corrosion by metallic or nonmetallic coatings, such as plating or painting.

7.2 All nonmetallic parts, excluding small nonfunctional parts shall comply with [8.1](#), [8.2](#), and [Table 58.1](#).

7.3 In addition to the requirement in [7.2](#), nonmetallic materials that serve as electrical insulation or that directly support live parts shall comply with the requirements for electric insulation in the Standard for Polymeric Materials – Use in Electrical Equipment Evaluations, UL 746C.

7.4 The hot water dispense device on a hot- and cold-type water cooler shall require at least two distinct operations to dispense hot water.

7.5 A component shall:

- a) Comply with the safety standard covering that component;
- b) Be used in accordance with its rating(s) established for the intended conditions of use;
- c) Be used within its established use limitations or conditions of acceptability;
- d) Comply with the applicable requirements of this end product standard; and
- e) Not contain mercury.

*Exception: A component of a product covered by this standard is not required to comply with a specific component requirement that:*

- a) Involves a feature or characteristic not required in the application of the component in the product, or*
- b) Is superseded by a requirement in this standard, or*
- c) Is separately investigated when forming part of another component, provided the component is used within its established ratings and limitations.*

7.6 A component that is also required to perform other necessary functions, such as overcurrent protection, ground-fault circuit interruption, surge suppression, any other similar functions, or any

combination thereof, shall comply additionally with the requirements of the applicable standard(s) covering products that provide those functions.

## 8 Nonmetallic Material

### 8.1 Classification

8.1.1 Materials shall be classified with respect to flammability characteristics that are established by the tests specified in the Standard for Tests for Flammability of Plastic Materials for Parts in Devices and Appliances, UL 94.

8.1.2 Materials shall be assigned flammability ratings based on greatest to least resistance to flame and are identified as: 5VA, 5VB, V-0, V-1, V-2, HF-1, HF-2, HB, and HBF.

8.1.3 In reference to [8.1.2](#), the assigned flammability rating shall be appropriate for the material-use application in accordance with [8.2](#) and [Table 58.1](#).

8.1.4 Nonmetallic materials exposed to UV radiation shall comply with the Ultraviolet Light Exposure requirements in the Standard for Polymeric Materials – Use in Electrical Equipment Evaluations, UL 746C except that the testing shall be conducted based on the actual UV radiation to which the nonmetallic material is exposed rather than the twin enclosed carbon-arc or xenon-arc conditioning. The test shall be conducted for not less than 1000 hours. Following the UV exposure, the materials shall comply with the tests specified in [Table 58.1](#) based on the use application for each nonmetallic material.

### 8.2 Ignition Sources

8.2.1 Parts formed from nonmetallic materials rated HB or HBF and positioned as shown in [Figure 8.2](#) shall be separated from ignition sources by means of a barrier, extending at least to the boundary surface of the space whenever such parts are located:

- a) Below an ignition source and within Space A; and
- b) Above an ignition source and within Space B; and
- c) In the vertical plane relative to an ignition source and within Space C.

Figure 8.1  
Articulate probe with web stop

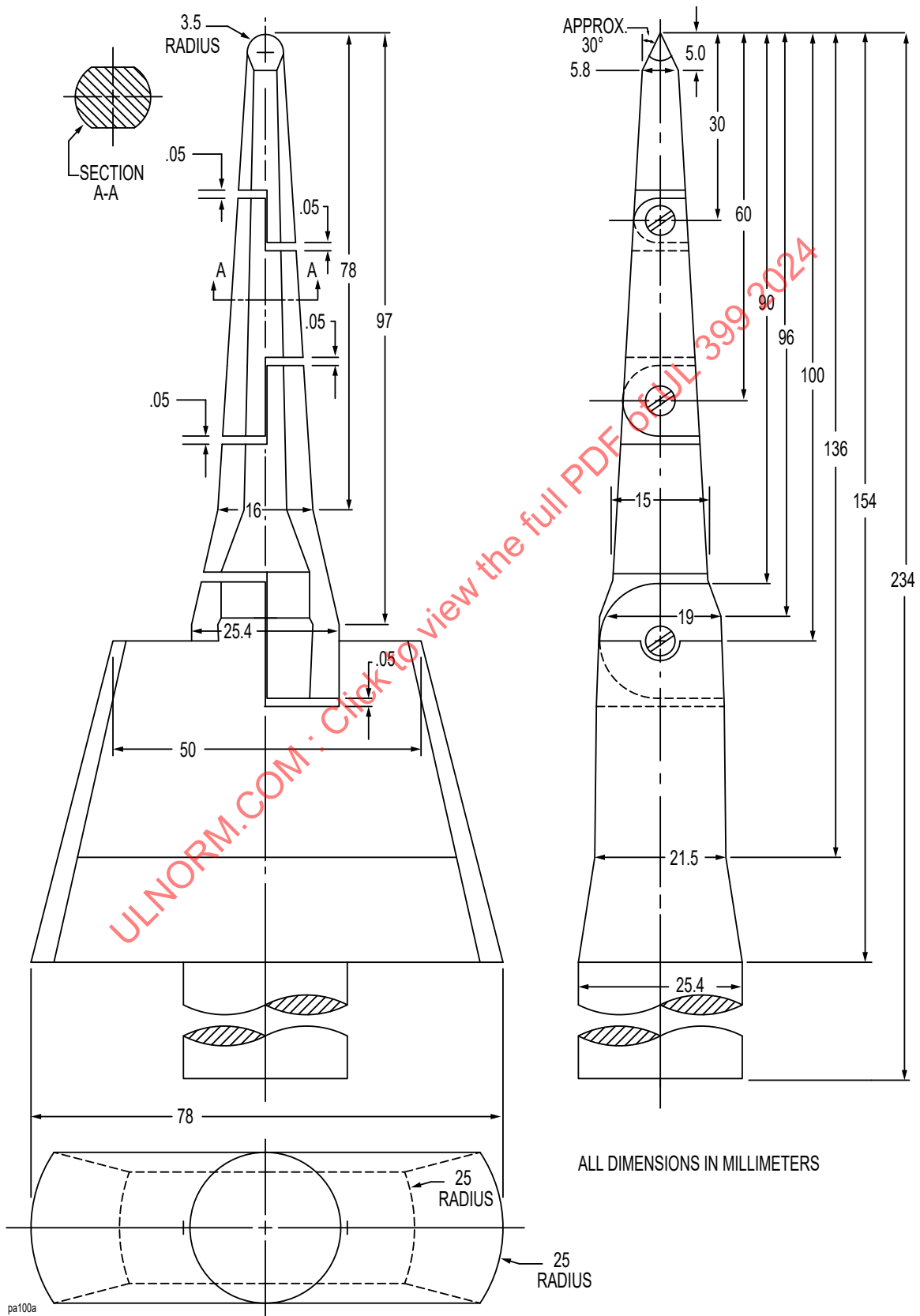

- 8.2.2 The HB or HBF materials referenced by 8.2.1 shall be located such that the distance between:
- High-voltage wiring not employing VW-1 and the HB or HBF materials shall be a minimum of 2 inches (51 mm), and
  - Any other ignition source and the HB or HBF materials shall be a minimum of 4 inches (102 mm).
- 8.2.3 In reference to 8.2.2 and Figure 8.2, the minimum distance for materials located:
- Above the ignition source shall be as shown in Distance X + Y; and
  - In the vertical plane relative to the ignition source shall be as shown in straight-line Distance Z.

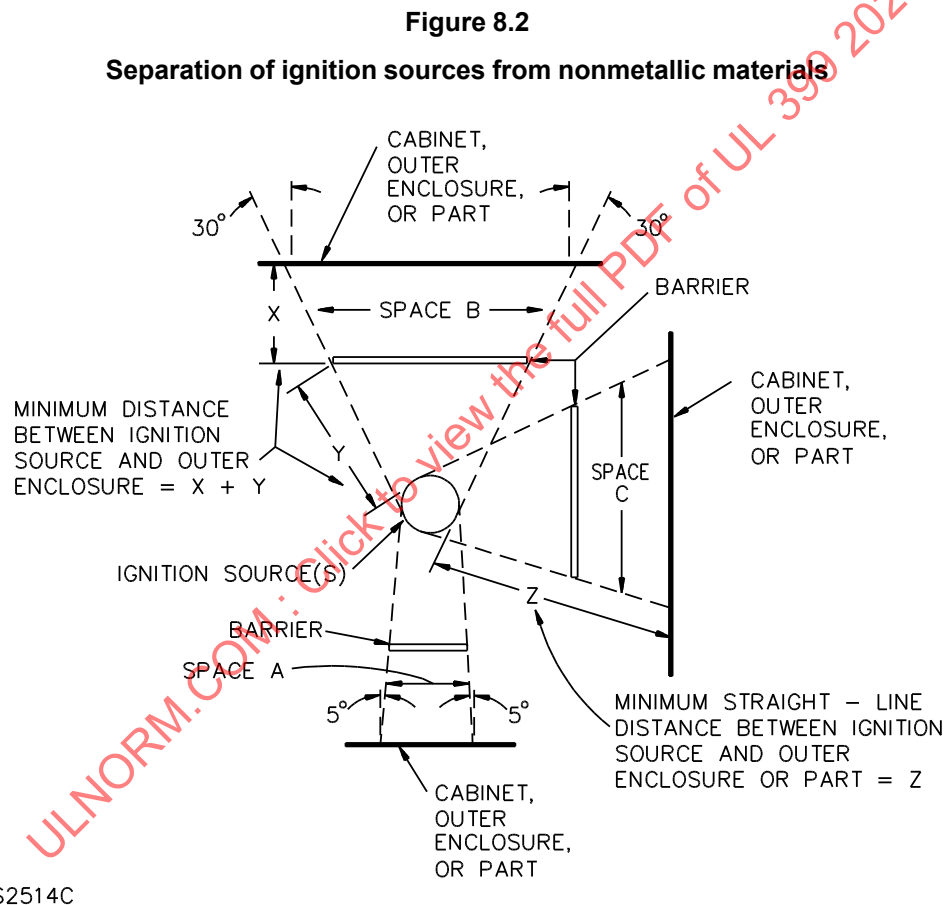

**Notes:**

Space A – Represents the volume below the ignition source determined by a straight line that moves about the ignition source while remaining at the angle of 5 degrees from the vertical and is always so oriented that the volume is maximum.

Space B – Represents the volume above the ignition source determined in the same manner as Space A, except that the angle is 30 degrees from the vertical.

### 8.3 Application and Location

8.3.1 Nonmetallic fasteners used as a part of the enclosure shall comply with the Fastener strength test. See [58.3](#).

8.3.2 The combined total exposed surface area of all small, nonfunctional parts shall not exceed 144 in<sup>2</sup> (929 cm<sup>2</sup>).

8.3.3 When thermal insulation is located between a cabinet and inner liner, the product shall comply with both (a) and (b) or it can comply only with (c):

- a) All holes within the cabinet and inner liner shall be closed,
- b) The cabinet surfaces shall be securely fastened such that the maximum spacing between screws, spot welds, or other securement means does not exceed 6 inches (152.4 mm),
- c) The thermal insulation shall be rated HF-1.

## 9 Assembly

### 9.1 General

9.1.1 A bottle-type water cooler shall be assembled so that removal and replacement of bottles will not result in damage to electrical components and wiring, or to refrigerant-containing components.

9.1.2 Ozone generating equipment installed on drinking water coolers shall comply with the Standard for Water Treatment Appliances, UL 979 and with the Ozone Test of Section [71](#).

9.1.3 If a drinking water cooler contains a refrigerated storage compartment, the compartment shall comply with the requirements in the Standard for Household and Similar Electrical Appliances – Safety – Part 2-24: Particular Requirements for Refrigerating Appliances, Ice-Cream Appliances and Ice-Makers, UL 60335-2-24 that apply to refrigerated compartments.

9.1.4 Wiring and electrical components shall not be exposed to UV radiation.

### 9.2 Pressurized beverage product system

9.2.1 A gas pressure regulator or reducing valve shall comply with the Standard for Compressed Gas Regulators, UL 252.

9.2.2 A pressure-relief valve complying with either [54.3](#) or with the Start-To-Discharge Test in Section [82](#) shall be installed in a pressurized beverage product system. There shall be no shutoff valve between the relief valve and any parts of the system under pressure.

9.2.3 Pressure relief devices in a pressurized product system shall be positioned, located, or baffled so that moisture discharged through the relief device will not wet uninsulated live parts.

9.2.4 A pressurized beverage product system shall comply with the tests in [81.6](#).

### 9.3 Mechanical protection

9.3.1 Louvers and other openings in the enclosure shall be constructed and located to reduce the risk of unintentional contact with moving parts and with hot surfaces that may cause injury to persons. See [9.3.4](#) and [9.3.5](#). Knockouts for entrance of electrical conduit and plumbing may be provided. In determining

compliance with the requirements specified in [9.3.2](#) – [9.3.5](#), parts such as covers, panels, or grilles used as part of the enclosure are to be removed unless tools are required for their removal.

9.3.2 Moving parts, such as fan blades, shall be guarded or enclosed. Parts required for guarding shall be secured by means dependent upon tools for removal unless functioning of the water cooler requires the guard to be in place.

9.3.3 With reference to [9.3.2](#), moving parts are considered to be enclosed when the distance from an opening to the moving part is as specified in [Table 9.1](#). For an opening having a minor dimension intermediate between two of the values included in the table, the distance from the opening to the moving part is determined by interpolation between the corresponding values in the right-hand column of the table. The minor dimension of the opening is determined by the largest hemispherically tipped cylindrical probe that can be inserted through the opening with a force of 5 pounds (22.3 N).

*Exception No. 1: The following areas are considered to be solid surfaces for the purpose of applying this requirement:*

- a) *The bottom of a freestanding unit.*
- b) *The rear of a wall-hung unit.*
- c) *The rear of an against-the-wall unit if, according to the instructions provided with the unit, no gap is allowed between the unit and the wall, and the unit has been tested accordingly.*

*Exception No. 2: A moving part is not to be considered if:*

- a) *The part is unlikely to be contacted through the opening because of the location of fixed components, including baffles, water lines, drain tubes, and the like, or*
- b) *The part is made inoperative, when exposed, through the use of interlocking devices.*

*If more than one method of routing plumbing lines is specified in the installation instructions, all methods are to be evaluated when determining if such lines, as installed, serve as baffles to prevent contact with moving parts.*

**Table 9.1**  
**Dimensions of openings**

Minor dimensions of opening <sup>a</sup> ,		Minimum distance from opening to moving part <sup>b</sup> ,	
inches	(mm)	inches	(mm)
1/4	(6.4)	1/2	(12.7)
3/8	(9.5)	1-1/2	(38.1)
1/2	(12.7)	2-1/2	(63.5)
3/4	(19.1)	4-1/2	(114.0)
1	(25.4)	6-1/2	(165.0)

<sup>a</sup> Openings less than 1/4 inch (6.4 mm) are not to be considered. Openings greater than 1 inch (25.4 mm) shall be designed or located to reduce the risk of unintentional contact with moving parts that may involve injury to persons.

<sup>b</sup> Also applies to thermally hot parts. See [Table 62.1](#).

9.3.4 When tested in accordance with the provisions of the Temperature and Pressure Test, Section [62](#), surfaces that exceed the temperature limit of [Table 62.1](#) (d)(3) and (d)(4) shall be guarded in accordance with [9.3.2](#) and [9.3.3](#). In determining compliance with this requirement, the handle of the hot water spigot

on a hot- and cold-type water cooler is considered to be a surface contacted by persons in the operation of the unit, [Table 62.1\(d\)\(3\)](#). The hot water spigot itself is exempt from this requirement. Surfaces that are recessed or located away from the front of the water cooler are not considered subject to casual contact, see [Table 62.1\(d\)\(4\)](#). Examples of such surfaces include a condenser located at the rear of a freestanding unit and a compressor located over an opening in the bottom of a wall-hung unit.

9.3.5 The sheath of a heater element, as installed in a water cooler, shall be protected against mechanical damage. A copper or steel sheath at least 0.016 inch (0.41 mm) thick is considered to provide such protection. In addition, if the temperature of a heater exceeds the limits permitted by [Table 62.1 \(d\)\(3\)](#) or (d)(4), whichever is appropriate, it shall be guarded in accordance with [9.3.2](#) and [9.3.3](#) to protect persons from coming in contact with it.

#### 9.4 Electrical protection

9.4.1 Louvers and other openings in the enclosure shall be constructed and located to reduce the risk of unintentional contact with uninsulated high-voltage live parts. Knockouts for entrance of electrical conduit and plumbing may be provided. To determine compliance with this requirement, parts such as covers, panels, or grilles used as part of the enclosure are to be removed unless tools are required for their removal or an interlock is provided. See [12.2.1](#).

9.4.2 Where an opening in the enclosure will not permit the entrance of a 3/4 inch (19.1 mm) diameter rod, the probe illustrated in [Figure 9.1](#) shall not touch any uninsulated high-voltage live parts and the probe illustrated in [Figure 9.2](#) shall not touch any film-coated wire when inserted through the opening. The probe shall not pass through grilles, screens, louvers, or the like when a force of 5 pounds (22.3 N) is applied.

**Figure 9.1**  
**Probes**

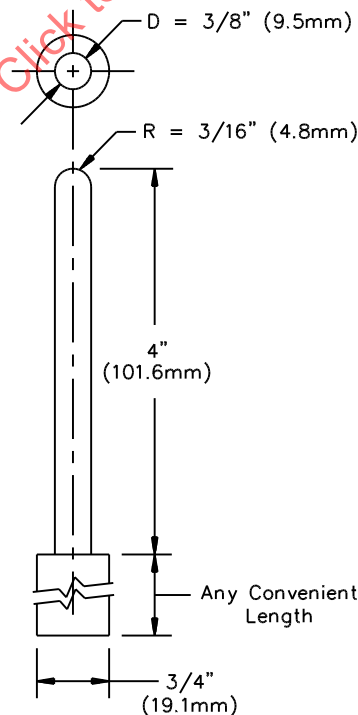

PA170A

**Figure 9.2**  
**Probe**

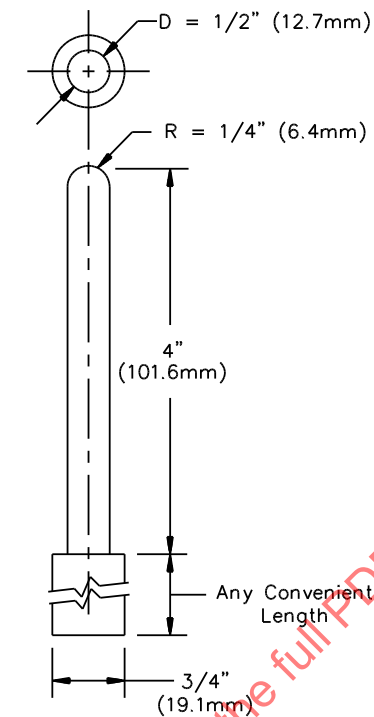

PA170B

9.4.3 Where an opening in the enclosure permits the entrance of a 3/4 inch (19.1 mm) diameter rod, the conditions described in [Figure 9.3](#) shall be used in determining compliance with the requirements. The minor dimension of the opening shall not exceed 1 inch (25.4 mm) in any case.

**Figure 9.3**  
**Opening in enclosure**

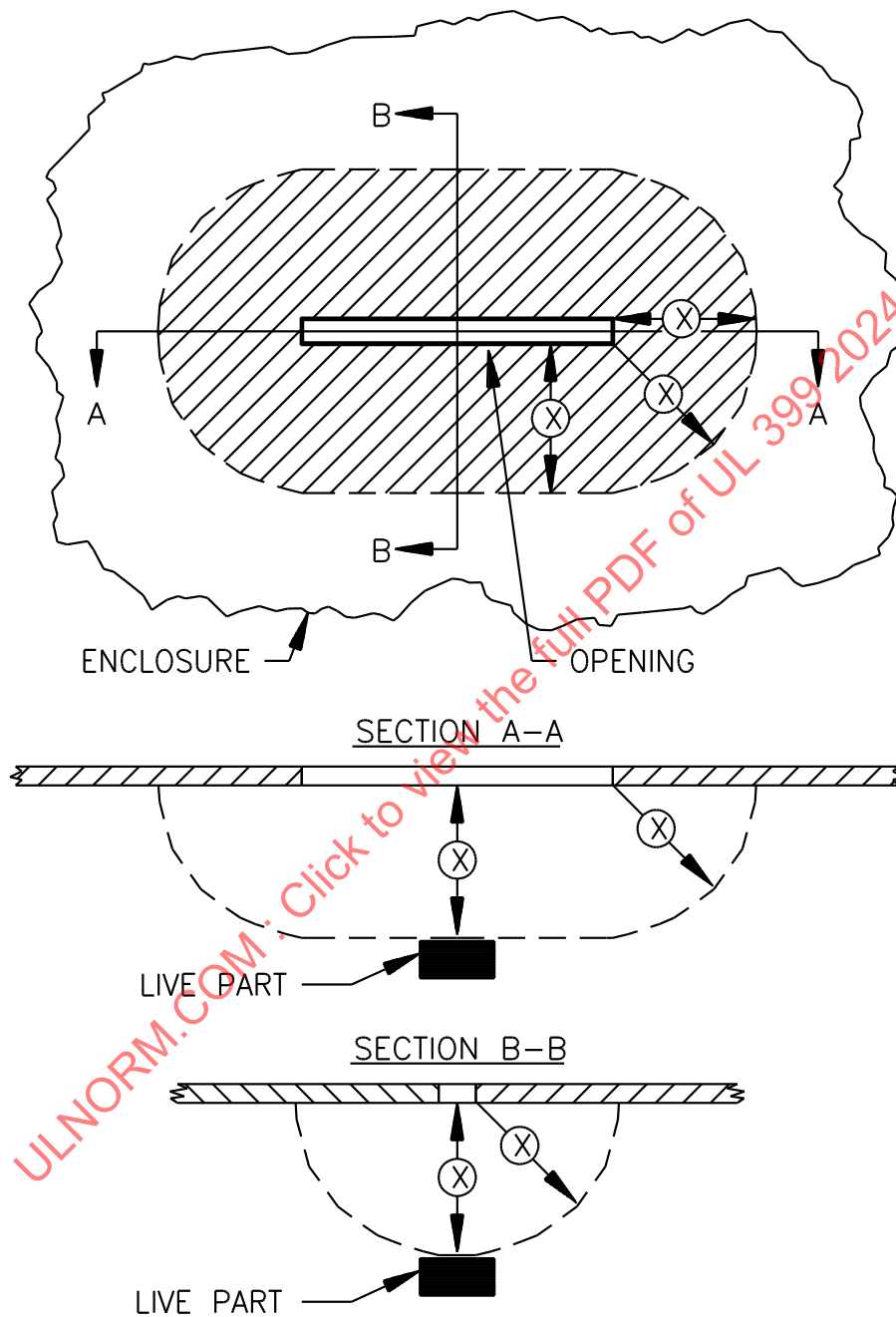

EC100A

The opening is acceptable if, within the enclosure, there is no uninsulated live part or film-coated wire:

(1) less than X inches from the perimeter of the opening, as well as

(2) within the volume generated by projecting the perimeter X inches normal to its plane.

X equals five times the diameter of the largest diameter rod which can be inserted through the opening, but not less than 4 inches (102 mm).

9.4.4 In addition to the requirements of [9.4.2](#) and [9.4.3](#), uninsulated high-voltage live parts inside the enclosure which are likely to be contacted by persons performing operations such as replacing fuses, resetting manual-reset devices, oiling motors, or other such normal service operations shall be located, guarded, or enclosed to reduce the risk of unintentional contact unless tools are required to expose the live part. See [97.13](#).

9.4.5 Electrical components shall be located or enclosed so that uninsulated high-voltage live parts will not be wetted by water due to condensation, splashing, or leakage.

9.4.6 On pressure type water coolers, a drain basin shall be constructed so that overflow due to a blocked drain will not wet uninsulated high-voltage live parts or film-coated wire.

9.4.7 A water reservoir on a bottle type water cooler and waste water receptacles on any type water cooler shall be constructed and located so that overflow will not wet uninsulated high-voltage live parts or film-coated wire.

9.4.8 The Overflow Test, Section [66](#), is to be conducted if it is not evident that the water cooler complies with the provisions of [9.4.6](#) and [9.4.7](#).

9.4.9 A bottle type water cooler shall be constructed so that a liquid spill on the top surface of the unit, during removal or installation of water containers will not wet uninsulated live parts or film-coated wire in line-voltage circuits. A Spill Test, Section [67](#), is to be conducted if it is not evident that the water cooler complies with this requirement.

9.4.10 A switch, attachment-plug receptacle, motor-attachment plug, or similar component shall be secured in position and, except as noted in [9.4.11](#), shall be prevented from turning. See [9.4.12](#).

9.4.11 The requirement that a switch be prevented from turning will be waived if the following conditions are met:

- a) The switch is a plunger or other type that does not tend to rotate when operated. A toggle switch is considered to be subject to forces that tend to turn the switch during the operation of the switch,
- b) Means of mounting the switch make it unlikely that operation of the switch will loosen it,
- c) The spacings are not reduced below the minimum required values if the switch rotates, and
- d) Operation of the switch is by mechanical means rather than direct contact by persons.

9.4.12 With reference to [9.4.10](#), the means for preventing rotation is to consist of more than friction between surfaces. A toothed lock washer that provides both spring take-up and an interference lock is acceptable as means for preventing a small stem-mounted switch or other device having a single-hole mounting means from turning.

9.4.13 An uninsulated high-voltage live part and its support shall be secured to a mounting surface so that it will be prevented from turning or shifting in position if such motion may result in a reduction of spacings below the minimum acceptable values. See Spacings, High-Voltage Circuits, Section [46](#). Friction between surfaces is not acceptable as a means to prevent shifting or turning of a live part, but a lock washer as described in [9.4.12](#) is acceptable.

9.4.14 Flammable or electrically conductive thermal or acoustical insulation shall not contact uninsulated high-voltage live parts. See [78.2.1](#).

## 10 Barriers

- 10.1 A barrier shall be secured to the mounting surface such that tools are required for its removal.
- 10.2 A barrier shall be formed from one or more of the following:
- a) Metal, minimum 0.005 inch (0.13 mm) thick,
  - b) Fiberglass, minimum 0.5 inch (12.7 mm) thick,
  - c) A nonmetallic material rated 5VA,
  - d) A nonmetallic material evaluated to the 127 mm (5 inch) End Product Flame Test as described in UL 746C,
  - e) Any other material or construction determined to be equivalent to items (a) to (d).
- 10.3 In reference to [10.2](#), a nonmetallic barrier exposed to UV radiation shall comply with [8.1.4](#).
- 10.4 In reference to [10.2](#), a rigid backing or a mechanical barrier shall be provided behind these materials unless the materials are determined to be suitably rigid.
- 10.5 A mechanical barrier shall be formed from one or more of the following:
- a) Metal, minimum 0.026 inch (0.66 mm) thick,
  - b) A nonmetallic material which shall be considered a part of the cabinet and which shall comply with the cabinet requirements of [Table 58.1](#),
  - c) Any other material or construction determined to be equivalent to (a) or (b).

## 11 Accessories

- 11.1 A water cooler having provisions for electrical accessories to be attached in the field shall be constructed so that the use of these accessories will not introduce a risk of fire, electric shock, or injury to persons.
- 11.2 The water cooler shall comply with all requirements of this standard with or without the accessory installed. Additional requirements for accessories are in [6.3](#) and [98](#).
- 11.3 Installation of accessories shall:
- a) Be restricted to an arrangement that can be accomplished by means of receptacles and plug-in connectors; and
  - b) Not require the cutting of wiring or the soldering of connections.
- 11.4 An accessory strain-relief means shall be provided for the wiring if there is a possibility of transmitting stress to the terminal connections during installation. The strain-relief shall comply with the Strain Relief Test in Section [72](#).
- 11.5 The accessory wiring connections shall be identified on both the accessory and on the water cooler.
- 11.6 The accessory mounting location shall be:
- a) Identified on the water cooler; or

b) Fixed due to the function of the accessory and its arrangement within the water cooler. In this case, the accessory installation instructions shall specify the mounting location of the accessory.

11.7 Accessories shall be trial-installed. The factors outlined below shall be considered when evaluating the trial-installation of the accessory:

- a) Feasibility of the accessory installation;
- b) Detailed and correct accessory installation instructions; and
- c) The accessory installation complies with [11.1](#) to [11.6](#).

11.8 Accessories intended for connection to a source of field power supply independent of that of the equipment shall comply with the requirements in:

- a) Section [13](#) if intended to be a permanently connected accessory. A permanently connected accessory shall not be used with any supply cord connected equipment.
- b) Section [14](#) if intended to be a cord-connected accessory.

11.9 If an accessory is powered from a source of supply separate from that supplying the water cooler:

- a) The water cooler power supply source shall not provide power to the same control box or electrical panel as the power source supplying the accessory and the water cooler shall be marked as specified in [98.3](#); or
- b) Disconnection of any one supply shall automatically cause de-energization of all circuits within the water cooler and accessory(ies).

## 12 Enclosures

### 12.1 General

12.1.1 Enclosures shall be formed and assembled so that they will have the strength and rigidity necessary to resist the abuses to which they may be subjected without increasing the risk of fire or injury to persons due to total or partial collapse with the resulting reduction of spacings, loosening or displacement of parts, or other serious defects. Enclosures for individual electrical components, outer enclosures, and combinations of the two are considered in determining compliance with this requirement.

12.1.2 Among the factors that are taken into consideration when evaluating an enclosure are:

- a) Mechanical strength,
- b) Resistance to impact, and
- c) Resistance to corrosion.

In addition to these factors, a nonmetallic enclosure or part of an enclosure is evaluated for:

- a) Moisture-absorption properties,
- b) Flammability, and
- c) Resistance to distortion at temperatures to which the material may be subjected under conditions of use.