



UL 2572

STANDARD FOR SAFETY

Mass Notification Systems

[ULNORM.COM](https://ulnorm.com) : Click to view the full PDF of UL 2572 2024

[ULNORM.COM](https://ulnorm.com) : Click to view the full PDF of UL 2572 2024

UL Standard for Safety for Mass Notification Systems, UL 2572

Second Edition, Dated March 28, 2016

Summary of Topics

This revision of ANSI/UL 2572 dated January 10, 2024 is being issued to update the title page to reflect the most recent designation as a Reaffirmed American National Standard (ANS). No technical changes have been made.

Text that has been changed in any manner or impacted by ULSE's electronic publishing system is marked with a vertical line in the margin.

The requirements are substantially in accordance with Proposal(s) on this subject dated November 10, 2023.

All rights reserved. No part of this publication may be reproduced, stored in a retrieval system, or transmitted in any form by any means, electronic, mechanical photocopying, recording, or otherwise without prior permission of ULSE Inc. (ULSE).

ULSE provides this Standard "as is" without warranty of any kind, either expressed or implied, including but not limited to, the implied warranties of merchantability or fitness for any purpose.

In no event will ULSE be liable for any special, incidental, consequential, indirect or similar damages, including loss of profits, lost savings, loss of data, or any other damages arising out of the use of or the inability to use this Standard, even if ULSE or an authorized ULSE representative has been advised of the possibility of such damage. In no event shall ULSE's liability for any damage ever exceed the price paid for this Standard, regardless of the form of the claim.

Users of the electronic versions of UL's Standards for Safety agree to defend, indemnify, and hold ULSE harmless from and against any loss, expense, liability, damage, claim, or judgment (including reasonable attorney's fees) resulting from any error or deviation introduced while purchaser is storing an electronic Standard on the purchaser's computer system.

No Text on This Page

[ULNORM.COM](https://ulnorm.com) : Click to view the full PDF of UL 2572 2024

MARCH 28, 2016
(Title Page Reprinted: January 10, 2024)



ANSI/UL 2572-2018 (R2024)

1

UL 2572

Standard for Mass Notification Systems

First Edition – October, 2011

Second Edition

March 28, 2016

This ANSI/UL Standard for Safety consists of the Second Edition including revisions through January 10, 2024.

The most recent designation of ANSI/UL 2572 as a Reaffirmed American National Standard (ANS) occurred on January 10, 2024. ANSI approval for a standard does not include the Cover Page, Transmittal Pages, and Title Page.

Comments or proposals for revisions on any part of the Standard may be submitted to ULSE at any time. Proposals should be submitted via a Proposal Request in ULSE's On-Line Collaborative Standards Development System (CSDS) at <https://csds.ul.com>.

Our Standards for Safety are copyrighted by ULSE Inc. Neither a printed nor electronic copy of a Standard should be altered in any way. All of our Standards and all copyrights, ownerships, and rights regarding those Standards shall remain the sole and exclusive property of ULSE Inc.

COPYRIGHT © 2024 ULSE INC.

No Text on This Page

ULNORM.COM : Click to view the full PDF of UL 2572 2024

CONTENTS

INTRODUCTION

1 Scope9
 2 Components9
 3 Units of Measurement10
 4 Undated References10
 5 Glossary10

CONSTRUCTION

6 General17
 7 Enclosures17
 7.1 General17
 7.2 Metallic material17
 7.3 Polymeric materials20
 7.4 Covers21
 7.5 Battery compartments22
 7.6 Enclosure openings – General22
 7.7 Enclosure top openings22
 7.8 Enclosure side openings23
 7.9 Enclosure bottom openings28
 8 Internal Materials28
 9 Accessibility of Uninsulated Live Parts, Film-Coated Wire, and Moving Parts29
 10 Mechanical Assembly31
 11 Protection Against Corrosion32
 12 Branch-Circuit Connection32
 12.1 General32
 12.2 Permanently connected33
 12.3 Cord-connected product34
 13 Other Field-Wiring Connections37
 13.1 General37
 13.2 Field-wiring compartment38
 13.3 Class 2 or 3 circuits38
 13.4 Field-wiring terminals (general application)39
 13.5 Field-wiring terminals (qualified application)39
 13.6 Field-wiring leads40
 13.7 Cords and plugs41
 14 Internal Wiring41
 14.1 General41
 14.2 Splices and connections42
 14.3 Connectors and receptacles43
 15 Protective Devices43
 16 Current-Carrying Parts43
 17 Spacings43
 18 Insulating Material45
 19 Printed-Wiring Boards45
 20 End-of-Line Devices46
 21 Voltage-Dropping Resistors46
 22 Coil Windings46
 23 Components46
 23.1 Switches46
 23.2 Lampholders and lamps47
 23.3 Operating mechanisms47

23.4	Across-the-line components	47
24	Batteries	48
24.1	Rechargeable storage-type used as a secondary power source	48
24.2	Primary dry-cell batteries	48
24.3	Lithium batteries	49
25	Grounding for Products Containing High-Voltage Circuits	49
26	Servicing Protection	52
26.1	General.....	52
26.2	Trained service personnel	52
26.3	Antenna terminal discharge assembly	52

PROTECTION AGAINST INJURY TO PERSONS

27	General	53
28	Telescoping Antenna	53
29	Sharp Edges	53
30	Stability	54

PERFORMANCE – GENERAL

31	Details.....	54
31.1	Tests and voltages	54
31.2	Loading.....	55

PERFORMANCE – OPERATION TESTS

32	Specifics.....	55
33	In-Building Mass Notification Systems – General	56
34	In-Building Mass Notification Systems – LOC, ACU, and ECCU.....	58
35	In-Building ECS/MNS Systems – Signal Priority.....	60
36	Wide Area ECS/MNS Systems	61
36.1	General.....	61
36.2	High Power Speaker Array (HPSA).....	63
36.3	Priorities for Evacuation and Relocation Signals.....	65
37	Distributed Recipient Mass Notification Systems (DRMNS)	65
37.1	Control Equipment.....	65
37.2	Premised Based DRMNS – General.....	67
37.3	Modality Types	68
37.4	Type 1: DRMNS Messages to E-mail.....	68
37.5	Type 2: DRMNS Messages to PC Pop-up.....	68
37.6	Type 3: DRMNS Messages to a Web Server Delivering Content.....	69
37.7	Type 4: DRMNS Messages to Instant Message Clients.....	70
37.8	Type 5: DRMNS Messages to SMS Text (short message service).....	70
37.9	Type 7: DRMNS Messages to Phones.....	71
37.10	Type 8: DRMNS Messages to Pagers.....	71
37.11	Type 9: DRMNS Messages to Hand-Held Radios	72
37.12	Type 10: DRMNS Messages to a Social Network.....	72
38	Interfaces	72
38.1	General.....	72
38.2	Abnormal Operations	73
38.3	Limited Energy	74
38.4	Transient Protection.....	74
38.5	Audio Interface Circuits	74
38.6	Technical Configurations (TC) 1 and 2 – General Physical Media Connected Analog Audio & Control Output	74

38.7 Technical Configuration (TC) 3 – Proprietary Interface Data77
 38.8 Technical Configuration (TC) 4 – Isolation Interface77

PERFORMANCE – COMMON REQUIREMENTS

39 Power Supplies 78
 39.1 General..... 78
 39.2 Primary power source 79
 39.3 Secondary power source(s)..... 80
 39.4 Primary Batteries 80
 39.5 Primary Batteries – DRMNS 81
 39.6 Primary Batteries – HPSA 83
 40 Live Voice and Pre-Recorded Message Communication..... 83
 40.1 General..... 83
 40.2 Functional sequence 84
 40.3 Display information 85
 40.4 Monitoring integrity 85
 41 Common Performance and Monitoring for Integrity 86
 41.1 General Requirements for Common Performance and Monitoring for Integrity 86
 41.2 Initiating Device Circuits (IDC) 88
 41.3 Notification Appliance Circuits (NAC) 88
 41.4 Signaling line circuits 89
 41.5 Communication Link (CL)..... 89
 41.6 Low-Power Radio-Frequency Signaling..... 90
 42 Security and Data Protection 91
 42.1 General..... 91
 42.2 Communication Security 92
 42.3 Stored Data Security 92
 42.4 Access Control Security 93
 42.5 Physical Security 94
 42.6 Physical Security Attack Test 94
 42.7 Audit Control 95
 43 Trouble Signals 95
 44 Components – Monitoring for Integrity..... 96
 45 Software 98
 45.1 General..... 98
 45.2 User access and programming 99
 45.3 Software integrity 100
 46 Combination Systems with Non-Emergency, Security, Building Controls, and Other Non-Fire Equipment 101

PERFORMANCE – OTHER TESTS

47 General 104
 48 Power Input/Output Characteristics Tests 104
 49 Harmonic Distortion Test 104
 49.1 Crossover 104
 49.2 Total Harmonic 104
 50 Electrical Ratings Test 105
 50.1 General..... 105
 50.2 Power input circuits 105
 50.3 Other external circuits 105
 51 Variable Voltage Operation Test 105
 52 Class 2 and Class 3 Circuits Test 106
 52.1 General..... 106

	52.2 Maximum voltage	109
	52.3 Maximum current.....	109
	52.4 VA_{max} (not inherently limited circuits only)	109
53	Compatibility Tests	110
	53.1 General.....	110
	53.2 Notification appliance circuits (NAC).....	110
	53.4 Power output circuits.....	114
	53.5 Signaling line circuit (SLC).....	115
54	Component Temperature Test	115
55	Charging Current Test.....	119
	55.1 General.....	119
	55.2 Discharged battery.....	119
	55.3 Charged battery.....	120
	55.4 Discharged battery – second trial	120
56	Variable Ambient Temperature and Humidity Tests.....	121
	56.1 General.....	121
	56.2 Low temperature test	121
	56.3 High temperature test.....	122
	56.4 Humidity test	122
57	Overload Test.....	123
	57.1 Products supplied from commercial AC power systems	123
	57.2 Separately energized circuits.....	123
	57.3 Battery charger transfer mechanism.....	124
	57.4 Amplifiers.....	124
58	Endurance Test.....	124
	58.1 General.....	124
	58.2 Integral operating devices	125
	58.3 Power supplies.....	125
	58.4 Battery charger.....	125
	58.5 Audible signaling appliance	126
	58.6 Amplifiers.....	126
59	Jarring Test.....	126
60	Leakage Current Test	127
61	Transient Tests.....	130
	61.1 General.....	130
	61.2 Externally-induced supply-line transients	131
	61.3 Internally-induced transients	131
	61.4 Input/output (low-voltage) field-wiring transients	131
62	Electric Shock Current Test	137
63	Ignition Test Through Bottom-Panel Openings.....	140
64	Dielectric Voltage-Withstand Test	141
65	Abnormal Operation Tests.....	142
	65.1 General.....	142
	65.2 Operation.....	143
	65.3 Field-wiring circuits	143
	65.4 Electronic components.....	143
	65.5 Cooling fans and blowers	144
	65.6 Transformer burnout	145
	65.7 Communications circuits	145
	65.8 Evaluation of reduced spacings on printed-wiring boards	146
66	Tests on Special Terminal Assemblies.....	146
	66.1 General.....	146
	66.2 Mechanical secureness test	147
	66.3 Flexing test	147
	66.4 Millivolt drop test.....	147
	66.5 Temperature test	147

67	Mechanical Strength Test for Metal Enclosures and Guards and Enclosure Parts Secured with Adhesive.....	147
68	Radio Frequency Interference Test	150
69	Short-Range Radio Frequency (RF) Devices Test.....	150
	69.1 General.....	150
	69.2 Reference level determination	151
	69.3 Interference immunity	151
	69.4 Frequency selectivity	152
	69.5 Clash	152
	69.6 Clash error	153
	69.7 Error (falsing) rate.....	154
	69.8 Throughput rate.....	155
	69.9 Transmitter stability tests.....	156
	69.10 Transmitter accelerated aging test.....	156
70	Long-Range Radio Frequency (RF) Device Tests	156
	70.1 General.....	156
	70.2 Reference signal level.....	157
	70.3 Throughput rate test.....	157
	70.4 Error (falsing) rate test.....	158
	70.5 Adjacent channel rejection test	158
	70.6 Intermodulation rejection test.....	159
	70.7 Spurious response rejection test.....	159
	70.8 Clash.....	160
71	Primary Batteries Test.....	161
	71.1 Life test.....	161
	71.2 Battery trouble voltage determination	162
	71.3 Battery replacement test	164
	71.4 Butt-type connection pressure test.....	164
72	Strain-Relief Test.....	165
	72.1 Cord-connected products	165
	72.2 Field connection leads	165
73	Antenna End-Piece Secureness Test.....	165
74	Polarity Reversal Test.....	165
75	Wall, Ceiling, or Pole Mounting Test.....	166
76	Wet Location and Outdoor-Use Tests.....	166
	76.1 General.....	166
	76.2 Corrosion tests	166
	76.3 Dust test.....	167
	76.4 Water spray test	167
	76.5 Gasket testing	171
	76.6 Polymeric and adhesive materials tests	172

PERFORMANCE TESTS – HPSA

77	General	172
	77.1 HPSA Systems.....	172
	77.2 Integral control equipment and separate subsystems	173
78	HPSA Performance Tests	173
	78.1 Directivity Test.....	173
	78.2 HPSA System Performance	173
	78.3 Dielectric Breakdown Test	178
	78.4 Environmental Tests – Top of the Mast Subsystem (HPSAs and Solar Panels)	180
	78.5 Environmental Tests – Outdoor Control Subsystem.....	188
	78.6 Environmental Tests – Indoor Control Subsystem.....	194

MANUFACTURING AND PRODUCTION LINE TESTS

79	Dielectric Voltage-Withstand Test	195
80	Grounding-Continuity Test.....	196

MARKING AND INSTRUCTIONS

81	Markings.....	196
	81.1 General.....	196
	81.2 HPSA	199
	81.3 Permanence of marking	201
82	Installation Wiring Diagram/Instructions	201
83	Operating Instructions.....	206

Appendix A

	Standards for Components	207
--	--------------------------------	-----

ULNORM.COM : Click to view the full PDF of UL 2572 2024

INTRODUCTION

1 Scope

1.1 These requirements cover discrete electrical control units, communication units, transport products which manipulate the data packets, interfaces, and accessories for mass notification systems to be employed in accordance with the National Fire Alarm and Signaling Code, NFPA 72.

1.2 The products covered by this standard are intended to be used in combination with other appliances and devices to form an emergency communication and/or mass notification system. These products are intended to communicate critical information within buildings and/or outdoor areas about emergencies including but not limited to terrorist activities, hazardous chemical releases, severe weather, fire, and other situations that may endanger the safety of the occupants of an area or facility. Communication is through voice and visual instructions, as well as alert and evacuation signals. An installation document(s) provided with the product describes the various products needed to form an emergency communication and/or mass notification system and their intended use and installation.

1.3 These requirements address emergency service personnel communication system interfaces used in the performance of their duties if that communication equipment is used to interface with or control the ECS/MNS.

1.4 Audible notification appliances are to be assessed to the Standard for Audible Signaling Devices for Fire Alarm and Signaling Systems, Including Accessories, UL 464, and the Standard for Speakers for Fire Alarm and Signaling Systems, Including Accessories, UL 1480. Visible notification appliances are to be assessed to the Standard for Signaling Devices for the Hearing Impaired, UL 1971, or the Standard for Visible Signaling Devices for Fire Alarm and Signaling Systems, Including Accessories, UL 1638, as applicable. Textual visible appliances are to be assessed to the UL 1638.

1.5 Products incorporating fire and/or security signaling functions or other life safety systems shall comply with the UL standards applicable to their intended function and application in addition to this standard.

1.6 Non-fire emergency manual actuating stations shall comply with the requirements of the Standard for General Purpose Signaling Devices and Systems, UL 2017.

2 Components

2.1 Except as indicated in [2.2](#), a component of a product covered by this standard shall comply with the requirements for that component. See Appendix [A](#) for a list of standards covering components used in the products covered by this standard.

2.2 A component is not required to comply with a specific requirement that:

- a) Involves a feature or characteristic not required in the application of the component in the product covered by this standard, or
- b) Is superseded by a requirement in this standard.

2.3 A component shall be used in accordance with its rating established for the intended conditions of use.

2.4 Specific components are incomplete in construction features or restricted in performance capabilities. Such components are intended for use only under limited conditions, such as certain temperatures not exceeding specified limits, and shall be used only under those specific conditions.

3 Units of Measurement

3.1 Values stated without parentheses are the requirement. Values in parentheses are explanatory or approximate information.

4 Undated References

4.1 Any undated reference to a code or standard appearing in the requirements of this standard shall be interpreted as referring to the latest edition of that code or standard.

5 Glossary

5.1 For the purpose of this standard, the following definitions apply.

5.2 **ACKNOWLEDGE** – Action taken to confirm that a message or signal has been received, such as pressing a button.

5.3 **ADVERSE CONDITION** – Any condition occurring in a circuit or communication path that interferes with the proper signaling or interpretation of status-change signals or both. Conditions include radio frequency interference.

5.4 **AIR-HANDLING SPACE** – Space not specifically fabricated for environmental air-handling purposes but used for air handling purposes as a plenum. (The space above a hung ceiling used for environmental air-handling is an example.)

5.5 **ALARM SIGNAL** – A signal indicating an emergency condition requiring immediate action.

5.6 **ALERT TONE** – An attention-getting signal to alert occupants of the pending transmission of a voice message.

5.7 **ANCILLARY FUNCTION/DEVICE** – Non-emergency and/or non-fire devices for functions such as general paging, background music, or other non-emergency signals.

5.8 **ANECHOIC CHAMBER** – a room characterized by an unusually low degree of reverberation, simulating a free-field condition which is free from both internal and external acoustical interference.

5.9 **ANNUNCIATOR** – A unit containing one or more indicator lamps, alphanumeric displays, or other equivalent means in which each indication provides status information about a circuit, condition, or location.

5.10 **AUTONOMOUS CONTROL UNIT (ACU)** – The primary local control unit for an in-building mass notification system, which monitors and controls notification appliances for a protected premise or building.

5.11 **BUILDING** – Any structure used or intended for supporting or sheltering any use or occupancy. The term building is to be understood as if followed by the words or portions thereof¹⁾. Also, a building can be further delineated as a subdivision of a structure:

- a) Separate means of egress for the occupant load, but a minimum of two exits, and
- b) Separated from all other building divisions by a minimum 2-hour rated fire protection construction system.

1) The first two sentences of 5.11 originated from 3.3.32 and A.3.3.32 of the Life Safety Code® NFPA 101® - 2009, © 2009 NFPA; the remaining material is not that of the NFPA. Life Safety Code® & NFPA 101® are registered trademarks of the National Fire Protection Association, Quincy, MA.

5.12 CHANNEL – A path for voice or signal transmission utilizing modulation of light or alternating current within a frequency band.

5.13 CIRCUIT CLASSIFICATIONS:

a) High-Voltage Circuit – A circuit involving a potential of not more than 600 volts nominal and having characteristics in excess of those of a low-voltage circuit.

b) Low-Voltage Circuit – A circuit involving a potential of not more than 30 volts alternating current (AC) rms, 42.4 volts direct current (DC) or peak.

c) Power-Limited/Class 2/3 Circuit – A circuit wherein the power is limited as specified in [Table 52.1](#) and [Table 52.2](#).

5.14 COMBINATION SYSTEM – An emergency alarm system whose components might be used, in whole or in part, in common with a non-emergency alarm signaling system such as smoke control, security, non-critical process monitoring, paging, or building automation.

5.15 COMMUNICATION LINK (CL) – Supervised physical media or wireless methodology for providing a data connection and control circuits between a life safety system within a building and a Emergency Communications Control Unit and/or other control/annunciation systems on contiguous or non-contiguous property. Example – Ethernet data connection from a building on a campus and a management/safety facility that monitors and controls the building system.

5.16 CONTIGUOUS PROPERTY – A single owner or single user on a continuous plot of ground, including any buildings thereon, that is not separated by a public thoroughfare, transportation right-of-way, property owned or used by others, or body of water not under the same ownership.

5.17 CONTROL LOCATIONS – Consists of an authorized personnel operator interface such as a LOC, ACU, or ECCU that can obtain control of an audio network and the respective notification zones.

5.18 DIRECTIVITY – is the response (audibility) of a transducer as a function of the direction of the transmitted sound waves in a specified plane and at a specified frequency.

5.19 DISPLAY – The visual representation of output data or status information, other than printed copy.

5.20 DISTINCTIVE SIGNALS – Signals obtained from different sounding appliances (such as bells, horns, sirens, and buzzers) or from a single appliance (such as an electronic horn) where a continuous signal is obtained under one condition and a pulsing signal under another.

5.21 DISTRIBUTED RECIPIENT MASS NOTIFICATION SYSTEM – A system intended to communicate to targeted individuals that may not be in a contiguous area.

5.22 DISTRIBUTED RECIPIENT MASS NOTIFICATION SYSTEMS – HOSTED – A system hosted by a service provider intended to communicate to targeted individuals that may not be in a contiguous area.

5.23 DISTRIBUTED RECIPIENT MASS NOTIFICATION SYSTEMS – HYBRID – A system that can be a combination of both hosted and premise based.

5.24 DISTRIBUTED RECIPIENT MASS NOTIFICATION SYSTEMS – HYBRID-HOSTED – A system that can be a combination of both hosted and premise based. A system hosted by a service provider, with on-premise components connecting to local notification distribution capabilities and MNS components, such as fire alarms, digital displays, unified communication systems, etc. The on premise components of this system must comply with this standard.

5.25 DISTRIBUTED RECIPIENT MASS NOTIFICATION SYSTEMS – HYBRID-PREMISE-BASED – A system hosted within a customer's internal network, connecting to hosted notification distribution capabilities, such as text messaging, voice telephony, email, etc. The on premise components of this system must comply with this standard.

5.26 DISTRIBUTED RECIPIENT MASS NOTIFICATION SYSTEMS – PREMISED-BASED – A system hosted within a customer's internal network intended to communicate to targeted individuals that may or may not be in a contiguous area.

5.27 DUAL TONE MULTI FREQUENCY (DTMF) – Where specific tones are assigned to touch tone phones for signal detection across analog lines.

5.28 ECS/MNS – A configuration of components and interfaces that are used to communicate information to occupants in a building, area site, or other space about emergency conditions. Systems may consist of equipment that can reproduce live and recorded voice messages, tones and visual indicators such as strobe lights and visual displays.

5.29 EMERGENCY COMMUNICATIONS CONTROL UNIT (ECCU) – A system with ECS/MNS communications and control used in conjunction with one or more ACUs, local wide area, or wide area mass notification system applications.

5.30 EMERGENCY CONDITION – A sudden and/or unusual event that may impart harm to a being, operation, facility or similar entity that requires immediate action or response. Examples of an emergency event – terrorism, fire, security breach, inclement weather. Examples of a non-emergency event – sales updates, general paging, music.

5.31 EMERGENCY CONTROL FUNCTION – Building, fire, and emergency control functions that are intended to increase the level of life safety for occupants or to control the spread of the harmful effects of fire or other dangerous products.

5.32 EMERGENCY CONTROL FUNCTION INTERFACE DEVICE – A fire alarm or signaling system component that directly interfaces with the system that operates the emergency control function.

5.33 EMERGENCY CONTROL UNIT – A device that is used in the transmission of digital or analog data from the ACU, ECCU, and/or LOC to other building-systems control units, equipment, or networks, and/or from other building system control units to the emergency system.

5.34 EMERGENCY VOICE/ALARM COMMUNICATIONS – Dedicated manual or automatic facilities for originating and distributing voice instructions, as well as evacuation signals pertaining to an emergency, to the occupants of a building.

5.35 END-OF-LINE DEVICE – A device installed at the end of a circuit for the purpose of monitoring the circuit for fault conditions.

5.36 EVACUATION – The withdrawal of occupants from a building.

5.37 EVACUATION SIGNAL – Distinctive signal intended to be recognized by the occupants as requiring evacuation of the building.

- 5.38 EXTERNAL CIRCUITS – Circuits or wiring leaving the product.
- 5.39 FAULT – An open, ground, or short-circuit condition on any line extending from a product.
- 5.40 FIELD WIRING – Conductors connecting the product to source(s) of supply, devices, other products, and loads.
- 5.41 FIXED EQUIPMENT – Any equipment product that is intended to be permanently connected electrically to the wiring system.
- 5.42 GATEWAY – A device that is used in the transmission of digital or analog data from the emergency control unit to other building-systems control units, equipment, or networks, and/or from other building system control units to the emergency system.
- 5.43 GROUND FAULT – A circuit impedance to ground sufficient to result in the annunciation of a trouble condition.
- 5.44 GROUNDED CONDUCTOR – A conductor employed to connect the intentionally grounded circuit of a wiring system to a grounding electrode.
- 5.45 GROUNDING CONDUCTOR – A conductor employed to connect non-current-carrying parts of equipment, raceways, and enclosure to a grounding electrode at the service which is, in turn, connected to earth ground or to some conducting body which serves in place of earth ground.
- 5.46 HIGH POWER SPEAKER ARRAY (HPSA) – A product providing capability for voice and tone communication to large outdoor areas.
- 5.47 IN-BUILDING MASS NOTIFICATION SYSTEM – A system used to provide information and instructions to occupants in a building or other space using voice communication, visible signaling and other communication methods.
- 5.48 INITIATING DEVICE – A manually or automatically operated device, the normal intended operation of which results in signal indication from the product/system.
- 5.49 INITIATING DEVICE CIRCUIT – Circuit to which automatic or manual initiating devices are connected where the signal received does not identify the individual device operated. Examples include: Biological detectors, tornado alert, panic switch, dry relay contact from other emergency product or fire alarm control unit.
- 5.50 INITIATING ZONE – A defined area within the protected premises that contains one or more Initiating Devices, for which a status indication can be received.
- 5.51 INSTALLATION LOCATIONS:
- a) Damp – A location protected from sun, rain, and water, but may be subject to moisture. Such locations may include basements, barns, cold-storage warehouses, greenhouses, indoor swimming facilities, and the like. They may also include partially protected locations under canopies, marquees, roofed open porches, and the like.
 - b) Dry – A location with a controlled ambient that is not subject to dampness or wetness.
 - c) Wet – A location subject to rain (or the spray of noncorrosive and nonflammable liquids) that may become saturated with water or that is unprotected from the weather. Includes locations underground, or in concrete slabs or masonry in direct contact with the earth.

5.52 LIFE SAFETY NETWORK – A type of combination system that transmits life safety data through gateways to other life safety systems.

5.53 LOCAL OPERATING CONSOLE (LOC) – An in-building mass notification system operating console for authorized occupants to initiate messages and signaling in an emergency condition.

5.54 LONG-RANGE RADIO-FREQUENCY DEVICES – Any device that communicates between a protected premises and a subsidiary station, supervising station, or another protected premises using a private radio network.

5.55 MESSAGE(S) – Communicated data that contains specific information relating to the status of the product and is transmitted via a wired or wireless pathway from an origin to a destination.

5.56 NON-CONTIGUOUS PROPERTY – A series of plots of land under the same ownership including any buildings thereon that are separated by a public thoroughfare, transportation right-of-way, property owned by a party or used by others.

5.57 NON-EMERGENCY FUNCTION – A function not associated with property protection and/or life safety.

5.58 NON-VOLATILE MEMORY – A storage device not alterable by the interruption of the power to the memory; for example, ROM, FLASH, PROM, EPROM, and EEPROM.

5.59 NOTIFICATION APPLIANCE – A component that provides audible, tactile, or visible outputs or any combination thereof.

5.60 NOTIFICATION APPLIANCE CIRCUIT – A circuit or path directly connected to a notification appliance(s)³⁾. Examples include circuits that connect to non-addressable speakers, strobe lights, horns, chimes and other indicating appliances.

³⁾ The first sentence of 5.60 originated from 3.3.114 of the 2007 edition of the National Fire Alarm Code®, NFPA 72® - 2007, © 2007 NFPA; the remaining material is not that of the NFPA.

5.61 NOTIFICATION ZONE – An area covered by notification appliances that are activated simultaneously.

5.62 OPEN FAULT – A circuit impedance increase sufficient to prevent normal operation.

5.63 OPERATOR INTERFACE – Also referred to as a User Interface. The man-machine display and/or control point of a system that provides information as to system status and may provide system input or action capabilities so that the human operator may invoke commands and/or requests for information to the system. Systems may have one or more Operator Interfaces. This interface may be, but are not limited to a Graphical User Interface (GUI) such as a computer screen, a Liquid Crystal Display (LCD), Light Emitting Diodes (LED) or other luminary indicators and/or audible indicators and/or tactile displays.

5.64 PATH (PATHWAY) – Any conductor, optic fiber, radio carrier, or other means for transmitting information between two or more units and/or locations.

5.65 PORT – A physical interface on a product used for communications via a CL.

5.66 PORTABLE EQUIPMENT – A product that is easily carried or conveyed by hand. When intended to be connected to a high-voltage circuit, the product is provided with a power supply cord for connection to the supply circuit.

5.67 POWER SUPPLY – A source of electrical operating power including the circuits and terminations connecting it to the dependent product/system components.

5.68 PRERECORDED MESSAGE DEVICE – An automatically- or manually-actuated device intended to translate a pre-recorded message stored on a tape or other medium into an electronic signal that when amplified and introduced into speakers produces vocal or tonal information.

5.69 PRIMARY BATTERY – Any battery which by design or construction is not intended to be recharged.

5.70 PROTECTED PREMISES – The physical location protected by a fire alarm system⁴⁾.

⁴⁾ 5.70 originated from 3.3.142 of the 2007 edition of the National Fire Alarm Code®, NFPA 72® - 2007, © 2007 NFPA

5.71 QOS – Quality of Service refers to the ability to prioritize data of one particular type over another on a shared network.

5.72 REPEATER – Equipment used to relay signals between a remote unit, initiating device or similar device and the receiving unit.

5.73 RESET – A control function that attempts to return a system or device to its normal non-emergency state.

5.74 RISK OF ELECTRIC SHOCK – A risk of electric shock is determined to exist at any part if:

- a) The potential between the part and earth ground or any other accessible part is more than 42.4 V peak, and
- b) The continuous current flow through a 1500 ohm resistor connected across the potential exceeds 0.5 mA.

5.75 RISK OF FIRE – A risk of fire is considered to exist at any two points in a circuit where:

- a) The open circuit voltage is more than 42.4 V peak and the energy available to the circuit under any condition of load including short circuit, results in a current of 8 A or more after 1 minute of operation; or
- b) A power of more than 15 watts can be delivered into an external resistor connected between the two points.

5.76 SECONDARY POWER SOURCE – Provides power when the primary power source fails.

5.77 SHORT MESSAGE SERVICE (SMS) – A communication service using standardized communications protocols allowing the interchange of short text messages to and between mobile telephone devices. A SMS message can handle up to 160 characters including spaces.

5.78 SIGNALING-LINE CIRCUIT (SLC) – A physical media circuit path between any combination of addressable appliances or devices, circuit interfaces, control units, or transmitters over which multiple input signals output signals or both are carried. Examples – Addressable input/output device circuits, circuits to data devices such as printers.

5.79 SOFTWARE – Programs, instructions, procedures, data, and the like that are executed by a central processing unit of a product and which influences the functional performance of that product. Composed of executive software and site-specific programming.:

- a) Executive Software – Control and supervisory program which manages the execution of all other programs and directly or indirectly causes the required functions of the product to be performed.
- b) Site-Specific Programming – Program that is separate from, but controlled by, the executive software which allows inputs, outputs, and system configuration to be selectively defined to meet the needs of a specific installation.
- 5.80 STATIONARY EQUIPMENT – Any product that is intended to be fastened in place or located in a dedicated space, and is provided with a power-supply cord for connection to the supply circuit.
- 5.81 STIPA TEST SIGNAL – A special audio signal that consists of signals in seven octave bands and which each octave band is modulated using two separate modulation frequencies that is played over the emergency communications system being tested. STIPA is standardized in IEC 60268.
- 5.82 STORAGE BATTERY – Any battery which, by design or construction, is intended to be recharged.
- 5.83 SUPERVISING STATION – The operator interface system to which alarm and trouble signals are directly monitored or are received from remote monitoring units. Intended to be constantly attended and maintained by competent and experienced personnel.
- 5.84 SUPERVISORY SIGNAL – A signal indicating the need for action in connection with opening of enclosure doors, tamper signals, or maintenance features of related systems.
- 5.85 SUPPLEMENTARY – Refers to equipment or operations not required by this standard.
- 5.86 SUPPLEMENTARY CIRCUIT OR PATHWAY – A circuit or pathway provided by a product for controlling a device, the operation of which is supplementary to the requirements of this standard.
- 5.87 SUPPLEMENTARY DEVICE – A device that has not been investigated to this standard intended to be connected to a supplementary device circuit.
- 5.88 TONE GENERATOR – A device intended to generate an electronic signal that, when amplified and introduced into speakers, produces a non-prerecorded, non-vocal, audible signal.
- 5.89 TRANSPONDER – A multiplex alarm transmission system functional assembly located remote from the supervising station.
- 5.90 TROUBLE SIGNAL – A visual or audible signal indicating a fault condition of any nature, such as a circuit break or ground or other trouble condition occurring in the device or wiring associated with a protective signaling system.
- 5.91 USER – An individual who operates or services the product.
- 5.92 WIDE AREA MASS NOTIFICATION SYSTEM – A system which provides real time information to areas, including outdoor, in a contiguous or non-contiguous campus, region or global geographical setting.
- 5.93 WIRE-TO-WIRE FAULT – A wire-to-wire (short circuit) fault is determined to be a resistance of 0.1 ohm or less across the circuit.
- 5.94 ZONE – A defined area within the protected premises. A zone defines an area from which a status indication can be received or an area in which a form of control can be executed.

CONSTRUCTION

6 General

6.1 A product shall use materials that have been determined to comply with the requirements for the particular use, as indicated by the performance requirements of this standard.

6.2 Metals, when required to meet the requirements of this standard, shall not be used in such combination as to cause galvanic action that will increase the risk of fire, electric shock, injury to persons, or impair the operation of a product associated with the safety of life and/or property protection.

6.3 Where breakage or deterioration of a part such as an enclosure, a frame, a guard, or the like can result in a risk of injury to persons, the part shall be constructed to meet the demand or expected loading conditions.

6.4 The requirement in [6.3](#) applies also to those positions of a part adjacent to a moving part identified to involve a risk of injury to persons.

6.5 Electrical equipment with nonmetallic enclosures and other non-metallic discrete objects, intended to be installed in air-handling spaces shall additionally comply with the requirements in the Standard for Fire Test for Heat and Visible Smoke Release for Discrete Products and Their Accessories Installed in Air-Handling Spaces, UL 2043.

6.5.1 Enclosure parts fastened with adhesive meeting [10.6](#) – [10.9](#) shall comply with the test requirements in Mechanical Strength Tests for Metal Enclosures and Guards and Enclosure Parts Fastened with Adhesive, Section [67](#).

6.6 Products that currently meet the requirements of UL 60950-1 or UL 60065 need only be evaluated to the following sections with respect to the construction requirements: [7.1](#), [10.5](#), [12.1](#), [12.2](#), [13.1](#) – [13.3](#), [13.6](#), [15.4](#), [20](#), [24.1](#), [26.3](#), and [28](#).

7 Enclosures

7.1 General

7.1.1 All electrical parts of a product shall be enclosed to provide protection of internal components and prevent contact with uninsulated live parts.

7.2 Metallic material

7.2.1 An enclosure of metal shall have a minimum thickness as specified in [Table 7.1](#), [Table 7.2](#), or [Table 7.3](#), or shall comply with the test requirements in Mechanical Strength Tests for Metal Enclosures and Guards, Section [67](#).

Table 7.1
Cast-metal electrical enclosures

Use, or dimensions of area involved ^a	Minimum thickness			
	Die-cast metal,		Cast metal other than die-cast,	
	inch	(mm)	inch	(mm)
Area of 24 square inches (155 cm ²) or less and having no dimension greater than 6 inches (152 mm)	1/16	(1.6)	1/8	(3.2)
Area greater than 24 square inches (155 cm ²) or having any dimension greater than 6 inches (152 mm)	3/32	(2.4)	1/8	(3.2)
At a threaded conduit hole	1/4	(6.4)	1/4	(6.4)
At an unthreaded conduit hole	1/8	(3.2)	1/8	(3.2)

^a The area limitation for metal 1/16 inch (1.6 mm) thick may be obtained by the provision of reinforcing ribs subdividing a larger area.

Table 7.2
Minimum thickness of sheet metal for electrical enclosures of carbon or stainless steel

Without supporting frame ^a		With supporting frame or equivalent reinforcing ^a		Minimum thickness					
Maximum width, ^b		Maximum length, ^c		Uncoated,		Metal coated,			
inches	(cm)	inches	(cm)	inches	(mm)	inches	(mm)		
				[MSG]	[GSG]				
4.0	(10.2)	Not limited	6.25	(15.9)	Not limited	0.020	(0.51)	0.023	(0.58)
4.75	(12.1)	5.75	(14.6)	6.75	(17.1)	8.25	(21.0)	[24]	[24]
6.0	(15.2)	Not limited	9.5	(24.1)	Not limited	0.026	(0.66)	0.029	(0.74)
7.0	(17.8)	8.75	(22.2)	10.0	(25.4)	12.5	(31.8)	[22]	[22]
8.0	(20.3)	Not limited	12.0	(30.5)	Not limited	0.032	(0.81)	0.034	(0.86)
9.0	(22.9)	11.5	(29.2)	13.0	(33.0)	16.0	(40.6)	[20]	[20]
12.5	(31.8)	Not limited	19.5	(49.5)	Not limited	0.042	(1.07)	0.045	(1.14)
14.0	(35.6)	18.0	(45.7)	21.0	(53.3)	25.0	(63.5)	[18]	[18]
18.0	(45.7)	Not limited	27.0	(68.6)	Not limited	0.053	(1.35)	0.056	(1.42)
20.0	(50.8)	25.0	(63.5)	29.0	(73.7)	36.0	(91.4)	[16]	[16]
22.0	(55.9)	Not limited	33.0	(83.8)	Not limited	0.060	(1.52)	0.063	(1.60)
25.0	(63.5)	31.0	(78.7)	35.0	(88.9)	43.0	(109.2)	[15]	[15]
25.0	(63.5)	Not limited	39.0	(99.1)	Not limited	0.067	(1.70)	0.070	(1.78)
29.0	(73.7)	36.0	(91.4)	41.0	(104.1)	51.0	(129.5)	[14]	[14]
33.0	(83.8)	Not limited	51.0	(129.5)	Not limited	0.080	(2.03)	0.084	(2.13)
38.0	(96.5)	47.0	(119.4)	54.0	(137.2)	66.0	(167.6)	[13]	[13]
42.0	(106.7)	Not limited	64.0	(162.6)	Not limited	0.093	(2.36)	0.097	(2.46)
47.0	(119.4)	59.0	(149.9)	68.0	(172.7)	84.0	(213.4)	[12]	[12]
52.0	(132.1)	Not limited	80.0	(203.2)	Not limited	0.108	(2.74)	0.111	(2.82)
60.0	(152.4)	74.0	(188.0)	84.0	(213.4)	103.0	(261.6)	[11]	[11]
63.0	(160.0)	Not limited	97.0	(246.4)	Not limited	0.123	(3.12)	0.126	(3.20)
73.0	(185.4)	90.0	(228.6)	103.0	(261.6)	127.0	(322.6)	[10]	[10]

Table 7.2 Continued on Next Page

Table 7.2 Continued

Without supporting frame ^a		With supporting frame or equivalent reinforcing ^a		Minimum thickness	
Maximum width, ^b		Maximum length, ^c		Uncoated,	
inches	(cm)	inches	(cm)	inches	(mm)
				[MSG]	[GSG]
<p>^a A supporting frame is a structure of angle or channel or a folded rigid section of sheet metal that is rigidly attached to and has essentially the same outside dimensions as the enclosure surface and that has sufficient torsional rigidity to resist the bending moments which may be applied via the enclosure surface when it is deflected. Construction that is considered to have equivalent reinforcing may be accomplished by designs that will produce a structure that is as rigid as one built with a frame of angles or channels. Construction considered to be without supporting frame includes:</p> <ol style="list-style-type: none"> 1) A single sheet with single formed flanges (formed edges), 2) A single sheet which is corrugated or ribbed, and 3) An enclosure surface loosely attached to a frame, for example, with spring clips. <p>^b The width is the smaller dimension of a rectangular sheet metal piece which is part of an enclosure. Adjacent surfaces of an enclosure may have supports in common and be made of a single sheet.</p> <p>^c For panels which are not supported along one side, for example, side panels of boxes, the length of the unsupported side shall be limited to the dimensions specified unless the side in question is provided with a flange at least 1/2 inch (12.7 mm) wide.</p>					

Table 7.3
Minimum thickness of sheet metal for electrical enclosures of aluminum, copper, or brass

Without supporting frame ^a		With supporting frame or equivalent reinforcing ^a		Minimum thickness,	
Maximum width, ^b		Maximum length, ^c		inches	
inches	(cm)	inches	(cm)	inches	(mm)
3.0	(7.6)	Not limited	7.0 (17.8)	Not limited	
3.5	(8.9)	4.0 (10.2)	8.5 (21.6)	9.5 (24.1)	0.023 (0.58)
4.0	(10.2)	Not limited	10.0 (25.4)	Not limited	
5.0	(12.7)	6.0 (15.2)	10.5 (26.7)	13.5 (34.3)	0.029 (0.74)
6.0	(15.2)	Not limited	14.0 (35.6)	Not limited	
6.5	(16.5)	8.0 (20.3)	15.0 (38.1)	18.0 (45.7)	0.036 (0.91)
8.0	(20.3)	Not limited	19.0 (48.3)	Not limited	
9.5	(24.1)	11.5 (29.2)	21.0 (53.3)	25.0 (63.5)	0.045 (1.14)
12.0	(30.5)	Not limited	28.0 (71.1)	Not limited	
14.0	(35.6)	16.0 (40.6)	30.0 (76.2)	37.0 (94.0)	0.058 (1.47)
18.0	(45.7)	Not limited	42.0 (106.7)	Not limited	
20.0	(50.8)	25.0 (63.5)	45.0 (114.3)	55.0 (139.7)	0.075 (1.91)
25.0	(63.5)	Not limited	60.0 (152.4)	Not limited	
29.0	(73.7)	36.0 (91.4)	64.0 (162.6)	78.0 (198.1)	0.095 (2.41)
37.0	(94.0)	Not limited	87.0 (221.0)	Not limited	
42.0	(106.7)	53.0 (134.6)	93.0 (236.2)	114.0 (289.6)	0.122 (3.10)
52.0	(132.1)	Not limited	123.0 (312.4)	Not limited	
60.0	(152.4)	74.0 (188.0)	130.0 (330.2)	160.0 (406.4)	0.153 (3.89)

^a A supporting frame is a structure of angle or channel or a folded rigid section of sheet metal which is rigidly attached to and has essentially the same outside dimensions as the enclosure surface and which has sufficient torsional rigidity to resist the bending

Table 7.3 Continued on Next Page

Table 7.3 Continued

Without supporting frame ^a		With supporting frame or equivalent reinforcing ^a		Minimum thickness, inches (mm)
Maximum width, ^b inches (cm)	Maximum length, ^c inches (cm)	Maximum width, ^b inches (cm)	Maximum length, inches (cm)	
<p>moments which may be applied via the enclosure surface when it is deflected. Construction that is considered to have equivalent reinforcing may be accomplished by designs that will produce a structure which is as rigid as one built with a frame of angles or channels. Construction considered to be without supporting frame includes:</p> <ol style="list-style-type: none"> 1) A single sheet with single formed flanges (formed edges), 2) A single sheet which is corrugated or ribbed, and 3) An enclosure surface loosely attached to a frame, for example, with spring clips. <p>^b The width is the smaller dimension of a rectangular sheet metal piece which is part of an enclosure. Adjacent surfaces of an enclosure may have supports in common and be made of a single sheet.</p> <p>^c For panels which are not supported along one side, for example, side panels of boxes, the length of the unsupported side shall be limited to the dimensions specified unless the side in question is provided with a flange at least 1/2 inch (12.7 mm) wide.</p>				

7.2.2 Where threads for the connection of conduit are tapped all the way through a hole in an enclosure wall, or where a construction that is determined to be equivalent is used, there shall not be less than 3-1/2 nor more than 5 threads in the metal, and the construction shall be such that a standard conduit bushing can be attached.

7.2.3 Where threads for the connection of conduit are tapped only part of the way through a hole in an enclosure wall, there shall not be less than five full threads in the metal, and there shall be a smooth, rounded inlet hole for the conductors which shall afford protection to the conductors equivalent to that provided by a standard conduit bushing.

7.2.4 At any point where conduit or metal-clad cable is to be attached to the enclosure, sheet metal shall be of such thickness or shall be so formed or reinforced that it will have stiffness at least equivalent to that of an uncoated flat sheet of steel having a minimum thickness of 0.032 inch (0.81 mm).

7.3 Polymeric materials

7.3.1 Polymeric materials used as an enclosure shall comply with the applicable portion of the Standard for Polymeric Materials – Use in Electrical Equipment Evaluations, UL 746C, and also with the additional requirements specified in this standard.

7.3.2 Polymeric material that is not used as an enclosure, but that is attached to or exposed on the outside of a product such as a viewing window, shall have flammability characteristics as shown in [Table 7.4](#).

Table 7.4
Flammability characteristics of polymeric material

Polymeric material area/dimensions	Flammability rating
0.24 inches ³ (4 cm ³) maximum and 2.4 inches (61 mm) maximum length	None
Greater than 0.24 inches ³ (4 cm ³) and less than 2 square feet (0.19 m ²), 6 feet (1.83 m) maximum length	HB, V-2, V-1, V-0, or 5V

Table 7.4 Continued on Next Page

Table 7.4 Continued

Polymeric material area/dimensions	Flammability rating
Greater than 2 square feet (0.19 m ²) and less than 10 square feet (0.93 m ²), 6 feet (1.83 m) maximum length	V-1, V-0, or 5V
Greater than 10 square feet (0.93 m ²), or longer than 6 feet (1.83 m)	Maximum flame spread rating of 200 as specified in the Standard for Test for Surface Burning Characteristics of Building Materials, UL 723, or radiant panel as specified in the Standard for Tests for Flammability of Plastic Materials for Parts in Devices and Appliances, UL 94

7.3.3 Conductive coatings applied to nonmetallic surfaces such as the inside surface of an enclosure, shall comply with the appropriate requirements in the Standard for Polymeric Materials – Use in Electrical Equipment Evaluations, UL 746C, unless flaking or peeling of the coating cannot result in the reduction of spacings or the bridging of live parts.

7.3.4 A polymeric enclosure intended for connection to a rigid metallic conduit system shall comply with the requirements for polymeric enclosure rigid metallic conduit connections in the Standard for Enclosures for Electrical Equipment, Non-Environmental Considerations, UL 50.

7.3.5 The continuity of a conduit system shall be provided by metal-to-metal contact and not rely on a polymeric material and shall comply with the requirements for polymeric enclosure bonding in the Standard for Enclosures for Electrical Equipment, Non-Environmental Considerations, UL 50.

7.4 Covers

7.4.1 An enclosure cover shall be hinged, sliding, pivoted or similarly attached to provide access to fuses or any other over current-protective device, the intended protective functioning of which requires renewal or resetting, or when it is necessary to open the cover in connection with the normal operation of the unit.

Exception: In lieu of providing a hinged, sliding, or pivoted cover, supervision of the enclosure cover by means of a tamper feature is suitable when its operation results in either a trouble or alarm signal. This applies only when the cover provides access to overcurrent devices such as fuses or circuit breakers or other indicators that are not used on a continuing basis.

7.4.2 Normal operation referenced in 7.4.1 is determined to be operation of a switch for testing or for silencing an audible signal appliance or operation of any other component of a unit which requires such action in connection with its intended performance.

7.4.3 A hinged cover is not required when the only fuse(s) enclosed is intended to provide protection to portions of internal circuits used on a separate printed-wiring board or circuit subassembly, to prevent circuit damage resulting from a fault. The use of such a fuse(s) is suitable when the following (or other wording that has been determined to be equivalent) is indicated as a marking on the outside of the cover: "Circuit Fuse(s) Inside – Disconnect Power Prior To Servicing."

7.4.4 Glass covering an observation opening shall be tempered and secured in place so that it cannot be displaced and shall provide mechanical protection for the enclosed parts. The thickness of a glass cover shall not be less than that indicated in [Table 7.5](#).

Table 7.5
Thickness of glass covers

Maximum size of opening				Minimum thickness,	
Length or width,		Area,			
inches	(mm)	inches ²	(cm ²)	inch	(mm)
4	(102)	16	(103)	1/16	(1.6)
12	(305)	144	(929)	1/8	(3.2)
over 12	(over 305)	over 144	(over 929)	see note a	

^a 1/8 inch (3.2 mm) or more, depending upon the size, shape, and mounting of the glass panel.

7.4.5 A glass panel for an opening having an area of more than 144 square inches (929 cm²), or having any dimension greater than 12 inches (305 mm), shall be supported by a continuous groove not less than 3/16 inch (4.8 mm) deep along all four edges of the panel, or other means that have been determined to be an equivalent arrangement.

7.4.6 A transparent material other than glass used for the cover of an observation opening shall not introduce a risk of fire, distort, nor become less transparent at the temperature to which it is intended to be subjected under either normal or abnormal service conditions. See [7.3.2](#).

7.5 Battery compartments

7.5.1 A compartment for vented storage batteries shall have a total volume at least twice the volume occupied by the batteries. Ventilating openings shall be provided and so located as to permit circulation of air for dispersion of gas while the battery is being charged at the highest rate permitted by the means incorporated in the control unit.

7.5.2 The interior of a storage battery compartment shall be protected so that it will be resistant to detrimental action by the electrolyte.

7.6 Enclosure openings – General

7.6.1 An enclosure intended for recessed mounting and whose front panel is to be flush with the surface of the wall shall have no openings that vent into concealed spaces of a building structure, such as into hollow spaces in the wall, when the product is mounted as intended.

Exception: Products supplied solely from Class 2 or 3 sources and controlling only Class 2 or 3 loads.

7.6.2 The requirement in [7.6.1](#) does not apply to an opening for a mounting screw or nail or for a manufacturing operation (such as paint drainage) when:

- a) An opening for non-mounting purposes does not have a dimension greater than 17/64 inch (6.75 mm) or an area greater than 0.055 square inch (35.5 mm²) and
- b) An opening for mounting does not have a dimension greater than 0.75 inches (19.05 mm) or an area greater than 0.7 inches² (430 mm²) and there are no more holes than are needed to mount the product.

7.7 Enclosure top openings

7.7.1 An opening directly over an uninsulated live part involving a risk of fire, electric shock, or electrical-energy/high-current levels, shall not exceed 0.20 inch (5.0 mm) in any dimension unless the configuration

is such that a vertically falling object cannot fall into the unit and contact an uninsulated live part. See [Figure 7.1](#) for examples of top-cover designs complying with the intent of the requirement.

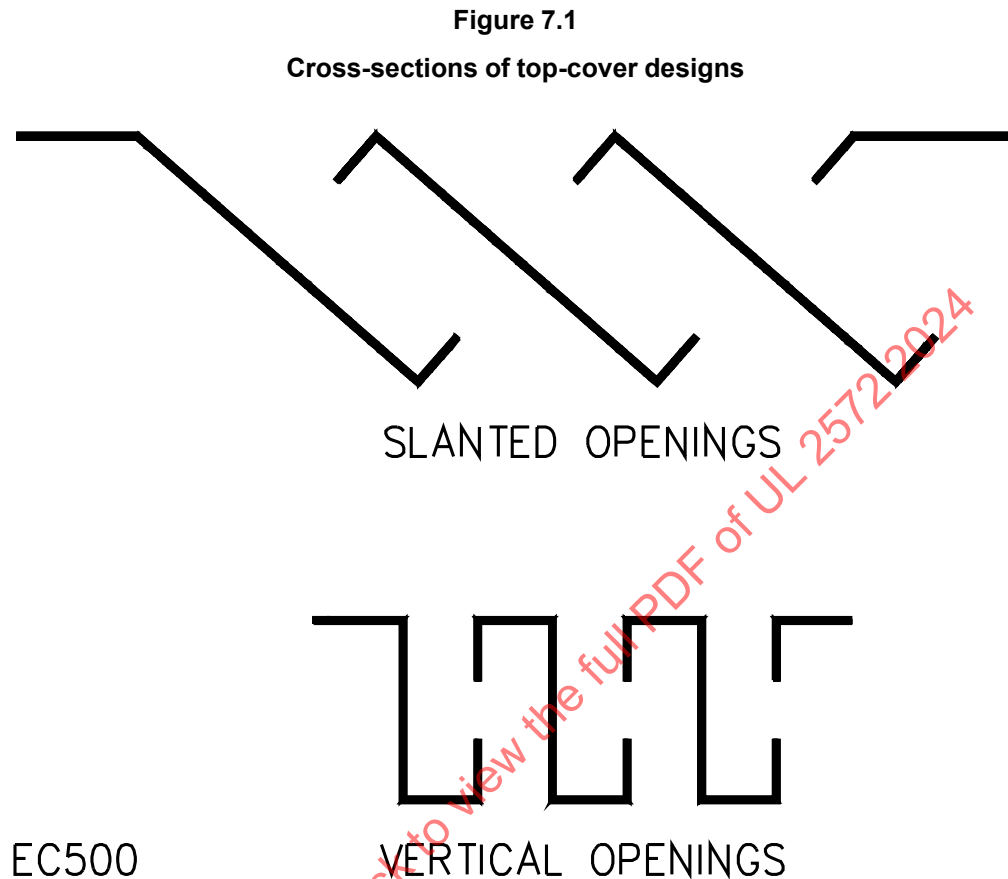

7.8 Enclosure side openings

7.8.1 An opening in the side of the enclosure shall:

- a) Not exceed 0.19 inch (4.8 mm) in any dimension;
- b) Be provided with louvers shaped to deflect an external falling object outward (see [Figure 7.2](#) for examples of louver designs complying with the requirement); or
- c) Be located and sized so that objects which are present cannot drop into the unit and fall (with no horizontal velocity) onto uninsulated live parts involving a risk of fire, electric shock, or electrical-energy/high-current levels, or parts involving injury to persons (see [Figure 7.3](#)).

Figure 7.2
Louvers

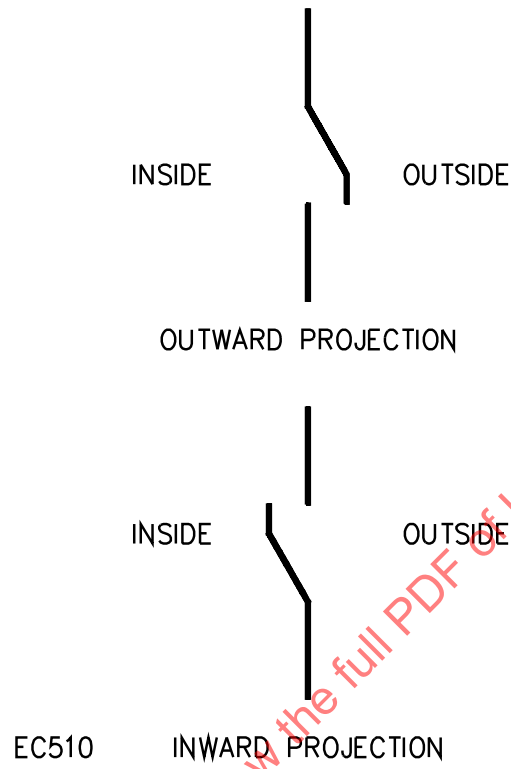

ULNORM.COM : Click to view the full PDF of UL 2572 2024

Figure 7.3
Example of enclosure side opening

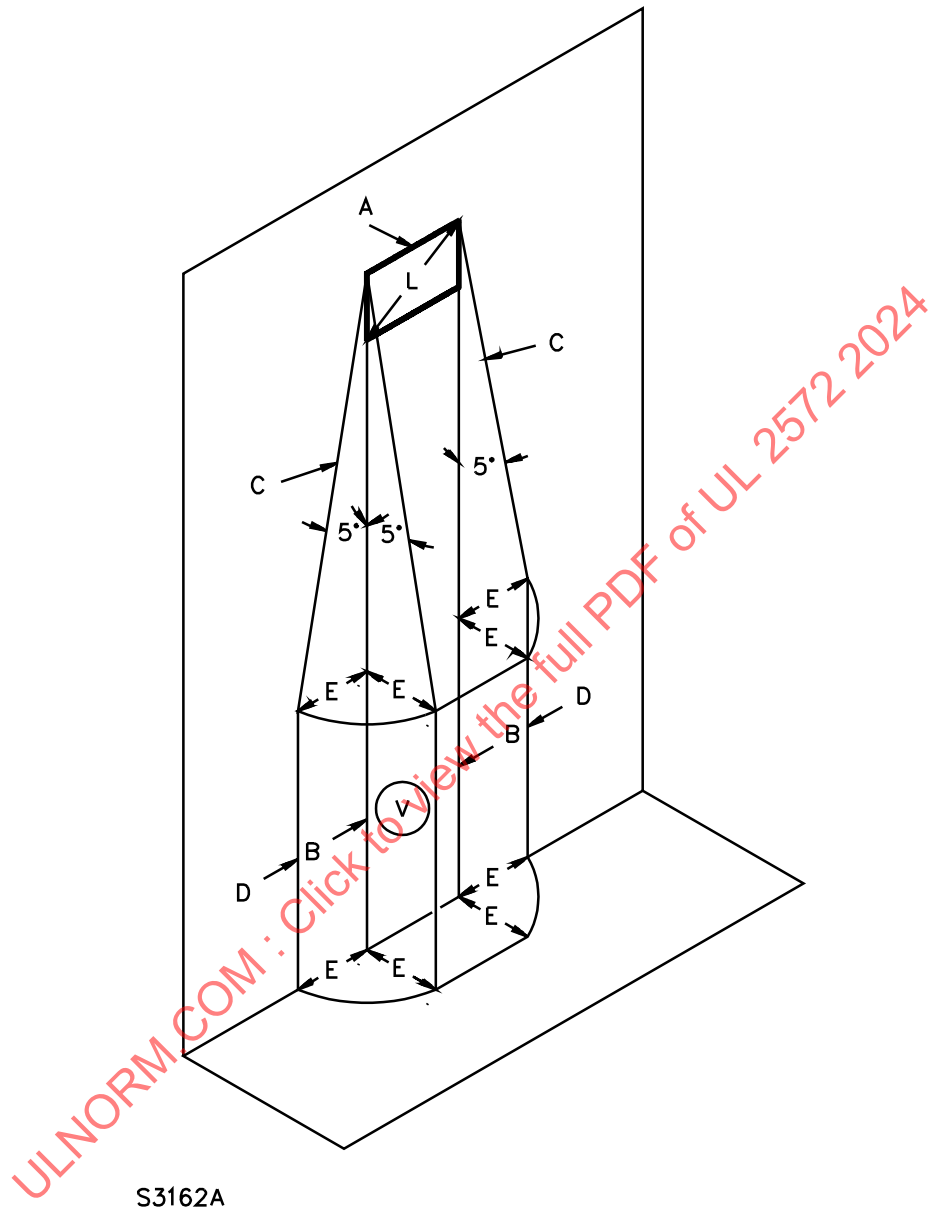

S3162A

- A – Enclosure side opening.
- B – Vertical projection of the outer edges of the side opening.
- C – Inclined lines that project at a 5-degree angle from the edges of the side opening to point located E distance from B.
- D – Line which is projected straight downward in the same plane as the enclosure side wall.
- E – Projection of the opening (not to be greater than L).
- L – Maximum dimension of the enclosure side opening.
- V – Volume in which bare parts at uninsulated live parts are not located.

7.8.2 When a portion of a side panel falls within the area traced out by the 5-degree angle in [Figure 7.4](#), that portion of the side panel shall be investigated as a bottom enclosure in accordance with [7.9.1](#) – [7.9.3](#).

ULNORM.COM : Click to view the full PDF of UL 2572 2024

Figure 7.4
Enclosure bottom

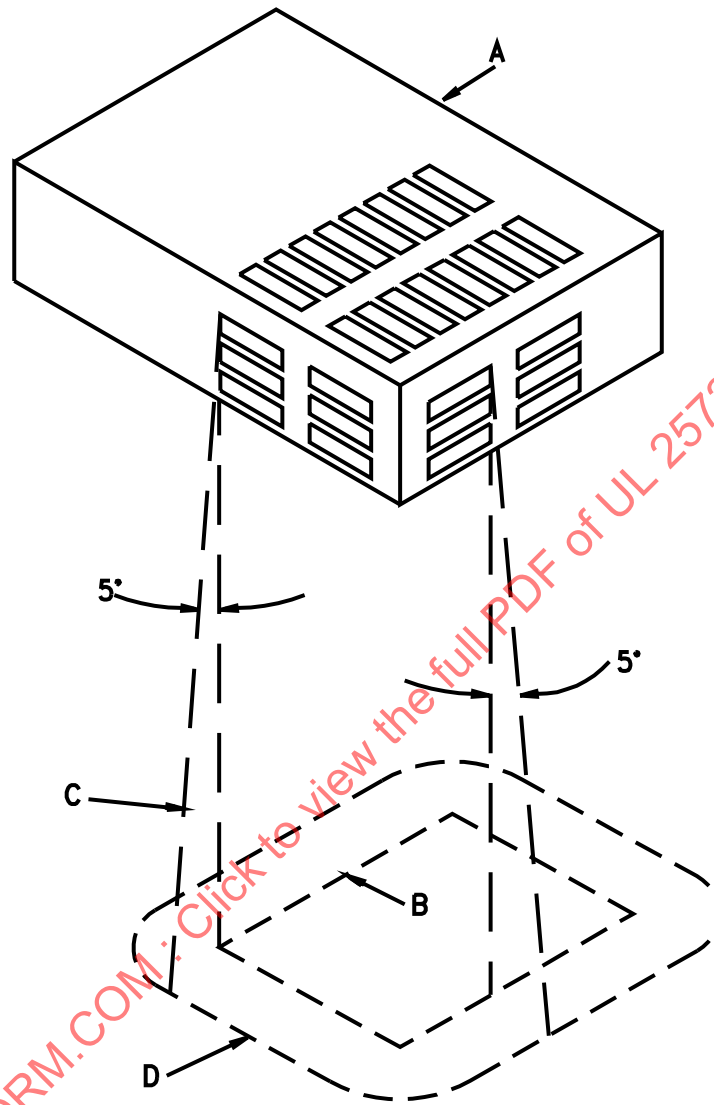

S2600

A – The entire component under which an enclosure (flat or dished with or without a lip or other raised edge) of noncombustible material is to be provided. The sketch is of an enclosed component with ventilation openings showing that the enclosure is required only for those openings through which flaming parts are to be emitted. When the component or assembly does not have its own noncombustible enclosure, the area to be protected is the entire area occupied by the component or assembly.

B – Projection of the outline of the area of A that requires a bottom enclosure vertically downward onto the horizontal plane of the lowest point on the outer edge D of the enclosure.

C – Inclined line that traces out an area D on the horizontal plane of the enclosure. Moving around the perimeter of the area B that requires a bottom enclosure, this line projects at a 5 degree angle from the line extending vertically at every point around the perimeter of A and is oriented to trace out the largest area; except that the angle shall be less than 5 degrees when the enclosure bottom contacts a vertical enclosure or side panel, or when the horizontal extension of the enclosure B to D exceeds 6 inches (152 mm).

D – Minimum outline of the enclosure, except that the extension B to D is not required to exceed 6 inches (152 mm), flat or dished with or without a tip or other raised edge. The bottom shall either be flat or formed in any manner when every point of area D is at or below the lowest point on the outer edge of the enclosure.

7.9 Enclosure bottom openings

7.9.1 The bottom of an enclosure shall consist of a complete or partial bottom enclosure under a component, groups of components, or assemblies, as shown in [Figure 7.4](#), that complies with the ventilation opening requirements in [7.9.2](#) and [7.9.3](#) unless a test demonstrates that the bottom enclosure provided contains flames, glowing particles or similar burning debris when all combustible material in the interior is ignited.

Exception: Openings without limitation on their size and number are permitted in areas that contain only wires, cables, plugs, receptacles, and impedance- and thermally-protected motors.

7.9.2 Ventilation openings provided in the bottom of an enclosure under materials that are not rated V-1 or less flammable meet the intent of the requirements when the openings are constructed so that materials do not fall directly from the interior of the unit. Other bottom-opening constructions that comply with the intent of the requirements are those that incorporate a perforated metal plate as described in [Table 7.6](#), or a galvanized or stainless-steel screen having a 14 by 14 mesh per 1 inch (25.4 mm) constructed of wire with a minimum diameter of 1/64 inch (0.4 mm). Other constructions are to be used only when they comply with the Ignition Test Through Bottom-Panel Openings, Section [63](#).

Table 7.6
Perforated metal plates

Minimum thickness,		Maximum diameter of holes,		Minimum spacing of holes center-to-center,	
inch	(mm)	inch	(mm)	inch	(mm)
0.026	(0.66)	0.045	(1.14)	0.67	(1.70)
				[233 holes per inch ²]	[36 holes per cm ²]
0.026	(0.66)	0.047	(1.19)	0.093	(2.36)
0.032	(0.81)	0.075	(1.91)	0.125	(3.18)
				[72 holes per inch ²]	[11 holes per cm ²]
0.036	(0.91)	0.063	(1.60)	0.109	(2.77)
0.036	(0.91)	0.078	(1.98)	0.125	(3.18)

7.9.3 The bottom of the enclosure under areas containing only materials rated V-1 or less flammable shall have openings no larger than 1/16 inch² (40 mm²).

8 Internal Materials

8.1 Polymeric materials used within an enclosure shall be evaluated in accordance with the Standard for Polymeric Materials – Use in Electrical Equipment Evaluations, UL 746C.

Exception: Unrated resistors, capacitors, semiconductors, integrated circuit packages, optical isolators, and similar electrical components meet the intent of the requirement when they are mounted on a material with a minimum flammability rating of V-1.

8.2 All combustible material used within an enclosure shall be V-2, HF-2, or better.

Exception No. 1: Motors, relays, capacitors, semiconductors, transformers, switches, insulating tubing or tape, and other electrical elements are exempt from the above requirement when they comply with the flame test applicable to the component. Meter faces and cases (when determined capable for mounting live parts) and indicator lamps or jewels, or both, are exempt from flammability requirements. The following requirements apply to parts that are isolated either by at least 0.5 inch (12.5 mm) of air, or a solid

barrier of V-1 or less-flammable material from uninsulated electrical parts that involve a risk from electrical energy-high current levels:

- a) Gears, cams, belts, bearings, strain-relief bushings applied over PVC-jacketed cords, and other small parts that contribute negligible fuel to a fire are not required to be investigated, and
- b) Tubing for air or fluid systems, and plastics, shall not be more flammable than HB. Foamed plastics classed HBF in accordance with the Standard for Tests for Flammability of Plastic Materials for Parts in Devices and Appliances, UL 94, are determined as complying with this requirement.

Exception No. 2: Combustible material used within an enclosure is not prohibited from being HB when the power sources to the enclosure meet the criteria for no risk of fire as defined in [5.75](#).

9 Accessibility of Uninsulated Live Parts, Film-Coated Wire, and Moving Parts

9.1 To reduce the risk of unintentional contact and electric shock from an uninsulated live part or film-coated wire, and injury to persons from a moving part, an opening in an enclosure shall have a minor dimension less than 1 inch (25.4 mm), and such a part or wire shall not be contacted by the probe illustrated in [Figure 9.1](#).

ULNORM.COM : Click to view the full PDF of UL 2572 2024

9.2 The probe illustrated in [Figure 9.1](#) shall be applied to any depth that the opening will permit. The probe shall be rotated or angled before, during, and after insertion through the opening to any position that is required in order to examine the enclosure. The probe illustrated in [Figure 9.1](#) shall be applied in any possible configuration and, when necessary, the configuration shall be changed after insertion through the opening.

9.3 The probe illustrated in [Figure 9.1](#) shall be used as a measuring instrument to evaluate the accessibility provided by an opening, and not as an instrument to evaluate the strength of a material. It shall be applied with the minimum force required to determine accessibility.

9.4 During the examination of a product to determine whether it complies with the requirement in [9.1](#), a part of the enclosure that is to be opened or removed by the operator without using a tool (to attach an accessory, to make an operating adjustment, or for other reasons) shall be opened or removed.

10 Mechanical Assembly

10.1 All parts of a product shall be mounted in position and prevented from loosening or turning when such motion may adversely affect the performance of the product, or may increase the risk of fire, electric shock, and/or injury to persons incident to the operation of the product.

10.2 A switch, fuse holder, lampholder, attachment-plug receptacle, motor-attachment plug, or other similar component shall be mounted securely and shall not turn.

Exception No. 1: When the turning of a switch is possible, all four of the following conditions shall be met:

- a) The switch shall be of a plunger, slide, or other type that does not tend to rotate when operated. A toggle switch is determined to be subject to forces that tend to turn the switch during intended operation of the switch;*
- b) The means for mounting the switch makes it unlikely that operation of the switch loosens it;*
- c) The spacings are not reduced below the minimum required values when the switch rotates; and*
- d) The intended operation of the switch is by mechanical means rather than by direct contact by persons.*

Exception No. 2: When rotation does not reduce spacings below the minimum required value, a lampholder of the type in which the lamp cannot be replaced, such as a neon pilot or indicator light in which the lamp is sealed in a nonremovable jewel, complies with the intent of the requirement.

10.3 Friction between surfaces shall not be used for securing the position of the parts specified in [10.2](#).

10.4 A rotating part that by loosening presents a risk of fire, electric shock, electrical-energy/high-current levels, or injury to persons, shall be assembled so that the direction of rotation tends to tighten the means that hold the rotating part in place.

Exception: A keyed part, a press fit, a part locked in place with a pin, or means that have been determined to be equivalent, can be used to hold a rotating part in place.

10.5 Except as indicated in [10.6](#) – [10.9](#), all subassemblies, modules, and printed-wiring boards shall be held in their intended place in the product by mechanical means.

10.6 An adhesive that is relied upon to:

- a) Reduce a risk of fire, electric shock, or injury to persons,

- b) Limit access to a manual control, or
- c) Avert dislodgement of a part/module affecting normal operation of the product

shall comply with the requirements for adhesives in the Standard for Polymeric Materials – Use in Electrical Equipment Evaluations, UL 746C. The durability shall be representative of a minimum of 30 years of service at the maximum rated prevailing ambient installation temperature.

10.7 The requirement in [10.6](#) applies to an adhesive used to secure a part, including a nameplate, which may, if loosened or dislodged:

- a) Energize an accessible dead metal part,
- b) Make a live part accessible,
- c) Reduce spacings below the minimum required values,
- d) Short-circuit live parts,
- e) Make a limited-accessible control accessible, or
- f) Affect the normal operation of the product.

10.8 Whether the conditions specified in [10.7](#) (a) – (f) can occur is to be considered with respect to both:

- a) A part inside or outside of the device and
- b) A part on the outside of the device that may affect equipment in which the device is to be installed.

10.9 Parts secured using adhesive are to be installed in or on the product before leaving the factory.

11 Protection Against Corrosion

11.1 Iron and steel parts shall be protected against corrosion by enameling, galvanizing, plating, or other means that have been determined to be equivalent, when corrosion of unprotected parts results in a risk of fire, electric shock, injury to persons, or impairment of operation of a product.

Exception No. 1: Surfaces of sheet-steel and cast-iron parts within an enclosure are not required to be protected against corrosion when oxidation of the metal due to exposure to air and moisture is not likely to weaken the parts to result in a condition of risk. The thickness of metal and temperature are also to be evaluated.

Exception No. 2: Bearings, laminations, or minor parts or iron or steel, such as washers, screws, and similar equipment, are not required to be protected against corrosion.

12 Branch-Circuit Connection

12.1 General

12.1.1 Control units and accessories shall be provided with a means for permanent connection to the branch-circuit supply.

Exception: Video display terminals, other operator interface products, and printers installed within a supervising station that may be repositioned for normal use or maintenance.

12.2 Permanently connected

12.2.1 General

12.2.1.1 A product intended for permanent connection to the branch-circuit supply shall have provision for installing the supply conductors in rigid metallic conduit.

Exception: An enclosure without provisions for connection to rigid metallic conduit is acceptable when the installation instructions specifically indicate which sections of the enclosure may be drilled for the connection.

12.2.1.2 A knockout or other supply-connection opening located where temperatures in excess of 140°F (60°C) have been measured during the Component Temperature Test, Section 54, and not having qualifying marking as specified in 81.1.13, shall be sealed by welding or the equivalent or be permanently marked adjacent to the opening with: "Do Not Use".

12.2.2 Field-wiring compartment

12.2.2.1 The location of a terminal box or compartment, in which branch-circuit connections to a permanently-wired product are to be made, shall be such that the connections can be readily inspected without disturbing the wiring or the product after the product has been installed as intended.

12.2.2.2 A terminal compartment intended for connection of a supply raceway shall be attached to the product so that it does not turn.

12.2.2.3 The field-wiring compartment area of a product shall be of sufficient size for completing all wiring connections as specified by the installation wiring diagram.

12.2.2.4 Where damage to field-wiring insulation may be caused by internal components or sharp edges in the wiring compartment, insulating or metal barriers having smooth, rounded edges shall be provided or the following or equivalent wording marked in the wiring area: "CAUTION – When Making Installation, Route Field Wiring Away From Sharp Projections, Corners, and Internal Components".

12.2.2.5 The wiring terminals of a product intended for mounting in an outlet box shall be located or protected so that, upon installation, the wiring in the outlet box is not forced against the terminals or other sharp edges so as to damage the conductor insulation, and/or the terminals or stripped leads do not come into contact with the walls of the outlet box.

12.2.3 Field-wiring terminals and leads

12.2.3.1 A permanently connected product shall be provided with wiring terminals or leads for the connection of conductors having an ampacity not less than 125 percent of the current input of the product when connected to a power-supply voltage in accordance with 31.1.1 – 31.1.4.

12.2.3.2 The free length of a lead inside a terminal box or compartment shall be 6 inches (150 mm) or more, provided with strain relief, shall not be smaller than 18 AWG (0.82 mm²), and the insulation, when of rubber or thermoplastic, shall not be less than 0.030 inch (0.76 mm) minimum average and 0.027 inch (0.69 mm) minimum at any point when the lead is intended for field connection to an external circuit.

Exception: The lead shall be less than 6 inches (150 mm) long when it is evident that the use of a longer lead results in a risk of fire or electric shock

12.2.3.3 A field-wiring terminal shall be kept from turning or shifting in position by means other than friction between surfaces. This shall be accomplished by two screws or rivets, by square shoulders or mortises, by a dowel pin, lug or offset, by a connecting strap or clip fitted into an adjacent part, or by some other method determined to be the equivalent.

12.2.3.4 A field-wiring terminal shall comply with the requirements in [13.4](#) for field-wiring terminals (general application) except a wire-binding screw shall not have a diameter smaller than No. 8 (4.2 mm).

12.2.4 Identified terminals and leads

12.2.4.1 A permanently-connected product rated 125 or 125/250 V (3-wire) or less, and using a lampholder of the Edison screw-shell type, or a single-pole switch or overcurrent protective device other than an automatic control without a marked-off position, shall have one terminal or lead identified for the connection of the grounded conductor of the supply circuit. This terminal or lead shall be electrically connected to screw shells of lampholders and shall not be connected to switches or overcurrent protective devices of the single-pole type other than automatic controls without a marked-off position.

12.2.4.2 A terminal intended for the connection of a grounded supply conductor shall be of or plated with metal that is white in color and shall be distinguishable from the other terminals, or identification of that terminal shall be shown in some other manner, such as on an attached wiring diagram.

12.2.4.3 A lead intended for the connection of a grounded power-supply conductor shall be finished white or gray color and shall be distinguishable from the other leads.

12.2.5 Strain relief

12.2.5.1 A means of strain relief shall be provided for the field supply leads of a product to prevent any mechanical stress from being transmitted to terminals and internal connections. Inward movement of the leads provided with a ring-type strain relief or means determined to be the equivalent shall not damage internal connections or components, or result in a reduction of electrical spacings.

12.2.5.2 Each lead used for field connections or an internal lead subjected to movement or handling during installation and servicing shall be capable of withstanding for 1 minute a pull of 10 pounds (4.54 kg) without any evidence of damage or of transmitting the stress to internal connections.

12.3 Cord-connected product

12.3.1 Cords and plugs

12.3.1.1 A product shall be provided with a length of 5 – 15 feet (1.5 – 4.5 m) flexible cord and a grounded attachment plug when intended for connection to a line voltage branch-circuit supply. See [Table 12.1](#) and [Table 12.2](#).

Exception No. 1: A length of flexible cord of Type S, or cord determined to be equivalent, not exceeding 25 feet (7.5 m).

Exception No. 2: The length of the power-supply cord on an appliance intended for a special installation, such as dedicated equipment intended to be mounted near a receptacle may be less.

Exception No. 3: A polarized attachment plug, rather than a grounded attachment plug, when the product has no accessible dead-metal parts likely to be energized.

Exception No. 4: An attachment plug is not required to be polarized or grounded when there are no accessible dead-metal parts likely to be energized and no single-pole devices in primary circuits.

Exception No. 5: Double insulated equipment shall not be grounded. Refer to the Standard for Double Insulation Systems for Use in Electrical Equipment, UL 1097.

**Table 12.1
Grounding, polarization, and double insulation (DI) scheme requirements**

Product	Attachment plug
Connected to branch circuit with accessible dead metal	Grounding or insulation scheme of DI
Connected to branch circuit with no accessible dead metal	Grounding, polarization, or insulation scheme of DI
Connected to branch circuit with no accessible dead metal and no single-pole devices in primary circuits	Non-grounding, grounding, polarization, or insulation scheme of DI

**Table 12.2
Power supply cords**

Type of appliance	Type of cord
Table-model products (for use on a table, desk, and the like) that are not frequently moved	SV, SP-2, SP-3
Products that are intended for use on desks, counters, or tables and are moved frequently	SV, SP-2
Hand-held products	TS ^a , SV ^b
Floor-mounted products	SJ, S
Wall-mounted products	SV ^c , SP-2 ^c , SP-3 ^c , SJ, S
^a A tinsel cord shall be used when all of the following conditions are met: <ol style="list-style-type: none"> 1) The cord is no longer than 8 feet (2.4 m); 2) The cord is attached to the product directly or by means of a plug intended for that purpose; 3) The product rating is not higher than 50 W; and 4) The intended use of the appliance requires an extremely flexible cord. 	
^b Type SV and similar cords shall be used when each conductor is made up of 36 AWG (0.01 mm ²) strands.	
^c Type SV, SP-2, SP-3, and similar cords shall be used only when the cord is no longer than 5 feet (1.5 m).	

12.3.1.2 The flexible cord shall have a voltage rating not less than the rated voltage of the product, and shall have an ampacity that is not less than the current rating of the product.

12.3.1.3 The flexible cord on a cord-connected unit shall be as indicated in [Table 12.2](#) or shall be of a type at least as serviceable for the particular application. [Table 12.3](#) specifies cord types determined to be equivalent to those specified in [Table 12.2](#).

Table 12.3
Equivalent cords

Basic cord type	Equivalent types
TS	TST
SP-2	SPE-2, SPT-2
SP-3	SPE-3, SPT-3
SV	SVE, SVO, SVOO, SVT, SVTO, SVTOO
SJ	SJE, SJO, SJOO, SJT, SJTO, SJTOO
S	SE, SO, SOO, ST, STO, STOO

12.3.1.4 The current rating of the attachment plug shall not be less than 125 percent of the product nameplate rating.

12.3.1.5 The voltage rating of the attachment plug shall correspond to the rated voltage of the product. When a product is intended for use on two or more different values of voltage by field alteration of internal connections, the attachment plug provided with the product shall be rated for the voltage for which the product is wired when shipped from the factory.

12.3.1.6 The flexible cord shall be attached permanently to the product and means shall be provided to physically secure the attachment plug or plug-in transformer to the power receptacle so as to prevent accidental removal.

Exception: For monitors and other operator interface products, a detachable power-supply cord without physical securing means is suitable.

12.3.2 Strain relief

12.3.2.1 A power-supply cord shall be provided with strain-relief means to keep tension on the cord from being transmitted to terminals, splices, or wiring within the product. The strain-relief means provided shall comply with the Strain-Relief Test, Section [72](#).

12.3.2.2 Means shall be provided so that the flexible cord cannot be pushed into the product through the cord entry hole when such displacement results in damage to the cord or exposure of the cord to a temperature higher than that for which the cord is rated or can reduce spacings, such as to a metal strain-relief attachment, below the minimum required values.

12.3.2.3 A metal strain-relief clamp or band (without auxiliary protection) has been determined to be suitable with Type SJ, S, SJT, ST or similar jacketed cords. A metal strain-relief clamp or band has been determined to be suitable with Type SV, SP-2, SPT-2, or SVT cords only when nonconducting auxiliary mechanical protection is provided over the cord.

12.3.2.4 A knot shall not be used to provide strain relief.

12.3.2.5 When tested in accordance with [72.1.1](#) – [72.1.3](#), the strain-relief means provided on the flexible cord shall be capable of withstanding for one minute, a pull of 35 pounds (15.9 kg) applied to the cord, with no evidence of stress on the interior connections.

12.3.3 Bushings

12.3.3.1 At the point at which a supply cord passes through an opening in a wall, barrier, or the overall enclosure, there shall be a bushing or a determined equivalent that shall be secured in place, and shall

have a smooth, well-rounded surface against which the cord tends to bear. When other than a jacketed cord is used and the wall or barrier is of metal, an insulation bushing shall be provided.

12.3.3.2 When the cord hole is in porcelain, phenolic composition, or another rated nonconducting material, a smooth, well-rounded surface is determined equivalent to a bushing.

12.3.3.3 Ceramic materials and some molded compositions are capable of being used for insulating bushings.

12.3.3.4 Vulcanized fiber is not prohibited from being used when the bushing is not less than 3/64 inch (1.2 mm) thick and is formed and secured in place so that it will not be affected adversely by conditions of ordinary moisture.

12.3.3.5 A separate soft-rubber, neoprene, or polyvinyl chloride bushing shall only be used on a supply cord where the cord enters the frame of a motor or the enclosure of a capacitor that is physically attached to a motor when the bushing is:

- a) Not less than 3/64 inch (1.2 mm) thick and
- b) Located so that it will not be exposed to oil, grease, oil vapor, or other substances that tend to have a deleterious effect on the compound used.

12.3.3.6 A bushing of any of the materials specified in [12.3.3.5](#) on a supply cord anywhere in a product is acceptable when it is used in conjunction with a type of cord for which an insulating bushing is not required. The edges of the hole in which such a bushing is used are required to be free from burrs, fins, and other conditions that could damage the bushing.

12.3.3.7 At any point in a product, a bushing of the same material as, and molded integrally with, the supply cord is capable of being used on a Type SP-2 or heavier cord, when the thinnest section is not less than 1/16 inch (1.6 mm) thick at the point where the cord passes through the enclosure.

12.3.3.8 An insulated metal grommet to be used in place of an insulating bushing meets the intent of the requirement, when the insulating material used is not thinner than 1/32 inch (0.8 mm) and completely fills the space between the grommet and the metal in which the grommet is mounted.

13 Other Field-Wiring Connections

13.1 General

13.1.1 A product shall be provided with wiring terminals or leads for the connection of conductors of at least the size required by the National Electrical Code, ANSI/NFPA 70, corresponding to the rating of the circuit.

13.1.2 All field-wiring connections shall be contained in either an enclosed field wiring compartment integral with the product or in a separate outlet box to which the product is to be mounted.

13.1.3 Duplicate terminals or leads, or an equivalent arrangement, shall be provided for circuits of products intended to be connected to initiating-device circuits, notification appliance circuits, or non-addressable signaling line circuits of a control unit; one for each incoming and one for each outgoing wire. It is not prohibited that a common terminal be used in lieu of duplicate terminals when it is intended to prevent the looping of an unbroken wire around or under a terminal screw in a manner that permits the looped wire to remain unbroken during installation, thereby precluding supervision in the event the wire becomes dislodged from under the terminal. A notched clamping plate under a single securing screw, where separate conductors are intended to be inserted in each notch, is an equivalent arrangement. When

duplicate terminals or leads are not used and there is no provision to prevent looping an unbroken wire around or under one terminal, the information in [82.12](#) shall be included in the installation wiring diagram/instructions.

13.2 Field-wiring compartment

13.2.1 There shall be adequate space within a terminal or wiring compartment to permit the use of a standard conduit bushing when a bushing is required for installation.

13.2.2 The field-wiring compartment area of a product to which connections are to be made is to be of sufficient size for completing all wiring connections as specified by the installation wiring diagram.

13.2.3 Where it is possible for damage to field-wiring insulation to be caused by internal components or sharp edges in the wiring compartment, insulating or metal barriers having smooth, rounded edges shall be provided or the following (or wording determined to be the equivalent) marked in the wiring area: "CAUTION – When Making Installation, Route Field Wiring Away From Sharp Projections, Corners And Internal Components."

13.2.4 The wiring terminals of a product intended for mounting in an outlet or junction type box shall be located or protected so that, upon installation:

- a) The wiring in the outlet box is not forced against the product, product's terminals, or sharp edges so as to damage the conductor insulation or product's unprotected components, and/or
- b) A product with exposed wiring terminals shall be held in its intended mounting location inside the box by mechanical means.

13.3 Class 2 or 3 circuits

13.3.1 When the design of the product is such that the product either requires or permits Class 2 or 3 circuit conductors to occupy the same enclosure as electric light, power, Class 1, or non-Class 2 or 3 emergency communication signaling circuit conductors, or medium-power network-powered broadband communications-circuit conductors, both of the conditions in (a) and (b) shall be met:

- a) The enclosure shall provide one or more cable openings into the enclosure. When a single opening is provided, a continuous and firmly fixed nonconductor, such as flexible tubing, shall be provided. This is required so that the Class 2 or 3 conductors are segregated from electric light, power, Class 1 conductors, non-Class 2 or 3 emergency communication signaling conductors, and medium-power network-powered broadband communications-circuit conductors. The installation document of the product shall completely detail cable entry routing of all conductors into the product.
- b) The product shall be constructed so that, with all field-installed wiring connected to the product, either:
 - 1) A minimum 1/4 inch (6.4 mm) is provided between all Class 2 or 3 conductors and all electric light, power, Class 1 conductors, non-Class 2 or 3 emergency communication signaling conductors, or medium-power network-powered broadband communications-circuit conductors, or

- 2) For circuit conductors operating at 150 volts or less to ground where the Class 2 or 3 conductors are installed using Types FPL, FPLR, FPLP, or equivalent cables, a minimum 1/4 inch (6.4 mm) separation is provided between these Class 2 or 3 cable conductors extending beyond the jacket and all electric light, power, Class 1 conductors, non-Class 2 or 3 emergency communication signaling conductors, and medium-power network-powered broadband communications-circuit conductors.