



# UL 2442

## STANDARD FOR SAFETY

Wall- and Ceiling-Mounts and  
Accessories

[ULNORM.COM](https://www.ulnorm.com) : Click to view the full PDF of UL 2442 2023

[ULNORM.COM](https://ULNORM.COM) : Click to view the full PDF of UL 2442 2023

UL Standard for Safety for Wall- and Ceiling-Mounts and Accessories, UL 2442

Second Edition, Dated June 18, 2019

### **Summary of Topics**

***This revision of ANSI/UL 2442 dated January 13, 2023 includes clarification of a Trained Person; [2.47A](#)***

Text that has been changed in any manner or impacted by UL's electronic publishing system is marked with a vertical line in the margin.

The new requirement is substantially in accordance with Proposal(s) on this subject dated December 9, 2022.

All rights reserved. No part of this publication may be reproduced, stored in a retrieval system, or transmitted in any form by any means, electronic, mechanical photocopying, recording, or otherwise without prior permission of UL.

UL provides this Standard "as is" without warranty of any kind, either expressed or implied, including but not limited to, the implied warranties of merchantability or fitness for any purpose.

In no event will UL be liable for any special, incidental, consequential, indirect or similar damages, including loss of profits, lost savings, loss of data, or any other damages arising out of the use of or the inability to use this Standard, even if UL or an authorized UL representative has been advised of the possibility of such damage. In no event shall UL's liability for any damage ever exceed the price paid for this Standard, regardless of the form of the claim.

Users of the electronic versions of UL's Standards for Safety agree to defend, indemnify, and hold UL harmless from and against any loss, expense, liability, damage, claim, or judgment (including reasonable attorney's fees) resulting from any error or deviation introduced while purchaser is storing an electronic Standard on the purchaser's computer system.

No Text on This Page

ULNORM.COM : Click to view the full PDF of UL 2442 2023

**JUNE 18, 2019**  
(Title Page Reprinted: January 13, 2023)



**ANSI/UL 2442-2023**

1

**UL 2442**

**Standard for Wall- and Ceiling-Mounts and Accessories**

First Edition – March, 2011

**Second Edition**

**June 18, 2019**

This ANSI/UL Standard for Safety consists of the Second Edition including revisions through January 13, 2023.

The most recent designation of ANSI/UL 2442 as an American National Standard (ANSI) occurred on January 13, 2023. ANSI approval for a standard does not include the Cover Page, Transmittal Pages, and Title Page.

Comments or proposals for revisions on any part of the Standard may be submitted to UL at any time. Proposals should be submitted via a Proposal Request in UL's On-Line Collaborative Standards Development System (CSDS) at <https://csds.ul.com>.

Our Standards for Safety are copyrighted by ULSE Inc. Neither a printed nor electronic copy of a Standard should be altered in any way. All of our Standards and all copyrights, ownerships, and rights regarding those Standards shall remain the sole and exclusive property of ULSE Inc.

**COPYRIGHT © 2023 ULSE INC.**

ULNORM.COM - Click to view the full PDF of UL 2442 2023

No Text on This Page

[ULNORM.COM](https://ULNORM.COM) : Click to view the full PDF of UL 2442 2023

**CONTENTS**

**PART 1 – ALL MOUNTING SYSTEMS**

**INTRODUCTION**

1 Scope .....7

2 Glossary .....8

3 Components .....12

4 Units of Measurement .....12

5 Undated References .....12

**CONSTRUCTION**

**GENERAL**

6 General .....12

7 Accessories .....12

8 Assemblies of Parts .....13

9 Dropped or Suspended Ceilings .....14

10 Other Spaces Used for Environmental Air (Plenums) .....14

**ELECTRICAL CONSTRUCTION**

11 General .....15

12 Electrical Enclosures .....16

13 Enclosure Openings .....17

14 Screens and Expanded Metal .....24

15 Doors and Covers .....25

16 Screws and Mechanical Connections for Electrical Enclosures .....26

17 Electrical Spacings .....26

18 Electrical Insulating Materials .....28

19 Electrical Ratings .....28

20 Wiring and Conductors – Conductor Size .....28

21 Splices and Connections .....29

22 Wiring Attached to Movable or Flexible Parts .....30

23 Internal Wiring .....30

24 Supply Connections .....31

    24.1 Power-supply cords .....31

    24.2 Permanently-connected .....33

25 Attachment Plugs .....35

26 Interlock Switch .....36

27 Interconnected Units .....36

28 Polarization and Identification .....37

29 Grounding .....38

30 Bonding .....40

31 Safety Circuits .....40

32 Control Circuits .....41

33 Laser Devices .....41

34 Motors .....42

    34.1 Motor construction .....42

    34.2 Motor overload protection .....42

35 Requirements for Loads on the Output of a NEC Class 2, LPS or SELV Power Supply .....43

35.1	Motor controllers .....	43
35.2	Electrical enclosures .....	44
35.3	Luminaires .....	45
35.4	Interconnecting cables .....	45
35.5	Connectors .....	45

## MECHANICAL CONSTRUCTION

36	Mounting of Parts .....	45
37	Flammability of Mounts .....	45
38	Adhesives Used to Secure Parts .....	46
39	Fasteners .....	47
40	Lubrication .....	47
41	Corrosion Protection .....	47
42	Wireways and Tubing .....	47
43	Strain Relief .....	48
44	Bushings .....	48
45	Thermal Insulation .....	49
46	Glass Panels .....	49
47	Counter Balance Mechanisms .....	49
48	Sharp Edges .....	49
49	Securement of Products for Use with the Mounting System .....	49
50	Mounting System Ventilation .....	50
51	Articulating Motor Operated Mounting Systems .....	50
51.1	Mechanical enclosures and guards .....	50
51A	Interlocked Control For Motor-Operated Articulating Mounts .....	52
52	User/Installer Assembly .....	53
53	Knockouts .....	54
53.1	Clearance .....	54
53.2	Flat surfaces surrounding knockouts .....	54
53.3	Diameters .....	54
53.4	Strength of knockouts .....	54

## PERFORMANCE

### GENERAL

54	General .....	55
----	---------------	----

### ELECTRICAL PERFORMANCE TESTS

55	Leakage Current Test .....	60
56	Leakage Current Test Following Humidity Conditioning .....	62
57	Starting Current Test .....	62
58	Input Test .....	62
59	Temperature Test .....	63
60	Dielectric Voltage-Withstand Test .....	66
61	Strain Relief Test .....	67
62	Push-Back Relief Test .....	67
63	Performance Requirements for Loads on the Output of a NEC Class 2, LPS or SELV Power Supply .....	67
63.1	Motors .....	67
63.2	Running overload test .....	68
63.3	Locked rotor test .....	68

**MECHANICAL PERFORMANCE TESTS**

64 Mold Stress Test.....68

65 Impact Tests .....69

    65.1 Mount impact test (Plastic parts only) .....69

    65.2 Electrical enclosure impact test.....70

    65.3 Glass parts – impact test .....70

66 Cycling Test for Articulating Mounts .....71

67 Mounting Securement Test.....73

    67.1 Supporting structures.....73

    67.2 Test procedure .....75

68 Adhesive Test .....76

69 Sharp Edge Test.....76

70 Multiple Knockouts Test .....76

71 Flat Areas Surrounding Knockouts.....77

**MARKINGS**

72 Rating Details .....80

73 General .....80

74 Motor-Operated Mounting Systems .....81

75 Interconnected Units.....82

76 Permanently Electrically-Connected Mounting Systems .....82

77 Supporting Surface Load Marking.....82

**INSTRUCTIONS**

78 General .....85

79 Mounting Instructions .....86

80 Operating Instructions.....87

81 User-Maintenance Instructions.....89

82 Grounding and Double Insulation Instructions.....89

83 Interconnected Units Instructions.....91

84 Other Spaces Used for Environmental Air (Plenums) .....91

**PART 2 – OUTDOOR MOUNTING SYSTEMS**

**INTRODUCTION**

85 General .....91

86 Glossary .....91

**CONSTRUCTION**

87 General .....91

88 Gaskets and Seals .....93

89 Polymeric Materials .....93

90 Receptacle Outlets .....93

**PERFORMANCE**

91 General .....93

92 Rain Test .....93

93 Tensile Strength and Elongation Test .....97

94 Compression Test .....97

**MARKINGS**

95 General .....99

ULNORM.COM : Click to view the full PDF of UL 2442 2023

## PART 1 – ALL MOUNTING SYSTEMS

### INTRODUCTION

#### 1 Scope

1.1 These requirements apply to shelves, brackets, and similar devices, that provide structural support for the mounting of audio/video equipment, information technology equipment, and similar products, to the building structure as the primary support means (it is not touching the floor) and are intended for indoor use only.

1.2 These requirements also apply to accessories that are used to expand the capability of a mounting device; accessories that are used to secure the mounting device to a wall, ceiling, suspended ceiling, truss, joist, "I" beam, or other building structural component specified by the manufacturer; and any accessories used to secure an apparatus to the mount. Examples of such products include extension columns, extension arms, ceiling plates, floor plates, ceiling brackets, fastener kits, and VCR/DVD brackets.

1.3 A furnishing intended to support audio equipment or a video display (such as CRT, LCD, and Plasma) is to be evaluated in accordance with one of the following:

- a) A furnishing such as a desk, motorized cart or stand, or a retail store display intended to support a video display, but not intended for use as a non-motorized cart or stand for a video display is covered by the Standard for Household and Commercial Furnishings, UL 962;
- b) A video display sign is covered by the Standard for Electric Signs, UL 48;
- c) If the non-motorized furnishing is provided with casters, wheels, or is an entertainment center, the Standard for Household, Commercial, and Institutional-Use Carts, Stands and Entertainment Centers for Use with Audio and/or Video Equipment, UL 1678 applies;
- d) If the audio or video equipment is intended to be mounted to walls, ceilings or another permanent part of a building as the primary support means (it is not touching the floor), this standard applies;
- e) If a furnishing is supplied with all of the video and/or audio components by the manufacturer of those components, the requirements contained in the Standard for Audio, Video and Similar Electronic Apparatus – Safety Requirements, UL 60065, or the Standard for Information Technology Equipment – Safety – Part 1: General Requirements, UL 60950-1, or the Standard for Safety for Audio/Video, information and communication technology equipment – Part 1: Safety Requirements, UL 62368-1, apply as appropriate.

*Exception: A video display support system evaluated in accordance with (a) – (d) above and supplied with all of the video and/or audio components is not subject to (e).*

1.4 These requirements do not apply to carts and stands. The Standard for Safety for Household, Commercial, and Institutional-Use Carts, Stands and Entertainment Centers for Use with Audio and/or Video Equipment, UL 1678, applies to non-motorized carts and stands, and the Standard for Household and Commercial Furnishings, UL 962, applies to motorized carts and stands.

1.5 These requirements do not apply to a mounting device provided with a specific product when the specific product standard is provided with requirements to address the mounting device. Such combinations are covered by the applicable requirements of the end-use product standard.

1.6 These requirements do not cover products intended for use in patient care areas. Patient care products are covered by the Standard for Medical Electrical Equipment, Part 1: General Requirements for Safety, UL 60601-1.

1.7 These requirements do not cover products that are specifically intended for infants or juveniles.

1.8 These requirements do not cover the mount to supported apparatus interface.

## 2 Glossary

2.1 For the purpose of this standard, the following definitions apply.

2.2 APPARATUS – Video display, computer, amplifier, speaker and similar components intended to be supported by the mounting system.

2.3 ATTENDED EQUIPMENT – Equipment intended for use where operator presence is required for the equipment to function but is not necessarily required for the equipment to operate.

2.4 BALLAST – A current limiting device required to start and operate fluorescent and cold cathode lamps.

2.5 BULB (LAMP) – A device which emits light.

2.6 CLASS 2 CIRCUIT – An isolated secondary circuit involving a potential of not more than 30-volt rms maximum 42.4 volts peak open circuit secondary potential under any condition of loading or open circuit. There shall be no electrical connection between the primary and secondary windings of a transformer or between a primary or secondary circuit and the enclosure.

a) An inherently-limited Class 2 transformer;

b) A combination of an isolated transformer secondary winding and a fixed impedance or regulating network that together comply with the performance requirements for an inherently limited Class 2 transformer; or

c) One or more combinations of a transformer and an overcurrent protective device that together comply with the performance requirements for a noninherently-limited Class 2 transformer.

2.7 CLEARANCE DISTANCE – The shortest distance measured through air between conductive parts.

2.8 DECORATIVE PART – A part of the mounting system that has no safety function.

2.9 DEDICATED STORAGE AREA – An integral part of a mounting system intended to accommodate specific accessories such as media tapes and discs.

2.10 DETACHABLE POWER-SUPPLY CORD – A flexible cord, for supply purposes, able to be connected to or disconnected from the mounting system by means of a suitable mounting system coupler.

2.11 NON-DETACHABLE POWER-SUPPLY CORD – A flexible cord, for supply purposes, fixed to or assembled with the mounting system.

2.12 ENCLOSURE, ELECTRICAL – That part of the mounting system that:

a) Renders inaccessible all or any parts of the equipment that may otherwise present a risk of electric shock; and/or

- b) Retards propagation of flame initiated by electrical disturbances occurring within.
- 2.13 ENCLOSURE, MECHANICAL – A part of the mounting system intended to reduce the risk of injury due to mechanical and other physical hazards.
- 2.14 EXPOSED PART – A part that is not enclosed to prevent contact.
- 2.15 FLAMMABILITY CLASSIFICATION – The flammability classification of a material is determined by tests described in the Standard for Tests for Flammability of Plastic Materials for Parts in Devices and Appliances, UL 94, or for surfaces greater than 10 square feet, the Standard for Test for Surface Burning Characteristics of Building Materials, UL 723.
- 2.16 FRICTION MATERIAL – Rubber or elastomer with or without dimples or ridges. Plastic or metal with or without dimples or ridges is not a friction material.
- 2.17 GLAZING – To furnish or fit with glass or a clear polymer.
- 2.18 GUARD – That portion of the mounting system that reduces the risk of electric shock or injury to persons.
- 2.19 HAZARDOUS SUBSTANCES AND ARTICLES – As defined by the United States Code of Federal Regulations 16 CFR PART 1500 to 1512.
- 2.20 INSTALLER ASSEMBLY – Any mechanical assembly and installation of a mounting system performed by a trained installer.
- 2.21 INSULATION
- a) INSULATION SYSTEM – An assembly of insulating materials used to isolate the live parts from ground and from parts of opposite polarity. All materials in contact with the windings are considered part of the system.
  - b) BASIC INSULATION – Insulation to provide basic protection against electric shock.
  - c) SUPPLEMENTARY INSULATION – Independent insulation applied in addition to BASIC INSULATION in order to reduce the risk of electric shock in the event of a failure of the BASIC INSULATION.
  - d) DOUBLE INSULATION – Insulation comprising both BASIC INSULATION and SUPPLEMENTARY INSULATION.
  - e) REINFORCED INSULATION – A single insulation system which provides a degree of protection against electric shock equivalent to DOUBLE INSULATION under the conditions specified in this standard.
- 2.22 INTERLOCK – A switch or other device that de-energizes the load when an enclosure or guard is opened, displaced, or the mount is serviced.
- 2.23 INTERMITTENT DUTY MOTOR – A motor intended to be connected to a load other than a fan or blower and that is intended to operate for a specified time period.
- 2.24 INTERMITTENT OPERATION EQUIPMENT – Operation in a series of specified cycles each composed of a period of operation under NORMAL LOAD, followed by a rest period with the equipment switched off or running idle.

2.25 ISOLATED SECONDARY CIRCUIT – A circuit derived from an isolated secondary winding of a transformer and that has no direct connection back to the line-connected circuit (other than through grounding means). A secondary circuit that has a direct connection back to the line-connected circuit is part of the line-connected circuit.

2.26 LIMITED POWER SOURCE (LPS) – A limited power source is as defined in the Standard for Information Technology Equipment Safety – Part 1: General Requirements, UL 60950-1, and that complies with the requirements of UL 60950-1 or the Audio/Video, Information and Communication Technology Equipment – Part 1: Safety Requirements, UL 62368-1.

2.27 LIVE PART – A conductive part that has a potential difference during operation with respect to ground or any other conductive part.

2.28 LOCKED-ROTOR CURRENT – The current measured from the line when the armature or rotor is prevented from rotating.

2.29 LOW-VOLTAGE CIRCUIT – A circuit involving a potential of not more than 30 volts alternating current (42.4 peak) open circuit.

2.30 MOTOR-OPERATED MOUNTING SYSTEM – A mounting system provided with a motor for movement of some portion of the mounting system.

2.31 MOUNTING BRACKET – The interface that attaches the apparatus to a mounting system.

2.32 MOUNTING SURFACE – The building structure intended to fasten to or support the mounting device.

2.33 MOUNTING SYSTEM – A device that allows an apparatus to be attached to a building structure.

2.34 MOUNTING SYSTEM TYPES

a) STATIC MOUNT – A mounting device designed as a single component or constructed of nonadjustable components intended to support an apparatus in a fixed position.

b) ADJUSTABLE MOUNT – A mounting system designed with components that may be adjusted once (or infrequently) and intended to support the apparatus in a fixed position after assembly and installation. All joints and connections of an adjustable mount shall be rigid when assembled according to the installation and assembly instructions.

c) ARTICULATING MOUNT – A mounting system intended to allow active movement, adjustment, and/or repositioning, after installation.

d) MOTOR OPERATED ARTICULATING MOUNT – A motor-operated mounting system intended to allow frequent movement, adjustment, and/or repositioning, after installation.

2.35 NORMAL MAINTENANCE AND USE – The cleaning, adjusting, moving, maintaining, and using of the mounts. Includes items such as:

- a) Replacing a lamp, starter or fuse;
- b) Adjustment of a movable, removable or flexible part; and
- c) Removal or cleaning of all parts not secured by use of tools.

2.36 OPEN MOTOR – A motor having ventilating openings that provide for the passage of external cooling air over and around the windings.

2.37 ORDINARY TOOLS – Tools which are normally expected to be available to the user for installing the mounting system, such as flat-bladed and cross-recessed head (Phillips-type) screwdrivers, hammers, nut drivers, wrenches, pliers, electric drills, and similar tools, or those provided with the product.

2.38 POLYMERIC MATERIAL – Thermoplastic, thermosetting, and elastomeric materials.

2.39 PRINTED-WIRING BOARD (PWB) – The finished combination of a pattern of conductive paths either on or within multilayer sheets of insulating material.

2.40 RISK OF ELECTRIC SHOCK – A risk of shock exists between any two uninsulated conductive parts or between an uninsulated conductive part and earth ground, if the continuous current flow through a 1500 ohm resistor in parallel with a 0.015  $\mu$ F capacitor connected between the two points exceeds a 5 mA rms (7 mA peak) and if the open circuit voltage exceeds 30 V rms (42.4 V peak) for dry and damp or 15 V rms (21.2V peak) for wet locations.

2.41 SAFETY CIRCUIT – A circuit involved with sensing the presence of a user or bystander which is in danger of risk of injury from the mounting system and places or stops the mounting system in a position that prevents a risk of injury to a user or bystander under normal and abnormal circuit operation.

2.42 SAFETY INTERLOCK – A means either of preventing access to a hazardous area until the hazard is removed, or of automatically removing the hazardous condition when access is gained.

2.43 SECONDARY CIRCUIT – A circuit that is supplied by an induced voltage from a primary where a primary circuit is that supplied by a branch circuit.

2.44 SUPPORTING SURFACE – Any surface (shelf, platform, mounting bracket or similar surface) that is intended to support products such as audio/video equipment, information technology equipment, and video and audio discs and tapes.

2.45 THERMAL-DEVICE-PROTECTED MOTOR – A motor that relies upon a device (protector) to prevent overheating.

2.46 THERMAL PROTECTOR – A device installed integrally within a motor that is responsive to motor current and temperature or temperature only and that, when applied as intended, prevents overheating. Types are: thermal cutoff, automatically reset, manually reset and single-operation.

2.47 TOTALLY-ENCLOSED MOTOR – A motor that is enclosed to prevent the free exchange of air between the inside and outside of the winding enclosure and not so enclosed as to be airtight.

2.47A TRAINED PERSON – A person with relevant training and education in the operation of the mount, including safety, to enable them to identify hazards and to take appropriate actions to reduce risks of injury to themselves or others.

2.48 USER ADJUSTABLE FASTENER – A fastener or pivot of an Adjustable Mount intended to be loosened or tightened to allow adjustment or to provide tension adjustment for an Articulating Mount.

2.49 USER ASSEMBLY – Any mechanical assembly and installation of a mounting system performed by the user.

2.50 USER SERVICING – See Normal Maintenance and Use, [2.35](#).

### 3 Components

3.1 Except as indicated in 3.2, a component of a product covered by this standard shall comply with the requirements for that component.

3.2 A component is not required to comply with a specific requirement that:

- a) Involves a feature or characteristic not required in the application of the component in the product covered by this standard, or
- b) Is superseded by a requirement in this standard.

3.3 A component shall be used in accordance with its rating established for the intended conditions of use.

3.4 Specific components are incomplete in construction features or restricted in performance capabilities. Such components are intended for use only under limited conditions, such as certain temperatures not exceeding specified limits, and shall be used only under those specific conditions.

### 4 Units of Measurement

4.1 Values stated without parentheses are the requirement. Values in parentheses are explanatory or approximate information.

### 5 Undated References

5.1 Any undated reference to a code or standard appearing in the requirements of this standard shall be interpreted as referring to the latest edition of that code or standard.

## CONSTRUCTION

### GENERAL

#### 6 General

6.1 A mounting device shall be constructed so that:

- a) User assembly and normal use do not result in a risk of fire, electric shock, or injury to persons; and
- b) The materials and components are used within their mechanical, electrical, and temperature limits.

#### 7 Accessories

7.1 A mounting device having provisions for the use of a mechanical or electrical accessory intended to be attached in the field shall comply with the requirements in this standard, with or without the accessory installed.

7.2 Installation of an electrical accessory by the user shall be by means of keyed mating electrical connectors.

7.3 When an accessory is to be installed by the user, the mounting device shall comply with this Standard before and after the installation of the accessory.

7.4 The installation of electrical connectors of an installer-assembled accessory shall be by means of receptacles, plug-in connectors, insulated wire connectors, or by connection to existing wiring terminals.

7.5 With reference to [7.4](#), an installation shall not require the cutting of wiring or the soldering of connections by the installer. Installations shall not require cutting, drilling, or welding in electrical enclosures and in other areas where such operations may damage electrical components and wiring within the enclosure.

7.6 A means for strain relief of wires and cords shall be provided and comply with the Strain Relief Test, Section [61](#), and the Push-Back Relief Test, Section [62](#), for the wiring in the accessory if there is a possibility of transmitting stress to the terminal connections during installation.

7.7 All terminals and wiring intended to be field connected shall be identified on the accessory, on the mounting device if connections are made between the mounting device and the apparatus, and on the wiring diagram.

7.8 The intended installation of the accessory shall be indicated in the installation instructions included on or with the accessory. See [78.3](#).

7.9 As part of the investigation, an accessory is to be trial installed to determine that the installation is feasible, the instructions are detailed and correct, and the use of the accessory does not introduce a risk of electric shock, fire, or injury to persons.

## 8 Assemblies of Parts

8.1 A mounting system or systems comprised of parts that some or all of the parts can be used in different combinations and configurations to support the audio/video equipment shall comply with [8.2](#) – [8.4](#).

8.2 The recommended configurations when assembled in accordance with the manufacturers installation instructions shall comply with the construction and performance requirements in each of the configurations specified in the installation instructions.

8.3 When the parts of the system are assembled as specified in the installation instructions, no part of the assembly shall support more weight than the lowest load rating of any individual part. See [Figure 8.1](#) as an example. The weight of the system parts shall be considered in the total supported weight rating specified in the instructions.

**Figure 8.1**  
**Acceptable Combinations of Assemblies**

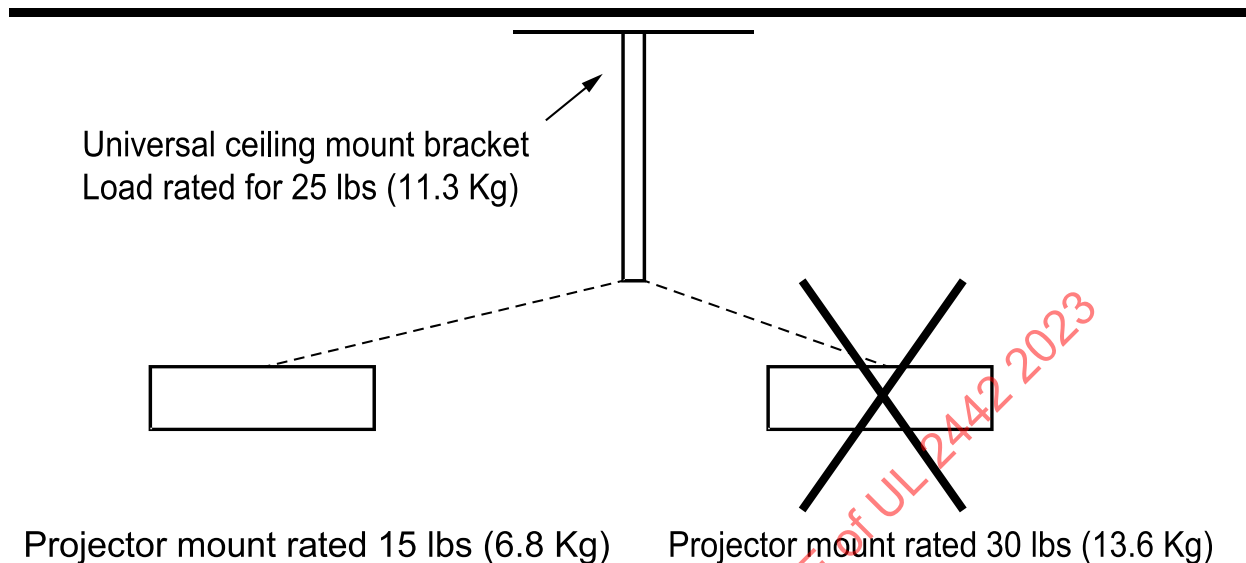

su2112

8.4 Installation instructions shall be provided as indicated in General, Section [78](#).

## 9 Dropped or Suspended Ceilings

9.1 The weight of an audio/video support system shall not be carried by a dropped or suspended ceiling. The weight of the support system and the audio/video components of the support system shall be supported independently from the dropped or suspended ceiling by attachment to the building structure.

## 10 Other Spaces Used for Environmental Air (Plenums)

10.1 A support system that extends above a suspended ceiling that is intended for use in "Other spaces used for environmental air (Plenums)" shall comply with the following:

- a) Enclosure systems intended to be installed in air-handling spaces shall be constructed of metal or constructed of non-metallic material that complies with the requirements in the Standard for Fire Test for Heat and Visible Smoke Release for Discrete Products and Their Accessories Installed in Air-Handling Spaces, UL 2043.

Note 1: The space over a hung ceiling used for environmental air-handling purposes is an example of air handling spaces to which this section applies. 300.22 (C) of National Electrical Code, ANSI/NFPA 70, describes these spaces as "other spaces used for environmental air (plenums)", or "spaces not specifically fabricated for environmental air-handling purposes".

Note 2: Products evaluated in accordance with these requirements are considered to comply with the fire retardant and low smoke producing requirements of Article 300 of National Electrical Code, ANSI/NFPA 70, Chapter 4 of the Standard for the Installation of Air-Conditioning and Ventilating Systems, NFPA 90A, Article 602 of the International Mechanical Code, and Article 602 of the Uniform Mechanical Code.

b) Enclosure systems intended for installation in air-handling spaces shall limit the amount of smoke that may enter the space in the event of a fire in any installed equipment. Openings in sections of the enclosure that separate installed equipment from the air-handling spaces shall be limited to small mounting holes, narrow slots associated with unused/unpunched knockouts, and the like. An example of a construction that complies with this requirement is as follows:

Openings in the enclosure that are not closed during the assembly and comply with the following:

- 1) The largest dimension of an opening shall not be more than 6.4 mm (1/4 in) and the smallest dimension shall not be more than 1.6 mm (1/16 in);
- 2) There shall be a maximum of five openings in any one side or end of the enclosure and the total area of all openings shall not be more than 1.3 cm<sup>2</sup> (0.2 in<sup>2</sup>); and
- 3) There shall be a maximum of 15 openings in the enclosure and the total area of all openings shall not be more than 3.2 cm<sup>2</sup> (0.5 in<sup>2</sup>) enclosure.

10.2 A support system that complies with [9.1](#) shall be marked according to the following:

- a) An enclosure system investigated for use in other spaces used for environmental air (spaces not specifically fabricated for environmental air-handling purposes but used for air-handling purposes, such as a plenum) may be marked "Suitable for Use in Other Space Used for Environmental Air (Plenums)", "Suitable for Use in Air-handling Spaces", or equivalent wording.
- b) Since enclosure systems covered by these requirements are not intended to house equipment that takes action on or senses the air in Ducts Specifically Fabricated for Environmental Air (see 300.22 (B) of the National Electrical Code, ANSI/NFPA 70), it is not permitted to identify enclosure systems either by marking or instructions as being suitable for use in ducts specifically fabricated for environmental air.
- c) An enclosure system intended for installation in air handling spaces that is provided with knockouts or removable panels shall be provided with instructions that require any punched openings to be sealed with a plug constructed of metal or a nonmaterial complying with the Standard for Fire Test for Heat and Visible Smoke Release for Discrete Products and Their Accessories Installed in Air-Handling Spaces, UL 2043, or the Standard for Fire Tests of Through-Penetration Firestops, UL 1479, and any covers or panels to be replaced and secured.
- d) An enclosure system that is designed for use in drop-ceiling constructions and similar applications that are commonly used for environmental air but is not intended to be used in air handling spaces shall be clearly marked "Not for use in air handling spaces".

10.3 A support system that complies with [10.1](#) shall be provided with installation instructions in accordance with Other Spaces Used for Environmental Air (Plenums), Section [84](#).

## ELECTRICAL CONSTRUCTION

### 11 General

11.1 A mount system that employs an electromagnetic interference filter shall also comply with the Standard for Electromagnetic Interference Filters, UL 1283. A product that employs a transient voltage surge suppressor shall also comply with the Standard for Surge Protective Devices, UL 1449. Telephone equipment and communication circuit protectors included in a mounting system shall comply with the requirements in the Standard for Information Technology Equipment – Safety – Part 1: General Requirements, UL 60950-1 or the Audio/Video, Information and Communication Technology Equipment – Part 1: Safety Requirements, UL 62368-1, and the requirements in the Standard for Secondary Protectors for Communications Circuits, UL 497A, respectively. A mounting system that incorporates an antenna

discharge unit or provides antenna connections to a television, a high-voltage video product, or antenna shall comply with the applicable requirements in the Standard for Antenna Discharge Units, UL 452, and the Standard for Audio-Video Products and Accessories, UL 1492. A product that employs ground-fault protection shall comply with the requirements in the Standard for Ground-Fault Circuit Interrupters, UL 943.

11.2 Portable luminaires used in a mount system covered by this standard shall comply with the requirements in the Standard for Portable Electric Luminaires, UL 153. Non-portable luminaires shall comply with the Standard for Luminaires, UL 1598.

11.3 Safety Circuits employing solid-state devices shall comply with the Standard for Tests for Safety-Related Controls Employing Solid-State Devices, UL 991. Mounting systems that incorporate neon lamps shall also comply with the Standard for Neon Transformers and Power Supplies, UL 2161.

11.4 A mount system shall be completely wired with each electrical component mounted in place and with each splice and connection completed or as indicated below:

- a) A detachable power-supply cord may be disconnected from the product, provided it is packaged with the product.
- b) A mounting system that is disassembled for shipping may be provided with mating connectors that are keyed to maintain correct polarity and can be assembled by hand.

## 12 Electrical Enclosures

12.1 A mounting system shall be formed and assembled so that it will have the strength and rigidity necessary to resist the abuses to which it is likely to be subjected, without increasing the risk of fire, electric shock or injury to persons due to total or partial collapse with resulting reduction of spacings, loosening or displacement of parts, or other serious defects.

12.2 For unreinforced, flat surfaces in general, cast metal shall not be less than 1/8 in (3.2 mm) thick, except that malleable iron may be not less than 3/32 in (2.4 mm) and die cast metal may be not less than 5/64 in (2.0 mm) thick. Corresponding thicknesses of not less than 3/32 in, 1/16 in (1.6 mm), and 3/64 in (1.2 mm), respectively, may be acceptable if the surface under consideration is curved, ribbed, or otherwise reinforced, or if the shape or size, or both, of the surface is such that the necessary mechanical strength is provided.

12.3 An enclosure of sheet metal shall be judged with respect to its size, shape, thickness of metal, and its application, considering the intended use of the complete appliance. Sheet steel having a thickness of less than 0.026 in (0.66 mm) if uncoated or 0.029 in (0.74 mm) if galvanized or of nonferrous sheet metal having a thickness of less than 0.036 in (0.91 mm) shall not be used, except for relatively small areas or for surfaces that are curved or otherwise reinforced and tested according to the Electrical enclosure impact test, [65.2](#).

12.4 Sheet metal to which a wiring system is to be connected in the field shall have a thickness not less than 0.032 in (0.81 mm) if uncoated steel, not less than 0.034 in (0.86 mm) if galvanized steel, and not less than 0.045 in (1.16 mm) if nonferrous.

12.5 Among the factors that shall be taken into consideration when judging a nonmetallic enclosure are resistance to:

- a) Mechanical damage;
- b) Impact;