



ULC Standards
Normes ULC



ANSI/CAN/UL/ULC 199:2025A

JOINT CANADA-UNITED STATES
NATIONAL STANDARD

STANDARD FOR SAFETY

Automatic Sprinklers for Fire-Protection Service

ULNORM.COM : Click to view the full PDF of UL 199 2025



ANSI/UL 199-2025



SCC FOREWORD

National Standard of Canada

A National Standard of Canada is a standard developed by a Standards Council of Canada (SCC) accredited Standards Development Organization, in compliance with requirements and guidance set out by SCC. More information on National Standards of Canada can be found at www.scc.ca.

SCC is a Crown corporation within the portfolio of Innovation, Science and Economic Development (ISED) Canada. With the goal of enhancing Canada's economic competitiveness and social well-being, SCC leads and facilitates the development and use of national and international standards. SCC also coordinates Canadian participation in standards development, and identifies strategies to advance Canadian standardization efforts.

Accreditation services are provided by SCC to various customers, including product certifiers, testing laboratories, and standards development organizations. A list of SCC programs and accredited bodies is publicly available at www.scc.ca.

ULNORM.COM : Click to view the full PDF of UL 199 2025

UL Standard for Safety for Automatic Sprinklers for Fire-Protection Service, ANSI/CAN/UL/ULC 199

Thirteenth Edition, Dated February 25, 2022

Summary of Topics

This revision of ANSI/CAN/UL/ULC 199 dated June 27, 2025 includes a correction to the L_m variable definition located in paragraph [17.1.2](#). This was correct in the ballot dated February 5, 2021.

Text that has been changed in any manner or impacted by ULSE's electronic publishing system is marked with a vertical line in the margin.

The corrected requirement is substantially in accordance with Proposal(s) on this subject dated February 5, 2021.

All rights reserved. No part of this publication may be reproduced, stored in a retrieval system, or transmitted in any form by any means, electronic, mechanical photocopying, recording, or otherwise without prior permission of ULSE Inc. (ULSE).

ULSE provides this Standard "as is" without warranty of any kind, either expressed or implied, including but not limited to, the implied warranties of merchantability or fitness for any purpose.

In no event will ULSE be liable for any special, incidental, consequential, indirect or similar damages, including loss of profits, lost savings, loss of data, or any other damages arising out of the use of or the inability to use this Standard, even if ULSE or an authorized ULSE representative has been advised of the possibility of such damage. In no event shall ULSE's liability for any damage ever exceed the price paid for this Standard, regardless of the form of the claim.

Users of the electronic versions of UL's Standards for Safety agree to defend, indemnify, and hold ULSE harmless from and against any loss, expense, liability, damage, claim, or judgment (including reasonable attorney's fees) resulting from any error or deviation introduced while purchaser is storing an electronic Standard on the purchaser's computer system.

No Text on This Page

[ULNORM.COM](https://ulnorm.com) : Click to view the full PDF of UL 199 2025



ANSI/UL 199-2025

FEBRUARY 25, 2022
(Title Page Reprinted: June 27, 2025)



1

ANSI/CAN/UL/ULC 199:2025A

Standard for Automatic Sprinklers for Fire-Protection Service

Fourth Edition – October, 1969
Fifth Edition – May, 1974
Sixth Edition – September, 1977
Seventh Edition – July, 1982
Eighth Edition – February, 1990
Ninth Edition – December, 1995
Tenth Edition – April, 1997
Eleventh Edition – November, 2005
Twelfth Edition – April, 2020

Thirteenth Edition

February 25, 2022

This ANSI/CAN/UL/ULC Safety Standard consists of the Thirteenth Edition including revisions through June 27, 2025.

The most recent designation of ANSI/UL 199 as an American National Standard (ANSI) occurred on February 4, 2025. ANSI approval for this standard does not include the Cover Page, Transmittal Pages, Title Page, Preface or SCC Foreword.

This standard has been designated as a National Standard of Canada (NSC) on February 4, 2025.

© 2025 ULSE Inc. All rights reserved.

No Text on This Page

ULNORM.COM : Click to view the full PDF of UL 199 2025

CONTENTS

Preface 7

INTRODUCTION

1 Scope 11
 2 Components 11
 3 Units of Measurements 11
 4 Normative References 11
 5 Glossary 12
 6 Terminology 15

CONSTRUCTION

7 General 16
 8 Inlet Threads 17
 9 Temperature Ratings 17
 10 Pressure Rating 18
 11 Nominal “K” Factor 18
 12 Coatings And Platings 19
 13 Polymeric Residential Sprinklers 19

PERFORMANCE

GENERAL

14 Details 19
 15 Samples 19

PHYSICAL STRENGTH AND LEAKAGE TESTS

16 Load on Heat Responsive Element Test 19
 17 Strength Of Heat Responsive Element Test 20
 17.1 Fusible-alloy types 20
 17.2 Glass-bulb types 20
 18 Glass-bulb Thermal Shock Test 21
 19 Strength Of Frame Test 21
 20 Impact Resistance Test 21
 21 Impact Test for Protective Covers 23
 22 Impact Test for Guards 25
 23 Rough Usage Test 28
 24 Flow Endurance Test 28
 25 Leakage Test 28
 26 Hydrostatic Strength Test 29
 27 Dry Sprinkler Air Tightness Test 29
 28 30-Day Leakage Test 31
 29 Water Hammer Test 31
 30 Vacuum Test 32

OPERATION TESTS

31 Operating Temperature (Bath) Test 32
 32 Air Bath for Glass Bulb Sprinkler Test 33

33	Sensitivity Tests	33
	33.1 General.....	33
	33.2 Oven heat test.....	34
	33.3 Room heat tests	39
34	Operation – Lodgement Test	47
35	Cycling Tests For Flow Control (FC) Sprinklers	49
	35.1 Operational cycling test.....	49
	35.2 Cycling after water exposure test	50
	35.3 Contaminated-water cycling test	50

EXPOSURE AND CORROSION TESTS

36	High Temperature Exposure Test (90 Day)	50
37	High Temperature Exposure Test for Wax Coated Sprinklers	51
38	High Temperature Exposure Test For Flow Control (FC) Sprinklers	51
39	Heat Resistance Test.....	52
40	Elastomeric Parts Test	52
41	Vibration Test	52
42	Freezing Test	53
43	Evaporation Test for Wax Coatings	53
44	10-Day Corrosion Test	53
	44.1 General.....	53
	44.2 Salt spray exposure	54
	44.3 Moist hydrogen sulfide air mixture	54
	44.4 Moist carbon dioxide-sulfur dioxide air mixture	55
45	30-Day Corrosion Test	55
46	90-Day Moist Air Test.....	55
47	Exposure Tests on Sprinklers Incorporating Polymeric Gaskets	56
	47.1 General.....	56
	47.2 Corrosive exposures	56
	47.3 Temperature cycling exposure	56
	47.4 Hydrocarbon exposure followed by moist air exposure	56
	47.5 Hydrocarbon exposure followed by water immersion exposure.....	56
	47.6 Exposure to antifreeze solutions	57
48	Dry-Type Sprinkler Deposit Loading Test.....	57
49	Dezincification Test of Brass Parts	58
	49.1 General.....	58
	49.2 Reagent.....	58
	49.3 Test pieces	58
	49.4 Method	58
50	Stress-Corrosion Cracking of Brass Sprinkler Parts Test.....	59
51	Stress-Corrosion Cracking Of Stainless Steel Sprinkler Parts Test	59
52	Polymeric Residential Sprinkler Tests	60
	52.1 General.....	60
	52.2 Long-term hydrostatic pressure test	62
	52.3 Temperature cycling test	62
	52.4 Impact test	62

WATER FLOW AND DISTRIBUTION TESTS

53	Discharge Coefficient Test.....	63
54	Water Distribution Tests	66
	54.1 General.....	66
	54.2 Water distribution test – Conventional (old style) sprinklers	67
	54.3 10 Pan distribution test.....	73
	54.4 16 Pan distribution test	74

54.5 100 Pan distribution test – Sidewall sprinklers (standard coverage)77
 54.6 Wall wetting test for ECLH and ECOH sprinklers79
 54.7 Distribution tests for ECOH sprinklers.....80
 54.8 Residential sprinkler water distribution test – Horizontal surface83
 54.9 Residential sprinkler water distribution test – Vertical surface88
 54.10 Distribution tests for pendent ESFR sprinklers having a nominal K-factor of 14.0 or 16.8.....90
 54.11 Thrust force test for pendent ESFR sprinklers having a nominal K-factor of 14.0 or 16.8.....92
 54.12 Lateral discharge tests94

FIRE TESTS

55 Fire Test Requirements95
 55.1 General.....95
 55.2 350 Pound (159 kg) wood crib fire test.....96
 55.3 ECLH sprinkler fire tests102
 55.4 ECOH sprinkler piled stock fire tests.....107
 55.5 Residential sprinkler fire test.....110
 55.6 Flow control (FC) sprinkler piled stock fire tests119
 55.7 CMDA storage sprinkler large scale fire tests123
 55.8 CMSA storage sprinkler large scale fire tests136
 55.9 ESFR sprinkler large scale fire tests144
 55.10 Actual delivered density (ADD) tests for pendent ESFR sprinklers having a nominal K-factor of 14.0 or 16.8.....160
 55.11 Fire tests for specific application sprinklers intended to protect windows.....168
 55.12 Fire tests for specific application sprinklers intended for use in horizontal concealed spaces.....171

MANUFACTURING AND PRODUCTION TESTS

56 General182
 57 Production Leakage Test.....182
 58 Glass Bulb Integrity Test.....182

MARKINGS

59 General183

INSTALLATION INSTRUCTIONS

60 Manufacturer’s Installation Instructions184

ANNEX A (Informative)

A1 TOLERANCE LIMIT CALCULATION METHODS.....187

ANNEX B (Informative)

No Text on This Page

ULNORM.COM : Click to view the full PDF of UL 199 2025

Preface

This is the Thirteenth Edition of ANSI/CAN/UL/ULC 199, Standard for Automatic Sprinklers for Fire-Protection Service.

ULSE is accredited by the American National Standards Institute (ANSI) and the Standards Council of Canada (SCC) as a Standards Development Organization (SDO). ULC Standards is accredited by the Standards Council of Canada (SCC) as a Standards Development Organization (SDO).

This Standard has been developed in compliance with the requirements of ANSI and SCC for accreditation of a Standards Development Organization.

This ANSI/CAN/UL/ULC 199 Standard is under continuous maintenance, whereby each revision is approved in compliance with the requirements of ANSI and SCC for accreditation of a Standards Development Organization. In the event that no revisions are issued for a period of four years from the date of publication, action to revise, reaffirm, or withdraw the standard shall be initiated.

Annexes [A](#) and [B](#), identified as Informative, are for information purposes only.

In Canada, there are two official languages, English and French. All safety warnings must be in French and English. Attention is drawn to the possibility that some Canadian authorities may require additional markings and/or installation instructions to be in both official languages.

This Thirteenth Edition Joint American National Standard and National Standard of Canada is based on, and now supersedes, the Twelfth Edition of UL 199 and the Second Edition of ULC/ORD-C199.

Requests for interpretation of this Standard should be sent to ULC Standards. The requests should be worded in such a manner as to permit a “yes” or “no” answer based on the literal text of the requirement concerned.

Comments or proposals for revisions on any part of the Standard may be submitted at any time. Proposals should be submitted via a Proposal Request in the Collaborative Standards Development System (CSDS) at <https://csds.ul.com>.

Our Standards for Safety are copyrighted by ULSE Inc. Neither a printed nor electronic copy of a Standard should be altered in any way. All of our Standards and all copyrights, ownerships, and rights regarding those Standards shall remain the sole and exclusive property of ULSE Inc.

This Edition of the Standard has been formally approved by the Technical Committee (TC) on Sprinkler Equipment For Fire Protection, TC 199.

This list represents the TC 199 membership when the final text in this standard was balloted. Since that time, changes in the membership may have occurred.

TC 199 Membership

Name	Representing	Interest Category	Region
Kerry M. Bell	UL Solutions	Testing & Stds Org	USA
Art Black	Carmel Fire Protection Associates	Authorities Having Jurisdiction / Regulator	USA
Dale Bonn	Travelers Insurance	General Interest	USA
Chase Browning	National Fire Sprinkler Association	General Interest	USA
Ken Bush	Maryland State Fire Marshal's Office	Authorities Having Jurisdiction	USA
Kevin Hall	American Fire Sprinkler Association	General Interest	USA
Felipe Luz	UL Standards & Engagement	TC Chair	Canada
Rick McCullough	Standards Individuals	General Interest	Canada
Sean Pearce	National Fire Equipment Ltd.	Supply Chain	Canada
Milosh Puchovsky	Worcester Polytechnic Institute	General Interest	USA
Scott Pugsley	Seneca College	General Interest	Canada
Richard Ray	Cybor Fire Protection Co.	Supply Chain	USA
Mohamed Salaheldin	Lichfield Fire & Safety Equipment FZE	Producer	United Arab Emirates
Paul Sasser	Reliable Automatic Sprinkler Co Inc.	Producer	USA
Michael Savage	Marion Country, FL	Authorities Having Jurisdiction	USA
Piya Sawangpanich	P. S GRAND GROUP CO., LTD.	Testing & Stds Org	Thailand
Kevin Scott	KH Scott & Associates	Authorities Having Jurisdiction	USA
David Sheppard	US Bureau of Alcohol Tobacco Firearms & Explosives	Government	USA
Manuel Silva	Johnson Controls Inc.	Producer	USA
Juergen Teschner	Job GMBH	Producer	USA
David Tiller	Office of the Fire Marshal & Emergency Management	Authorities Having Jurisdiction	Ontario
Tom Wancho	Victualic Co.	Producer	USA
Nicolette Weeks	UL Standards & Engagement	TC Project Manager	USA
Jingchuan Zheng	Shenzhen Urban Public Safety and Technology Institute	Testing & Stds Org	China
Jeffrey Zwirn	IDS Research Development Inc.	Producer	USA

International Classification for Standards (ICS): 13.220.01, 13.220.10, 13.220.20

For information on ULSE Standards, visit <http://www.shopulstandards.com>, call toll free 1-888-853-3503 or email us at ClientService@shopULStandards.com.

This Standard is intended to be used for conformity assessment.

The intended primary application of this standard is stated in its scope. It is important to note that it remains the responsibility of the user of the standard to judge its suitability for this particular application.

CETTE NORME NATIONALE DU CANADA EST DISPONIBLE EN VERSIONS FRANÇAISE ET ANGLAISE

ULNORM.COM : Click to view the full PDF of UL 199 2025

No Text on This Page

ULNORM.COM : Click to view the full PDF of UL 199 2025

INTRODUCTION

1 Scope

1.1 These requirements cover automatic sprinklers including conventional, spray, sidewall, extended coverage, residential, certain specific application sprinklers and storage sprinklers including early suppression fast response (ESFR) intended for installation on sprinkler systems for fire-protection service. Requirements for the installation and use of sprinklers are included in the National Building Code of Canada, Standards for the Installation of Sprinkler Systems, NFPA 13; Installation of Sprinkler Systems in One- and Two-Family Dwellings and Manufactured Homes, NFPA 13D; and Installation of Sprinkler Systems in Low-Rise Residential Occupancies, NFPA 13R; as well as other applicable NFPA Standards.

1.2 The requirements in this standard are not intended to restrict the application of representative fire and other tests for special sprinklers, as referenced in Standard for the Installation of Sprinkler Systems, NFPA 13, that are intended to provide protection for specific fire hazards.

2 Components

2.1 Except as indicated in [2.2](#), a component of a product covered by this standard shall comply with the requirements for that component.

2.2 A component is not required to comply with a specific requirement that:

- a) Involves a feature or characteristic not required in the application of the component in the product covered by this standard, or
- b) Is superseded by a requirement in this standard.

2.3 A component shall be used in accordance with its rating established for the intended conditions of use.

2.4 Specific components are incomplete in construction features or restricted in performance capabilities. Such components are intended for use only under limited conditions, such as certain temperatures not exceeding specified limits, and shall be used only under those specific conditions.

3 Units of Measurements

3.1 Where values of measurement are specified in both SI and U.S. Customary units, it is the responsibility of the user of this standard to determine the unit of measurement appropriate for the user's needs.

4 Normative References

4.1 The following standards are referenced in this standard, and portions of these referenced standards may be essential for compliance.

American Society of Mechanical Engineers (ASME) Standards

ANSI/ASME B1.20.1, *Standard on Pipe Threads, General Purpose, Inch*

American Society for Testing and Materials (ASTM) Standards

ASTM B117, *Standard Practice for Operating Salt Spray (Fog) Apparatus*

ASTM E11, *Standard Specification for Woven Wire Test Sieve Cloth and Test Sieves*

ASTM E1354, *Test Method for Heat and Visible Smoke Release Rates for Materials and Products Using an Oxygen Consumption Calorimeter*

National Fire Protection Association (NFPA) Codes and Standards

NFPA 13, *Standard for the Installation of Sprinkler Systems*

NFPA 13D, *Standard for the Installation of Sprinkler Systems in One- and Two-Family Dwellings and Manufactured Homes*

NFPA 13R, *Standard for the Installation of Sprinkler Systems in Low-Rise Residential Occupancies*

NFPA 30, *Flammable and Combustible Liquids Code*

NFPA 30B, *Code for the Manufacture and Storage of Aerosol Products*

National Research Council Canada

National Building Code of Canada

UL Standards

UL 9, *Standard for Fire Tests of Window Assemblies*

UL 157, *Standard for Gaskets and Seals*

UL 723, *Standard for Test for Surface Burning Characteristics of Building Materials*

UL 746C, *Standard for Polymeric Materials – Use in Electrical Equipment Evaluations*

ULC Standards

CAN/ULC-S102, *Method of Test for Surface Burning Characteristics of Building Materials and Assemblies*

CAN/ULC-S136, *Standard Method of Fire Test of Sprinkler Protected Window Systems*

5 Glossary

5.1 For the purpose of this standard the following definitions apply:

5.2 **ACTUAL DELIVERED DENSITY (ADD)** – The rate at which water, discharged from a sprinkler, is actually deposited onto the top of the protected horizontal surface under a fire condition.

5.3 **ASSEMBLY LOAD** – The extension force applied to the sprinkler frame by the assembly of its operating mechanism.

5.4 **AUTOMATIC SPRINKLER** – A sprinkler intended to open automatically by operation of a heat-responsive element that maintains the discharge orifice closed by means such as the exertion of pressure on a cap (button or disc). A sprinkler is installed on piping so that a spray of water is discharged in a specific pattern for suppression or control of fires.

5.5 CEILING SPRINKLER – See Concealed Ceiling Sprinkler (5.7), Flush Ceiling Sprinkler (5.18) and Recessed Ceiling Sprinkler (5.28).

5.6 COATED, PAINTED, OR PLATED SPRINKLER – A sprinkler that has factory applied coatings, paint, or platings for corrosion protection or decorative purposes.

5.7 CONCEALED CEILING SPRINKLER – A sprinkler assembly having a cover plate.

5.8 CONTROL MODE DENSITY AREA (CMDA) STORAGE SPRINKLER FOR STANDARD COVERAGE AREAS – A sprinkler intended to be installed using standard coverage areas and density/area criteria referenced in NFPA 13.

5.9 CONTROL MODE SPECIFIC APPLICATION (CMSA) STORAGE SPRINKLER – A sprinkler intended for the protection of stored commodities as referenced in NFPA 13 or the end use limitations specified for the product.

5.10 CONVENTIONAL (OLD STYLE) SPRINKLER – A sprinkler intended for installation in the upright or pendent position, that directs from 40 to 60 % of the total water initially discharged in the downward direction.

5.11 DISCHARGE COEFFICIENT "K" – Coefficient of discharge in the formula,

$$K = \frac{Q}{\sqrt{P}}$$

in which:

Q is the flow in gpm, and

p is the pressure in lbf/in² gauge (psig).

In SI units:

Q is the flow in l/min; and

p is the pressure in bar.

5.12 DRY-TYPE SPRINKLER – A sprinkler secured in an extension nipple that has a seal at the inlet end to prevent water from entering the nipple until the sprinkler operates. These sprinklers consist of an upright, pendent, sidewall, flush, or other types.

Note: Dry-type ESFR sprinklers are intended for use on wet systems only since ESFR sprinklers are not intended for use in dry systems as referenced in NFPA 13.

5.13 EARLY-SUPPRESSION FAST-RESPONSE (ESFR) SPRINKLER – A quick responding sprinkler that automatically discharges water over a specified area to provide early suppression of a fire.

5.14 EXTENDED COVERAGE SPRINKLER INTENDED FOR LIGHT HAZARD OCCUPANCIES (ECLH) – A sprinkler having a specified area of coverage which is larger than the standard sprinkler coverage areas and is intended for use in light hazard occupancies described in NFPA 13.

5.15 EXTENDED COVERAGE SPRINKLER INTENDED FOR ORDINARY HAZARD OCCUPANCIES (EOH) – A sprinkler having a specified area of coverage which is larger than the standard sprinkler coverage areas and is intended for use in ordinary hazard occupancies described in NFPA 13.

5.16 EXTENDED COVERAGE CONTROL MODE DENSITY AREA (CMDA) STORAGE SPRINKLER – A sprinkler intended to be installed using the extended coverage area and density/area criteria referenced in NFPA 13.

5.17 FLOW CONTROL (FC) SPRINKLER – A sprinkler that is intended to control water flow by automatically cycling open and closed within a specified temperature range.

5.18 FLUSH CEILING SPRINKLER – A sprinkler in which all or part of the body is mounted above the lower plane of the ceiling (or beyond a wall for sidewall sprinklers), but all of the heat responsive collector is below the lower plane of the ceiling (or beyond a wall for sidewall sprinklers).

5.19 HEAT RESPONSIVE ELEMENT – That portion of a sprinkler that breaks, melts, or otherwise functions to initiate the automatic operation of the sprinkler when exposed to sufficient heat.

5.20 HEPTANE – Commercial grade heptane having the following characteristics:

- a) Minimum Initial Boiling Point of 190 °F (88 °C);
- b) Maximum Dry Point of 212 °F (100 °C); and
- c) Specific Gravity (60 °F/60 °F) (15.6 °C/15.6 °C) of 0.68 – 0.73.

5.21 OPEN SPRINKLER – An automatic sprinkler with the heat responsive and activating elements removed. The discharge orifice is open.

5.22 OPERATING TEMPERATURE – The temperature at which the heat responsive element of a sprinkler operates when immersed in a liquid bath under controlled rate of rise conditions.

5.23 ORIFICE – The opening that controls the amount of water discharged from a sprinkler at a given pressure.

5.24 PENDENT SPRINKLER – A sprinkler intended to be installed so that its deflector is located below the orifice and the water flows downward against the deflector.

5.25 QUICK RESPONSE-EXTENDED COVERAGE LIGHT HAZARD OCCUPANCY SPRINKLER – A sprinkler that complies with the applicable requirements for such sprinklers in the Sensitivity Tests, Section [33](#), when tested and installed in a test room at greater than standard spacings as stated in the installation instructions and complies with the requirements for extended coverage light hazard occupancy sprinklers.

5.26 QUICK RESPONSE-EXTENDED COVERAGE ORDINARY HAZARD OCCUPANCY SPRINKLER – A sprinkler that complies with the applicable requirements for such sprinklers in the Sensitivity Tests, Section [33](#), when tested and installed in a test room at greater than standard spacings as stated in the installation instructions and complies with the requirements for extended coverage ordinary hazard occupancy sprinklers.

5.27 QUICK RESPONSE (QR) SPRINKLER – A sprinkler that complies with the applicable requirements for such sprinklers in the Sensitivity Tests, Section [33](#), and that is intended to be installed at standard spacings.

5.28 RECESSED CEILING SPRINKLER – A sprinkler assembly in which all or part of the sprinkler body or frame, other than the inlet thread, is mounted within a recessed housing.

5.29 RESIDENTIAL SPRINKLER – A sprinkler intended to be installed in residential occupancies.

5.30 RESPONSE TIME INDEX (RTI) – A measure of the thermal sensitivity of the sprinkler's heat responsive element.

5.31 SIDEWALL SPRAY SPRINKLER – A sprinkler intended for installation on or near the wall and near the ceiling, and designed to discharge most of the water away from the nearby wall with a small portion of the discharge directed at the wall behind the sprinkler.

5.32 SPECIFIC APPLICATION SPRINKLERS – A sprinkler intended for a limited end use such as for protecting windows, combustible concealed spaces or attics.

5.33 SPRAY SPRINKLER (STANDARD) – A sprinkler intended for installation in either the upright or pendent position respectively, designed to distribute water downward in an umbrella-shaped pattern. The discharge from a spray sprinkler having a nominal 5.6 (80) "K" factor covers a circle 16 ft (4.88 m) in diameter, 4 ft (1.22 m) below the sprinkler, when the sprinkler is discharging water at the rate of 15 gpm (57 l/min). See 10 Pan Distribution Test, [54.3](#).

5.34 STANDARD FIRE TEST COMMODITY – CARTONED GROUP A PLASTICS (UNEXPANDED) – Single wall corrugated cardboard cartons measuring a nominal 21 by 21 by 20.5 in high (530 by 530 by 520 mm) containing 125 crystalline polystyrene cups in separate compartments within the carton. Single wall corrugated cardboard sheets are used to separate the five layers of cups and interlocking single wall corrugated cardboard vertical dividers are used to separate the 25 cups in each layer. Eight of the cartons are arranged in a 2 x 2 x 2 array with the open end of the cups facing down and placed on a nominal 42 by 42 by 5 in high (1070 by 1070 by 127 mm) two-way hardwood pallet.

5.35 STANDARD FIRE TEST COMMODITY – CLASS II Double tri-wall corrugated cardboard cartons with five-sided steel (open bottom) stiffeners inserted for stability. The cartons are to comply with the requirements for Class 2, Style E, "AAA" fluting as specified in the Federal Specification for Boxes, Fiberboard, Corrugated, Tri-Wall, PPP-B-640D. The two cartons have a combined nominal thickness of 1 in (25 mm). The nominal measurements for the outside carton are 42 by 42 by 42 in (1070 by 1070 by 1070 mm) and the nominal measurements for the inside carton are 41 by 41 by 41 in (1040 by 1040 by 1040 mm). The cartons are to be placed on a nominal 42 by 42 by 5 in high (1070 by 1070 by 127 mm) two-way hardwood pallet.

5.36 STORAGE SPRINKLER – See Control Mode Density Area (CMDA) Storage Sprinkler for Standard Coverage Areas (See [5.8](#)), Control Mode Specific Application (CMSA) Storage Sprinkler ([5.9](#)), Early-Suppression Fast-Response (ESFR) Sprinkler ([5.13](#)) and Extended Coverage Control Mode Density Area (CMDA) Storage Sprinkler ([5.16](#)).

5.37 UPRIGHT SPRINKLER – A sprinkler intended to be installed so that its deflector is located above the orifice and the water flows upward against the deflector.

6 Terminology

6.1 Where these requirements reference "automatic sprinkler", the requirements apply to any type of sprinkler unless otherwise specified.

6.2 Where these requirements reference "extended coverage sprinklers", the requirements apply to any type of extended coverage sprinkler unless otherwise specified.

CONSTRUCTION

7 General

7.1 An automatic sprinkler shall be constructed to effect closure of its water seat for extended periods of time without leakage and to open as intended and release all parts as specified in this standard. The closure of the water seat shall not be achieved by the use of a dynamic O-ring or similar seal (an O-ring or similar seal that moves during operation or is in contact with a component that moves during operation).

7.2 For dry-type pendent and sidewall sprinklers, the connection of the extension nipple to the seal assembly at the inlet shall be airtight. See Dry Sprinkler Air Tightness Test, Section [27](#).

7.3 Stampings shall show no cracking or splitting and shall be uniformly smooth and clean cut.

7.4 An automatic sprinkler shall be chemically or mechanically staked to maintain the manufacturer's assembly load. The assembly load shall not be able to be changed by the use of common hand tools without causing visible damage to the sprinkler.

7.5 Sprinkler types or materials not anticipated by these requirements require additional evaluation, such as tests to investigate special metallic or nonmetallic materials.

7.6 An escutcheon for sprinklers other than the polymeric residential sprinklers shall be constructed of a metallic material.

7.7 When installed with the intended fittings specified in the installation instructions, see Manufacturer's Installation Instructions, Section [60](#), dry sprinklers installed in dry systems shall be constructed to minimize the potential to accumulate water, scale, and sediment on the sprinkler inlet and shall provide an unobstructed flow path upon operation.

7.8 For sprinklers incorporating a glass bulb heat responsive element, the filling end tip of the bulb shall be completely encased in an enclosure to minimize the potential for breakage or damage. For the purposes of applying this requirement, a bulb tip within the waterway of a dry type sprinkler shall be considered enclosed.

7.9 Sprinklers with glass bulb type heat responsive elements shall be equipped with protective covers that are designed to remain in place during installation and be removed before the sprinkler system is placed in service.

Exception: Certain sprinkler designs, such as sprinklers with guards, concealed, intermediate level, wax coated and dry type sprinklers, may not be required to have protective covers.

7.10 Sprinklers required to be equipped with sprinkler covers shall comply with Impact Test for Protective Covers, Section [21](#) and [59.12](#).

7.11 In addition to the applicable requirements described herein, flexible dry-type sprinklers or sprinklers constructed with an integral flexible hose connection shall be evaluated in accordance with the applicable requirements described in UL 2443, Standard for Flexible Sprinkler Hose with Fittings for Fire Protection Service. Sprinklers with an integral flexible hose connection shall be constructed to avoid the potential of altering the K-factor of the assembly when the sprinkler needs to be replaced, such as having an inlet configuration that is not typical for the K-Factor of the assembly.

8 Inlet Threads

8.1 Sprinklers shall be provided with external pipe threads at the inlet end as specified in [Table 11.1](#). Inlet-end pipe threads shall comply with the Standard on Pipe Threads, General Purpose, Inch, ANSI/ASME B1.20.1.

Exception No. 1: Dry-type sprinklers shall be permitted to be provided with larger external NPT pipe threads.

Exception No. 1A: External taper pipe threads (NPT) of 1-in size shall be permitted to be used for 5.6 and 8.0 nominal “K” factor sprinklers in lieu of those specified in [Table 11.1](#).

Exception No. 2: Internal taper pipe threads (NPT) of 3/4- or 1-in size shall be permitted to be used for an 8.0 nominal “K” factor, ceiling, and dry type sprinklers in lieu of those specified in [Table 11.1](#).

Exception No. 3: Sprinklers intended for use in installations where sprinkler fittings incorporate pipe threads other than NPT type threads shall be permitted to be provided with pipe threads complying with a national pipe thread standard compatible with those fittings.

Exception No. 4: Sprinkler inlets intended for attachment to piping by means other than threads are able to be used when the sprinklers:

- a) Have a nominal “K” factor corresponding to the discharge coefficient as specified in [Table 11.1](#);*
- b) Are provided with nominal “K” factor markings as specified in [59.2](#); and*
- c) Are intended to be attached in a manner that does not involve welding and that permits sprinkler removal from sprinkler piping without the use of special tools or torch cutting equipment.*

8.2 Threads shall be clean cut and true and free from burrs, scoring, or chatter marks.

9 Temperature Ratings

9.1 The temperature ratings, temperature classifications, and color codings of automatic sprinklers shall be as specified in [Table 9.1](#). See [59.6](#).

**Table 9.1
Temperature Ratings, Classifications, and Color Codings**

Temperature classification	Temperature rating		Color code		Maximum ceiling temperature	
	°F	(°C)	Sprinkler	Glass bulb	°F	(°C)
Ordinary	135 – 170	(57 – 77)	Uncolored or Black	Orange – 135 °F (57 °C) Red – 155 °F (68 °C)	100	(38)
Intermediate	175 – 225	(79 – 107)	White	Yellow – 175 °F (79 °C) Green – 200 °F (93 °C)	150	(66)
High	250 – 300	(121 – 149)	Blue	Blue	225	(107)
Extra high	325 – 375	(163 – 191)	Red	Purple	300	(149)
Very extra high	400 – 475	(204 – 246)	Green	Black	375	(191)
Ultra high	500 – 575	(260 – 302)	Orange	Black	475	(246)

9.2 Residential and ESFR sprinklers shall have a temperature rating that falls within the range of the ordinary or intermediate classification.

10 Pressure Rating

10.1 Sprinklers other than storage and ESFR sprinklers shall have a rated pressure of 175 psig (1.2 Mpa), 250 psig (1.7 Mpa), or 300 psig (2.1 Mpa). Storage and ESFR sprinklers shall have a rated pressure of 175 psig (1.2 Mpa).

10.2 The discharge pressure associated with a rated flow for any sprinkler shall not be less than 7 psig (48 kPa).

11 Nominal “K” Factor

11.1 Sprinklers other than residential sprinklers and dry sprinklers in lengths longer than the minimum, shall have a discharge coefficient complying with one of the nominal “K” factor ranges specified in [Table 11.1](#). The nominal “K” factor is to be determined from the discharge coefficient “K”, as specified by the Discharge Coefficient Test, Section [53](#).

Table 11.1
Nominal “K” factor and thread size

Nominal K-factor, gpm/(psi) ^{1/2} (L/min/(bar) ^{1/2})	Discharge coefficient “K”		External thread-type in NPT
	gpm/(psi) ^{1/2}	(L/min/(bar) ^{1/2})	
1.4 (20)	1.3 – 1.5	(19 – 22)	1/2
1.9 (27)	1.8 – 2.0	(26 – 29)	1/2
2.8 (40)	2.6 – 2.9	(38 – 42)	1/2
4.2 (60)	4.0 – 4.4	(57 – 63)	1/2
5.6 (80)	5.3 – 5.8	(76 – 84)	1/2
8.0 (115)	7.4 – 8.2	(107 – 118)	3/4 or 1/2*
11.2 (160)	10.7 – 11.7	(159 – 166)	3/4 or 1/2*
14.0 (200)	13.5 – 14.5	(195 – 209)	3/4
16.8 (240)	16.0 – 17.6	(231 – 254)	3/4
19.6 (280)	18.6 – 20.6	(272 – 301)	1
22.4 (320)	21.3 – 23.5	(311 – 343)	1
25.2 (360)	23.9 – 26.5	(349 – 387)	1
28.0 (400)	26.6 – 29.4	(389 – 430)	1

* The 1/2 in NPT inlet thread for these sprinklers are for use in existing facilities (retrofit) only as referenced in NFPA 13.

11.2 The diameter of a discharge orifice or any internal passage of a sprinkler shall be at least 0.21 in (5.3 mm).

11.3 Sprinklers intended for use in dry or pre-action systems shall have a “K” factor greater than 4.0.

12 Coatings And Platings

12.1 The operation and distribution characteristics of a sprinkler shall not be impaired by the application of any factory applied coating, paint, or plating when the sprinkler is tested in accordance with these requirements.

12.2 A corrosion resistant coating or plating shall be uniformly applied.

12.3 A wax coating shall not be brittle when new nor become brittle with age.

13 Polymeric Residential Sprinklers

13.1 Residential sprinklers having pressure retaining and other load bearing components made of polymeric materials shall be constructed to comply with the following:

- a) Requirements described within this standard that are applicable to residential sprinklers.
- b) Sprinklers that have polymeric gaskets and no additional pressure retaining or load bearing polymeric components are not limited to the use restrictions described in [13.2](#) and [13.3](#).

13.2 Polymeric materials used to construct pressure retaining and load bearing components shall be constructed in such a manner that the polymeric materials do not extend into the area being protected by the sprinkler unless covered with a metallic material such as brass, bronze or stainless steel.

13.3 The manufacturer's installation instructions shall indicate that the polymeric sprinklers are to be attached to plastic sprinkler pipe and fittings only. See Section [60](#).

PERFORMANCE

GENERAL

14 Details

14.1 To determine compliance with these requirements, the various types and patterns of a sprinkler shall be subjected to the applicable performance tests described herein.

14.2 When a recessed or concealed sprinkler is tested with an escutcheon and cover plate (as applicable) during the performance tests, the sprinkler is to be recessed to the maximum depth allowed by the sprinkler/escutcheon combination.

15 Samples

15.1 The number of samples required for investigation varies for different sprinkler types. The number of samples required for examination and test are to be determined following a review of detailed drawings, examination of a preliminary sample, or both.

PHYSICAL STRENGTH AND LEAKAGE TESTS

16 Load on Heat Responsive Element Test

16.1 The average and maximum design loads exerted on the heat responsive element, and the overall load tolerance based on the design load for the assembly, are to be determined. When the application of the rated working pressure to the inlet end of the sprinkler increases the assembly load by more than

10 %, the additional load is to be added to the measured load on the heat responsive element. The information developed is to be used for Strength of Heat Responsive Element Test, Section [17](#).

16.2 At least 25 sprinklers are to be tested to determine the average load. An arrangement for measuring the load on the heat responsive element is to be developed for each specific design.

17 Strength Of Heat Responsive Element Test

17.1 Fusible-alloy types

17.1.1 A heat responsive element in the ordinary temperature rating shall either:

- a) Sustain a load of 15 times its maximum design load for a period of 100 h; or
- b) Demonstrate the ability to sustain the maximum design load when tested in accordance with [17.1.2](#) and [17.1.3](#).

17.1.2 Compliance with [17.1.1\(a\)](#) is to be determined by subjecting at least ten sample heat responsive elements to a load of 15 times the maximum design load for at least 100 h. Compliance with [17.1.1\(b\)](#) is to be determined by subjecting sample heat-responsive elements to loads in excess of the maximum design load. A minimum of ten samples are to be loaded at various values as required up to 15 times the design load. At least one heat responsive element shall sustain a load for a time greater than 1000 h. These load and time values shall then be used to derive a least-square, full logarithmic regression curve of load as a function of time, from which the loads at 1 h and 1000 h are to be determined. The design load shall comply with the following equation:

$$L_d \leq 1.02 L_m^2 / L_o$$

in which:

L_d is the maximum design load;

L_m is the load at 1000 h; and

L_o is the load at 1 h.

17.1.3 The test samples are to be loaded at a conditioned temperature of 70 ± 5 °F (21 ± 3 °C).

17.2 Glass-bulb types

17.2.1 The lower tolerance limit for bulb strength, based on calculations with a degree of confidence of 0.99 for 99 % of samples, shall exceed two times the upper tolerance limit for sprinkler assembly load based on calculations with the same degree of precision as for bulb strength.

17.2.2 The bulb strength is to be measured by applying a steadily increasing load, utilizing a compression testing machine, until the bulb breaks. This test is to be conducted with the bulb mounted in the seating parts, with the same dimensions used in the sprinkler and a material hardness within the range of 38 – 50 Rockwell C. The rate of loading shall not exceed 55 lbf load per s (25 kg/s), or at a rate that deflects the bulb 0.02 in (0.51 mm) per min, whichever measurement is convenient for the test apparatus being used. Bulb seats shall be permitted to be reinforced circumferentially to not interfere with the bulb breakage. A minimum of 15 samples of each temperature rating and each bulb type are to be tested. See Annex [A](#).

17.2.3 Calculations are to be based on the Normal or Gaussian Distribution except where another distribution is shown to be more applicable due to manufacturing or design factors.

18 Glass-bulb Thermal Shock Test

18.1 A sprinkler having a glass bulb shall withstand the thermal shock of rapid temperature changes without breakage or fracture of the glass bulb when tested as specified in [18.2](#).

18.2 At least five samples of the sprinkler are to be conditioned for 5 min in a liquid bath at 20 °F (11 °C) less than the marked temperature rating. The samples then are to be removed and immediately submerged in another liquid bath at 50 °F (10 °C). The bulb of each sprinkler shall be visually observed for signs of breakage or fracture.

19 Strength Of Frame Test

19.1 An automatic sprinkler frame shall not show permanent deformation in excess of 0.2 % of the distance between its bearing points when subjected to a test loading of twice its assembly load at rated hydrostatic pressure.

19.2 The distance between load-bearing points is to be measured to the nearest 0.001 in (0.03 mm) from the plane of the sprinkler-orifice outlet at the center of the orifice to the center of the compression bearing surface.

19.3 At least ten sprinkler samples are to be individually installed in a test apparatus that applies a load to the upper compression bearing surface. A measuring instrument is to be attached to indicate the amount of deflection at the deflector end of the sprinkler frame.

19.4 With the threaded inlet restrained from movement, a measuring instrument is to be positioned to indicate the amount of deflection at the deflector end of the sprinkler frame. The heat responsive element of the sample is then to be carefully removed so as not to damage the frame. The negative axial deflection, due to release of the assembly load, is to be recorded. A force is then to be applied to re-deflect the sprinkler at a rate of 0.02 in (0.51 mm) per min until the deflection returns to zero. The force at zero deflection is to be recorded as the assembly load. An alternate means of determining assembly load shall be permitted to be utilized when determined to provide equivalent or more accurate results.

19.5 A force equal to twice the sum of the force recorded in [19.4](#) plus the force applied to the sprinkler frame at rated pressure is then to be applied to each sample and held for not more than 5 s. The deflection during the application of this load and the amount of permanent set after the load has been released are to be determined. The percentage of permanent deformation (elongation) shall be calculated using the measured permanent deflection and the minimum distance measured between load bearing points to verify compliance with the requirements in [19.1](#).

20 Impact Resistance Test

20.1 An automatic sprinkler, except for dry type sprinklers, shall not be damaged or leak when tested as described in [20.2](#). See [Figure 20.1](#).

20.2 Five sample sprinklers are to be tested by dropping a cylindrical mass equivalent to the mass of the sprinkler to the nearest 15 g increment from a height of one meter onto the geometric center of the deflector, or when this is not practicable such as with a concealed or flush type sprinkler, onto the butt end of the sprinkler. The mass is to be prevented from impacting more than once upon each sample. Following the impact, each sprinkler is to be visually examined and there shall be no evidence of cracks, breaks, or any other damage. Each sample sprinkler shall then be subjected to the Leakage Test, Section [25](#), followed by the applicable testing in Sensitivity Tests, Section [33](#) based upon sprinkler type.

Figure 20.1
Impact test apparatus

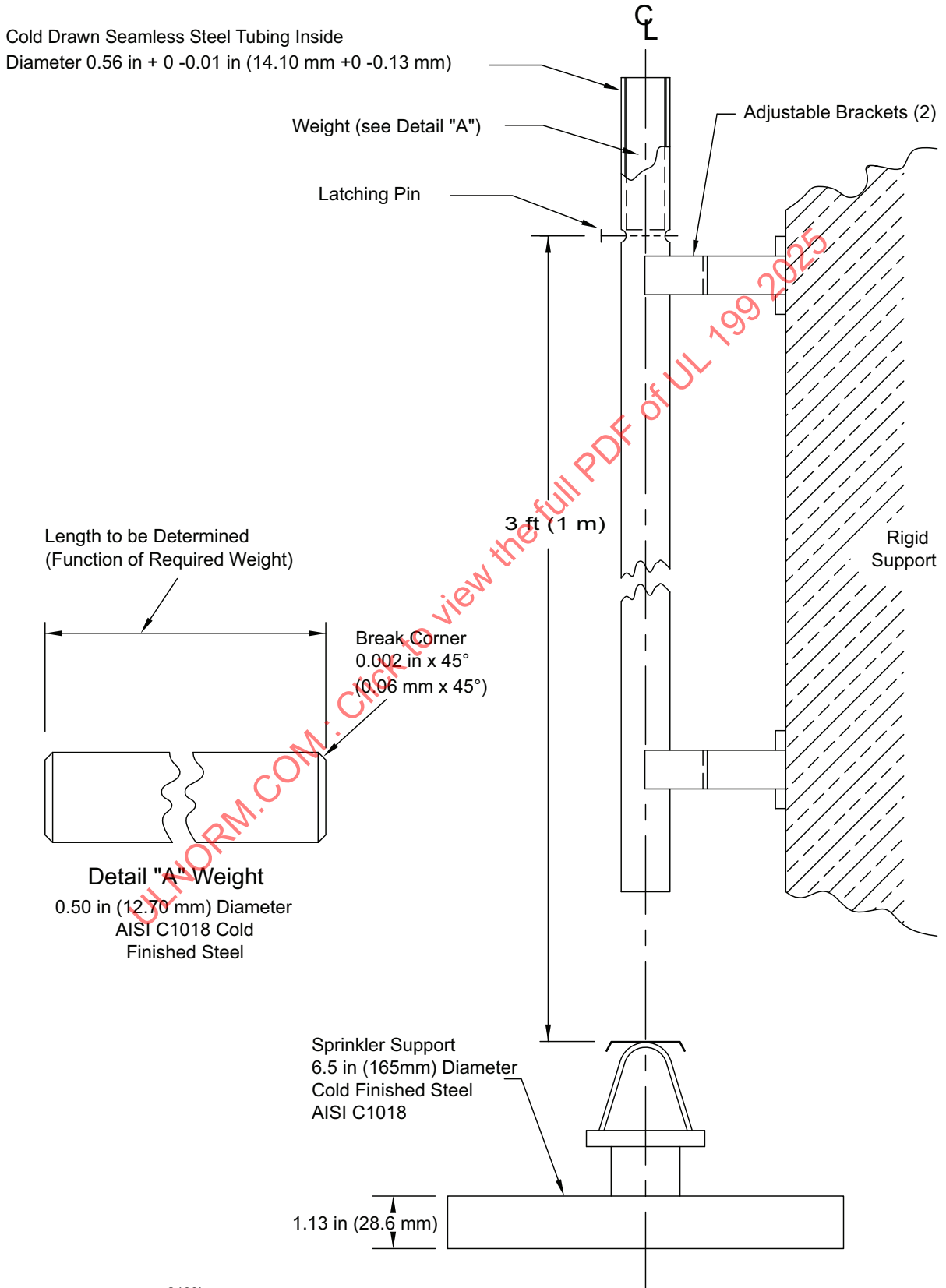

21 Impact Test for Protective Covers

21.1 A glass bulb type sprinkler, with the protective cover installed, shall not be damaged or leak and the cover shall remain in place when tested as described in [21.2](#). See [Figure 21.1](#).

ULNORM.COM : Click to view the full PDF of UL 199 2025

Figure 21.1
Impact test apparatus for protective covers

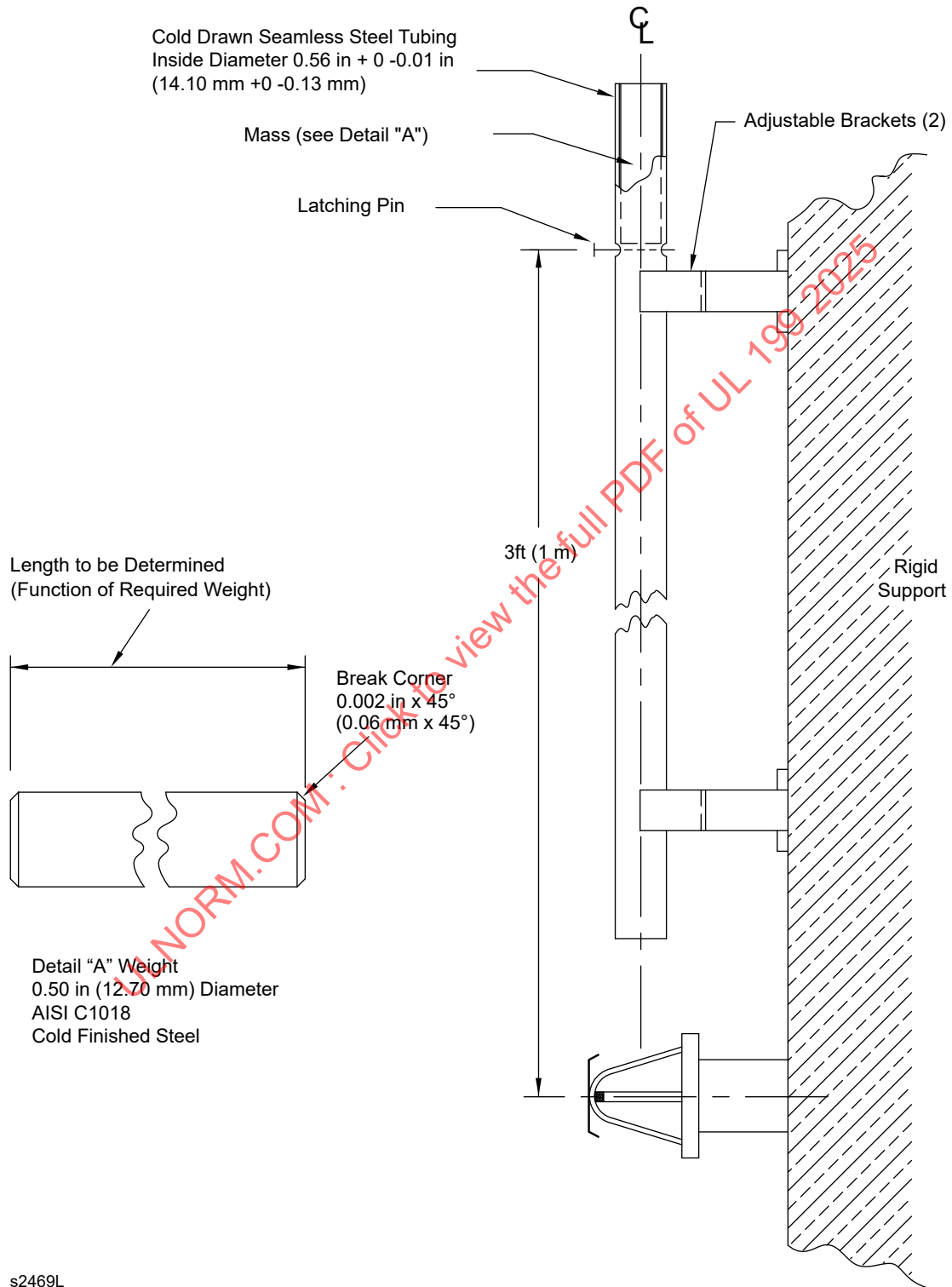

21.2 Five sample glass bulb sprinklers with their protective covers are to be mounted in the horizontal position and impacted with a cylindrical mass equivalent to the mass of the sprinkler to the nearest 15 g increment from a height of one meter onto the geometric center of the glass heat responsive element. Five additional samples are to be tested with the impact applied to the opposite side of the sprinkler if the cover is designed to provide unsymmetrical protection. If the glass bulb extends beyond the perimeter of the sprinkler deflector, an additional five sample sprinklers are to be mounted in the vertical position and impacted with the same cylindrical mass from a height of one meter onto the geometric center of the glass heat responsive element. The mass is to be prevented from impacting more than once upon each sample. Following the impact, each sprinkler is to be visually examined and there shall be no evidence of cracks, breaks, or any other damage to the glass bulb. Each sample sprinkler shall then be subjected to the Leakage Test, Section [25](#). In addition, each sample shall then be subjected to the applicable testing in Sensitivity Tests, Section [33](#) based upon sprinkler type.

22 Impact Test for Guards

22.1 Sprinkler and guard assemblies subjected to the tests described in [22.2](#) – [22.5](#), shall:

- a) Show no evidence of visual damage to the sprinkler; and
- b) Comply with the Operation – Lodgement Test, Section [34](#).

22.2 Twelve sample sprinklers are to be assembled with their intended guard in accordance with the manufacturers installation instructions and divided into two groups of six assemblies in each group.

22.3 Samples from the first group are to be tested individually by dropping a 1.18 lb (0.54 kg), 2 in (50.8 mm) in diameter stainless steel ball (Series 440) from a height of 2.5 ft (0.76 m) onto the end of the assembly as shown in [Figure 22.1](#). Samples from the second group are to be tested individually by dropping the ball onto the side, near the top of the guard as shown in [Figure 22.2](#).

ULNORM.COM : Click to view the full PDF of UL 199-2025

Figure 22.1
Impact test on first group of samples

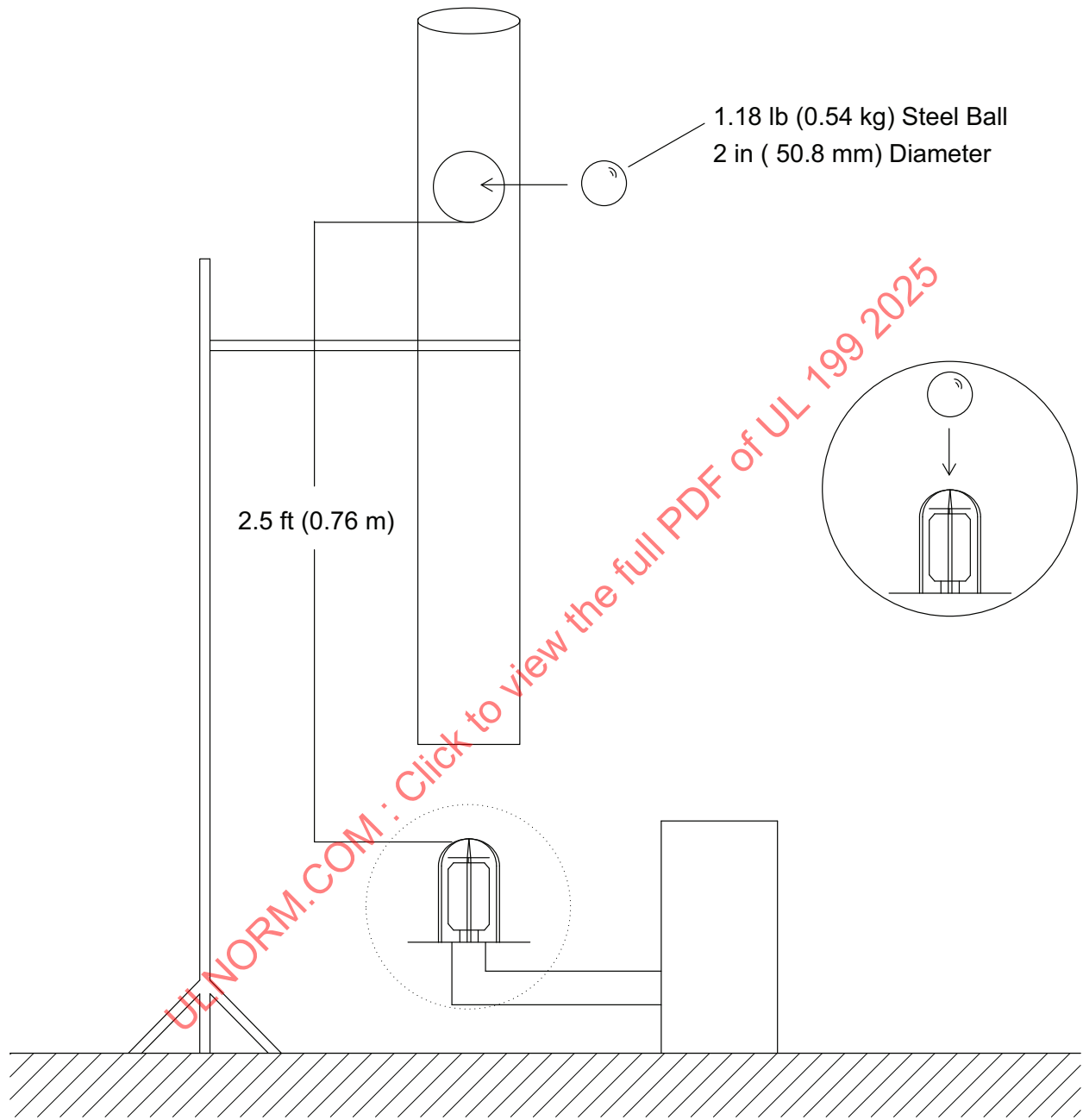

sm1184b

Figure 22.2
Impact test on second group of samples

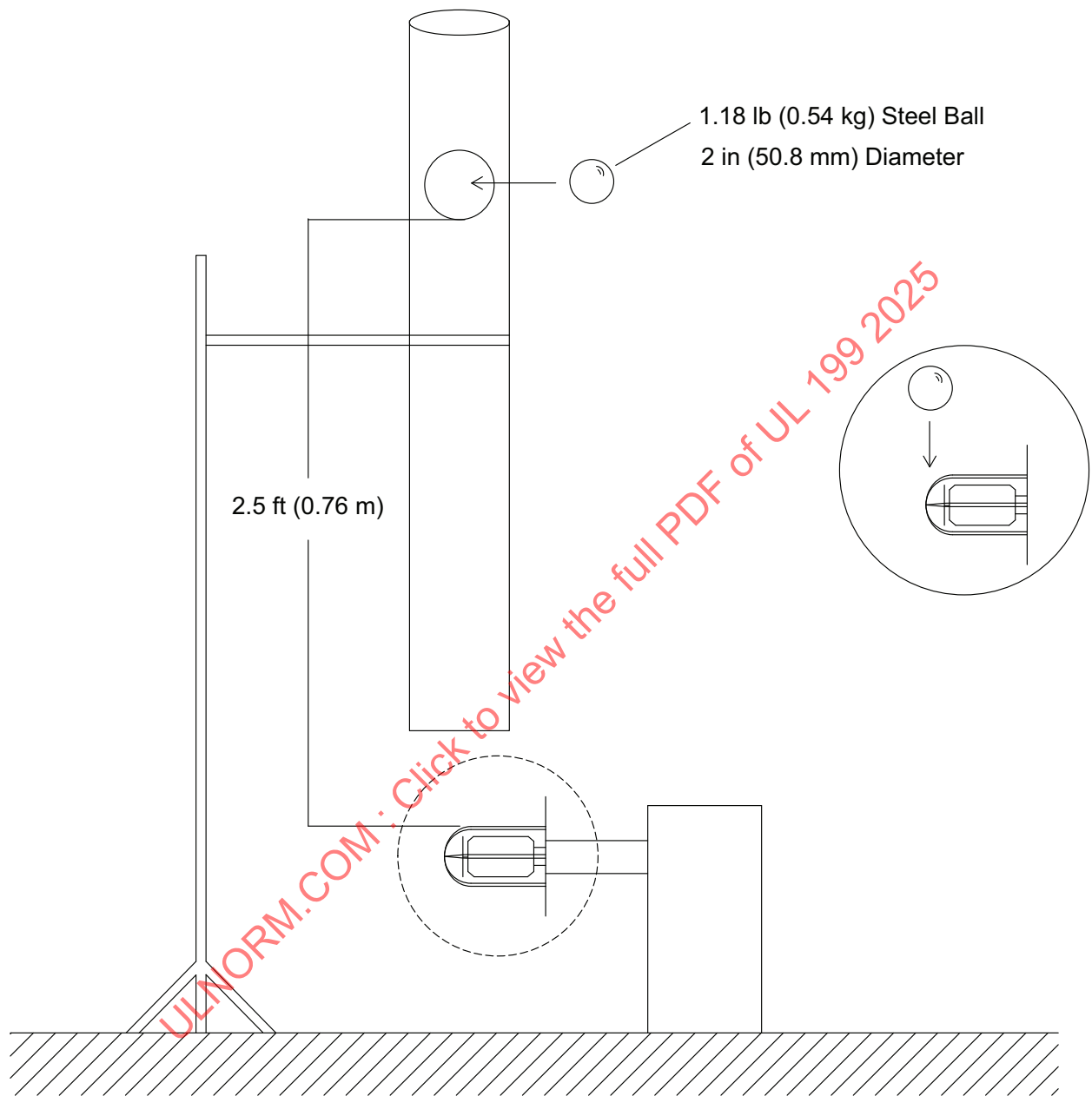

sm1185b

22.4 Impact due to falling steel ball in both cases shall be located between support members of the guard.

22.5 After impact, the sprinkler samples shall be visually examined for damage. The samples are then subjected to the Operation – Lodgement Test, Section 34 except that one sample from each group is to be tested using the double feed arrangement at each of following inlet six pressures: 25 (172), 50 (345), 75 (517), 100 (689), 125 (862) and 150 (1206) psig (kPa).

23 Rough Usage Test

23.1 An automatic sprinkler, except for dry-type sprinklers, shall withstand the effects of rough usage without deterioration of its performance characteristics. Following 3 min of tumbling as described in 23.3, the sprinkler shall comply with the Leakage Test, Section 25, and the Sensitivity Tests, Section 33 based upon the sprinkler type.

23.2 Five sample sprinklers are to be tested. The sprinklers are to be tested with a shipping protector in place when the protector is intended to be removed from the sprinkler after the sprinkler is installed and reference to this removal requirement is made in the installation instructions.

23.3 Five samples are to be individually placed in a vinyl-lined right hexagonal prism-shaped drum^a designed to provide a tumbling action. The drum is to have an axis of rotation of 10 in (254 mm). The distance between opposite sides is to be 12 in (305 mm). For each test, one sample and five 1-1/2-in (38.1-mm) hardwood cubes are to be placed in the drum. The drum is to be rotated at 1 revolution per s for 3 min. The sample is to be removed from the drum, examined for signs of damage, and then subjected to the Leakage Test, Section 25, and to the Sensitivity Tests, Section 33.

^a A drum acceptable for this test is available from Kramer Industries, Inc., Copiague, NY 11726, Model K1401.

24 Flow Endurance Test

24.1 An automatic sprinkler shall withstand for 30 min, without evidence of cracking, deformation, or separation of any part, a waterflow at a pressure equal to the rated pressure plus 25 psig (172 kPa).

24.2 One sample of an automatic sprinkler is to be installed in its intended installation orientation on an elbow or tee for dry type sprinklers in a pressurized water system having a supply pipe with a minimum nominal diameter of 1-1/2 in (40 mm). For concealed type sprinklers, the deflector support pins shall be orientated parallel to the supply pipe. The heat responsive element of the sprinkler is to be activated at the specified test pressure, and the water flow shall be adjusted to obtain the specified test pressure for 30 min.

25 Leakage Test

25.1 When tested as described in 25.2 and 25.3, an automatic sprinkler shall not exhibit leakage at any pressure from 0 to the applicable leakage test pressure shown in Table 25.1.

**Table 25.1
Test Pressures for the Leakage and Hydrostatic Tests**

Rated pressure		Leakage test pressure		Hydrostatic test pressure	
psig	(MPa)	psig	(MPa)	psig	(MPa)
175	(1.2)	500	(3.4)	700	(4.8)
250	(1.7)	500	(3.4)	1000	(6.9)
300	(2.1)	600	(4.1)	1200	(8.3)

25.2 At least 20 samples are to be individually tested. The sprinkler inlets are to be filled with water and vented of air.

25.3 The pressure is to be increased from 0 to the test pressure at a rate not exceeding 300 psig (2.07 MPa) per min and then held for 1 min at the pressure specified in [Table 25.1](#). There shall be no visible leakage in any sample.

26 Hydrostatic Strength Test

26.1 An automatic sprinkler shall withstand, for 1 min, without rupture, an internal hydrostatic pressure equal to the hydrostatic test pressure shown in [Table 25.1](#).

26.2 The samples from the Leakage Test, Section [25](#), are to be used for this test.

26.3 The sprinkler inlets are to be filled with water and vented of air. The pressure is to be increased from 0 to the hydrostatic test pressure shown in [Table 25.1](#) at a rate not exceeding 300 psig (2.07 MPa) per min. The pressure is to be maintained at the test pressure and held for 1 min. The sample shall not rupture, operate, or release any of its operating parts during the pressure increase nor while being maintained at the test pressure for 1 min.

27 Dry Sprinkler Air Tightness Test

27.1 When tested as described in [27.2](#) and [27.3](#), the connection of the extension nipple to the inlet seal assembly for a dry-type pendent or sidewall sprinkler shall not exhibit leakage at any air pressure from 0 to 15 psig (0 to 103 kPa) when the pressure is applied externally to this connection.

27.2 At least five samples of the minimum length are to be individually tested. The assembly is to be installed in an air leakage test fixture in such a manner that the extension nipple connection to the inlet seal assembly can be fully pressurized with air. See [Figure 27.1](#).

Figure 27.1
Dry sprinkler air tightness test apparatus (typical)

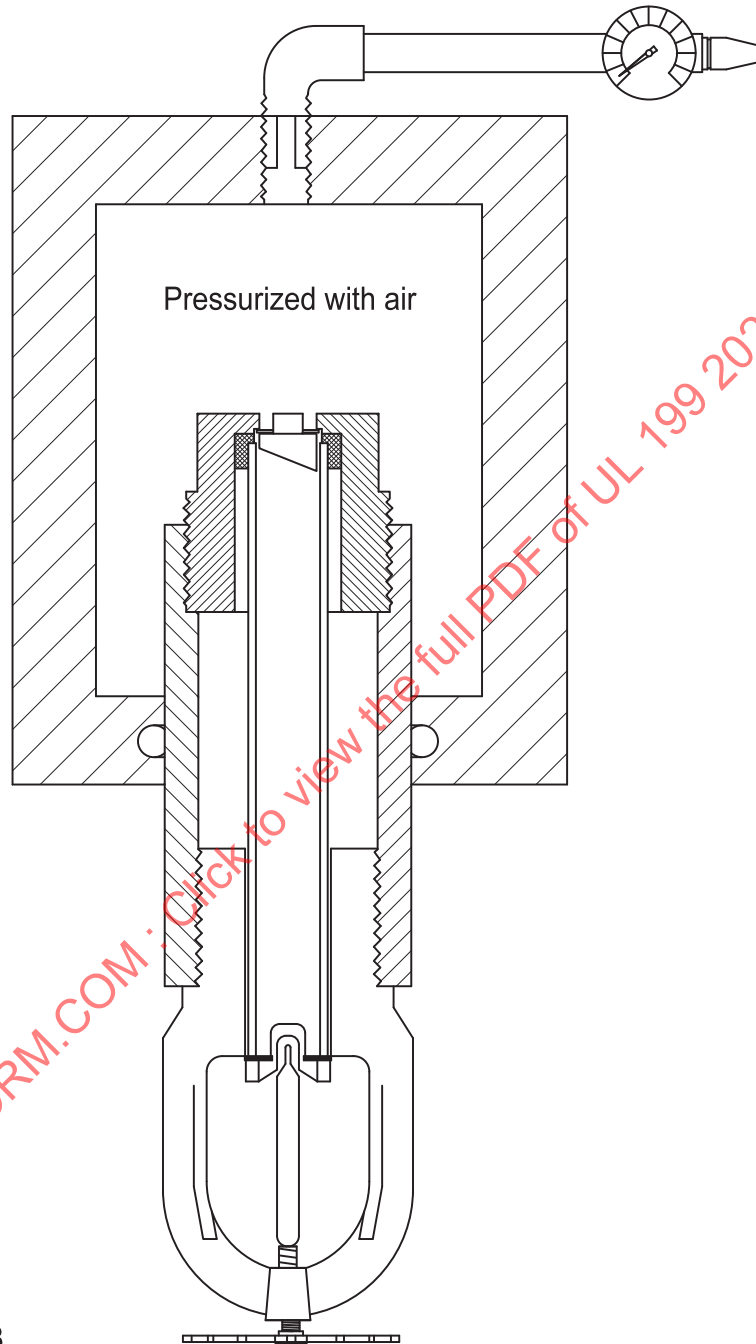

su0548

27.3 The assembly is to be immersed in water and orientated so that air bubbles indicating leakage past the extension nipple and inlet seal assembly connection point are allowed to freely escape from internal waterway of the dry sprinkler assembly. The air pressure applied to the connection point is then to be increased from 0 to 15 psig (0 to 103 kPa) within 30 s and then held for 30 s. Observations shall be made for leakage as evidenced by any air bubbles escaping from the internal portion of the dry sprinkler assembly.

28 30-Day Leakage Test

28.1 When tested as described in [28.2](#) – [28.4](#), an automatic sprinkler shall:

- a) Experience no leakage when subjected to the 30 day test pressure specified in [Table 28.1](#) for 30 days;
- b) Not leak when subjected to the leakage test pressure specified in [Table 25.1](#) or less for 1 min following the 30 days; and
- c) Show no distortion or other mechanical damage following the leakage testing, as determined by visual examination.

**Table 28.1
Test Pressures for the 30-Day Leakage Test**

Rated pressure		30-day test pressure	
psig	(MPa)	psig	(MPa)
175	(1.2)	300	(2.1)
250	(1.7)	450	(3.1)
300	(2.1)	500	(3.4)

28.2 Five samples are to be installed on a water-filled test line maintained under a constant test pressure as specified in [Table 28.1](#) for 30 days. The samples are to be examined during and at the end of the test period for evidence of leakage of water at the closure cap.

28.3 Following completion of this 30-day test period, the samples are to be tested to verify that they do not leak at the leakage test pressure specified in [Table 25.1](#) or at any lower pressure. The pressure is to be increased from 0 to the required test pressure a rate not exceeding 300 psig (2.07 MPa) per min. The pressure is to be maintained at the leakage test pressure specified in [Table 25.1](#) for 1 min, and is then to be decreased to 0 psig at a rate not exceeding 300 psig (2.07 MPa) per min.

28.4 The samples then are to be visually examined to verify there is no evidence of distortion or other mechanical damage.

29 Water Hammer Test

29.1 When tested as described in [29.2](#) – [29.5](#), an automatic sprinkler shall:

- a) Experience no leakage when subjected to 100,000 applications of pressure surges having a test pressure range as specified in [Table 29.1](#);
- b) Not leak when subjected to the leakage test pressure specified in [Table 25.1](#) for 1 min, following the 100,000 cycles of water hammer; and
- c) Show no distortion or other physical damage following the water hammer testing, as determined by visual examination.

Table 29.1
Test Pressure Ranges for the Water Hammer Test

Rated pressure		Test pressure range	
psig	(MPa)	psig	(MPa)
175	(1.2)	50 – 500	(0.34 – 3.4)
250	(1.7)	50 – 500	(0.34 – 3.4)
300	(2.1)	150 – 600	(1 – 4.1)

29.2 Five samples are to be installed on a water-filled test line connected to a pump system that produces a rapid rise in pressure in accordance with [Table 29.1](#) at the rate of not more than 60 cycles per min. The test piping is to be filled so that there is water at the sprinkler seat, and the pump is to be placed in operation and adjusted to produce the specified test-pressure cycle.

29.3 During the pressure cycling, observations are to be made for evidence of leakage.

29.4 Following completion of the pressure cycling, the samples are to be tested to verify that they do not leak at the leakage test pressure specified in [Table 25.1](#) or at any lower pressure. The pressure is to be increased from 0 to the required test pressure at a rate not exceeding 300 psig (2.07 MPa) per min. The pressure is to be maintained at the leakage test pressure specified in [Table 25.1](#) for 1 min, and is then to be decreased to 0 psig at a rate not exceeding 300 psig (2.07 MPa) per min.

29.5 The samples then are to be visually examined to verify there is no evidence of distortion or other mechanical damage.

30 Vacuum Test

30.1 An automatic sprinkler shall not be damaged and shall comply with the Leakage Test, Section [25](#), following exposure to a vacuum as specified in [30.2](#).

30.2 Five samples are to be installed on a manifold and subjected to a vacuum of minus 8.84 psi (18 in of mercury) (minus 61 kPa) for 1 min. The samples are then to be removed from the manifold, visually examined for damage, and then subjected to the Leakage Test, Section [25](#).

OPERATION TESTS

31 Operating Temperature (Bath) Test

31.1 The operating temperature of automatic sprinklers and cover plates, when tested as described in [31.1](#) – [31.7](#), shall be within a temperature range as follows:

- a) ± 3.5 % of the marked temperature rating for sprinklers rated less than 400 °F (204 °C); and
- b) 107 % of the marked temperature rating for sprinklers rated 400 °F (204 °C) and higher.

For the purpose of this determination for sprinklers rated 400 °F (204 °C) and higher, the marked temperature rating is to be the minimum value and included as one of the values within the range, making a total of eleven values in the range. Upon operation, all operating parts of the sprinkler shall clear the waterway as intended except as indicated in [31.2](#).

31.2 Sprinkler operation for this test includes the intended functioning of eutectic elements or any rupture of a glass bulb heat responsive element. If partial fracture of the glass bulb in the liquid environment occurs which does not result in sprinkler operation, the temperature at which bulb-fracture occurred shall

be considered the operating temperature, but additional sprinkler samples shall be subjected to the Air Bath for Glass Bulb Sprinkler Test, Section [32](#).

31.3 At least ten samples of each type of sprinkler produced of each temperature rating are to be subjected to this test. A sprinkler that does not require pressure to operate is to be tested at zero gauge pressure. A sprinkler that requires pressure to operate is to be tested while pressurized at $4\text{-}1/2 \pm 1/2$ psig (31 ± 3.4 kPa).

31.4 Water is to be used in bath tests of sprinklers that have operating temperature ratings of 175 °F (79 °C) or lower. Samples having operating temperature ratings of 176 – 575 °F (80 – 302 °C) are to be bath-tested in an oil having a flash point exceeding the test temperature.

31.5 The samples are to be placed in an upright position and completely immersed in the water or oil bath. The bath vessel is to be provided with a source for heating the liquid at the prescribed rate and with means to agitate the liquid and measure the temperature of the liquid bath.

31.6 A calibrated temperature measuring device is to be used to determine temperature of the liquids in bath tests. The sensing element of the temperature measuring device is to be held level with the sprinkler operating parts by a support member.

31.7 The temperature of the bath liquid is to be increased at a convenient rate until the liquid is within 20 °F (11 °C) of the temperature rating of the device [30 °F (16 °C) for 325 °F (163 °C) and higher temperature ratings]. The rate of temperature rise then is to be controlled at a constant rate of 1 ± 0.2 °F (0.5 ± 0.1 °C) per min until operation of the sprinkler or until a temperature 20 °F (11 °C) above the rated temperature is reached. The temperature of the liquid and the time of operation, as each sprinkler operates, are to be recorded.

32 Air Bath for Glass Bulb Sprinkler Test

32.1 When a partial fracture of a glass bulb occurs during the Operating Temperature (Bath) Test, Section [31](#), sprinklers with a glass bulb heat responsive element shall fully operate when subjected to the air bath test described in [32.2](#).

32.2 Fifty sample sprinklers with a glass bulb heat responsive element shall be placed on their inlet in a programmable circulating air oven. The temperature in the oven shall be gradually increased to 20 ± 2 °F (11 ± 1.1 °C) below the marked temperature rating of the sprinklers. When this temperature is reached, the oven shall be maintained at a constant temperature for a period of 60 ± 5 min. The temperature shall then be increased at a constant rate of 1 ± 0.5 °F (0.5 ± 0.3 °C) per min until the temperature in the oven is 25 % higher than the marked temperature rating of the sprinklers or until all the sprinklers operate, whichever occurs first. Each sample shall be examined for full operation.

33 Sensitivity Tests

33.1 General

33.1.1 An automatic sprinkler shall comply with the requirements as referenced in [Table 33.1](#) based upon the sprinkler type:

Table 33.1
Sensitivity Requirements by Sprinkler Type

Sprinkler type	Requirements
Standard Response (all except flush, recessed and concealed; and extended coverage)	33.2.1
Standard Response Flush, Recessed and Concealed, and Standard Response Extended Coverage	33.2.1 and 33.3.1
Quick Response(all)	33.2.2 and 33.3.2
Residential	33.2.2 and 33.3.2
ESFR	33.2.3

33.1.2 A coating shall not remain on sprinkler parts in a manner that impairs operation or distribution at the time of sprinkler operation in [33.2](#) and [33.3](#).

33.2 Oven heat test

33.2.1 A standard response sprinkler shall operate within the time range specified in [Table 33.2](#) for each sample sprinkler when tested in the Oven Heat Test as specified in [33.2.4](#) – [33.2.6](#). If the sprinkler temperature is not shown in [Table 33.2](#), the minimum and maximum operating time range for each sample sprinkler shall be determined by using the formula specified in [33.2.7](#), based on a RTI value of $80 \text{ (m}\cdot\text{s)}^{1/2}$ [$145 \text{ (ft}\cdot\text{s)}^{1/2}$] for the minimum value and on a RTI value of $350 \text{ (m}\cdot\text{s)}^{1/2}$ [$630 \text{ (ft}\cdot\text{s)}^{1/2}$] for the maximum value, and the marked temperature rating of the sprinkler.

Exception: The minimum operating time for the Oven Heat Test does not apply to standard response extended coverage and ceiling sprinklers complying with [33.3.1](#).

33.2.2 QR, QR extended coverage and residential sprinklers shall have the following operating time characteristics when tested in the sensitivity test oven as specified in [33.2.4](#) – [33.2.6](#):

a) A maximum operating time specified in [Table 33.2](#) for each sample sprinkler in the as-received condition. If the sprinkler temperature rating is not shown in [Table 33.2](#), the maximum operating time for each sample sprinkler shall be determined by using the formula specified in [33.2.7](#) based on a Response Time Index (RTI) value of $50 \text{ (m}\cdot\text{s)}^{1/2}$ [$90 \text{ (ft}\cdot\text{s)}^{1/2}$], and the marked temperature rating of the sprinkler.

b) Mean operating time after being subjected to the exposure tests specified in Sections [36](#), [44](#), and [45](#) shall be equal to or less than a 1.30 multiple of the mean operating time of the sprinkler tested in the as-received condition.

**Table 33.2
Operating Time in Oven Heat Test for Quick Response, Residential and Standard Response Sprinklers**

Sprinkler temperature rating		Oven temperature		Quick response and residential ^b type, s	Standard response type, s		Coated standard response type, s ^a
°F	(°C)	°F	(°C)	Max.	Min.	Max.	Max.
135	(57.2)	275	(135)	11.2	17.8	78.3	180
140	(60.0)	275	(135)	12.3	19.7	86.3	180
155	(68.3)	275	(135)	16.0	25.6	112.2	180
160	(71.1)	275	(135)	17.3	27.7	121.5	180
165	(73.9)	275	(135)	18.7	30.0	131.3	180
175	(79.4)	386	(197)	12.1	19.4	85.2	180
200	(93.3)	386	(197)	16.1	25.7	112.9	180
212	(100.0)	386	(197)	18.2	29.0	127.5	180
220	(104.4)	386	(197)	19.7	31.8	137.9	180
250	(121.1)	555	(291)	14.2	22.7	99.6	180
286	(141.1)	555	(291)	18.1	29.0	127.2	180
300	(148.9)	555	(291)	19.8	31.7	138.9	180
360	(182.2)	765	(407)	16.7	26.8	117.0	180
400	(204.4)	765	(407)	20.0	32.0	139.8	180
450	(232.2)	765	(407)	24.6	39.4	172.2	180
500	(260.0)	765	(407)	30.0	48.1	210.2	210.3

^a Corrosion resistant sprinklers with coated heat responsive elements including wax, lead, Teflon, wax over lead, and polyester coating. Coated quick response sprinklers shall comply with [33.2.2](#).

^b Residential sprinklers shall have a temperature rating within the ordinary and intermediate classifications.

33.2.3 An ESFR sprinkler shall have the following sensitivity characteristics when tested in the sensitivity test oven as specified in [33.2.4](#)–[33.2.8](#).

- a) An RTI not exceeding $36 (m \cdot s)^{1/2}$ [$65 (ft \cdot s)^{1/2}$] in the as-received condition, and
- b) Mean operating time after being subjected to the exposure tests specified in Sections [36](#), [44](#), and [45](#) shall be equal to or less than a 1.30 multiple of the mean operating time of the sprinklers tested in the as-received condition when tested in the most favorable orientation.

Exception: An ESFR sprinkler shall be permitted to have an RTI greater than $36 (m \cdot s)^{1/2}$ [$65 (ft \cdot s)^{1/2}$] but not exceeding $50 (m \cdot s)^{1/2}$ [$90 (ft \cdot s)^{1/2}$] when fire suppression can be demonstrated during large scale fire tests representing the installation conditions, protected storage configurations, and protected commodity specified for the sprinkler utilizing a higher RTI heat responsive element. See Section [55](#) for examples of large scale fire tests