



UL 1740

STANDARD FOR SAFETY

Robots and Robotic Equipment

[ULNORM.COM](https://www.ulnorm.com) : Click to view the full PDF of UL 1740 2020

[ULNORM.COM](https://www.ulnorm.com) : Click to view the full PDF of UL 1740 2020

UL Standard for Safety for Robots and Robotic Equipment, UL 1740

Fourth Edition, Dated January 26, 2018

Summary of Topics

This revision of ANSI/UL 1740 dated November 17, 2020 includes changes regarding illuminated e-stop; [40.2.2.2](#).

Text that has been changed in any manner or impacted by UL's electronic publishing system is marked with a vertical line in the margin.

The revised requirements are substantially in accordance with Proposal(s) on this subject dated May 1, 2020 and September 18, 2020.

All rights reserved. No part of this publication may be reproduced, stored in a retrieval system, or transmitted in any form by any means, electronic, mechanical photocopying, recording, or otherwise without prior permission of UL.

UL provides this Standard "as is" without warranty of any kind, either expressed or implied, including but not limited to, the implied warranties of merchantability or fitness for any purpose.

In no event will UL be liable for any special, incidental, consequential, indirect or similar damages, including loss of profits, lost savings, loss of data, or any other damages arising out of the use of or the inability to use this Standard, even if UL or an authorized UL representative has been advised of the possibility of such damage. In no event shall UL's liability for any damage ever exceed the price paid for this Standard, regardless of the form of the claim.

Users of the electronic versions of UL's Standards for Safety agree to defend, indemnify, and hold UL harmless from and against any loss, expense, liability, damage, claim, or judgment (including reasonable attorney's fees) resulting from any error or deviation introduced while purchaser is storing an electronic Standard on the purchaser's computer system.

No Text on This Page

ULNORM.COM : Click to view the full PDF of UL 1740 2020

JANUARY 26, 2018
(Title Page Reprinted: November 17, 2020)



ANSI/UL 1740-2020

1

UL 1740

Standard for Robots and Robotic Equipment

First Edition – February, 1995
Second Edition – November, 1998
Third Edition – December, 2007

Fourth Edition

January 26, 2018

This ANSI/UL Standard for Safety consists of the Fourth Edition including revisions through November 17, 2020.

The most recent designation of ANSI/UL 1740 as an American National Standard (ANSI) occurred on October 20, 2020. ANSI approval for a standard does not include the Cover Page, Transmittal Pages, and Title Page.

Comments or proposals for revisions on any part of the Standard may be submitted to UL at any time. Proposals should be submitted via a Proposal Request in UL's On-Line Collaborative Standards Development System (CSDS) at <https://csds.ul.com>.

UL's Standards for Safety are copyrighted by UL. Neither a printed nor electronic copy of a Standard should be altered in any way. All of UL's Standards and all copyrights, ownerships, and rights regarding those Standards shall remain the sole and exclusive property of UL.

COPYRIGHT © 2020 UNDERWRITERS LABORATORIES INC.

No Text on This Page

ULNORM.COM : Click to view the full PDF of UL 1740 2020

CONTENTS

INTRODUCTION

1	Scope	7
2	Glossary	7
3	Components	15
4	Units of Measurement	16
5	Undated References	16

CONSTRUCTION

6	General	16
7	Frame and Enclosure	16
	7.1 General	16
	7.2 Cast metal	16
	7.3 Sheet metal.....	17
	7.4 Doors and covers	19
	7.5 Nonmetallic – General	23
	7.6 Bonding	24
	7.7 Parts of enclosures	24
	7.8 Windows.....	24
	7.9 Openings in enclosures – Ventilating openings	25
8	Mounting	26
9	Clearance	27
10	Operating Mechanism.....	27
11	Accessibility of Uninsulated Live Parts, Film-Coated Wire, and Moving Parts	27
12	Protection Against Corrosion.....	32
13	Polymeric Materials	33
	13.1 General.....	33
	13.2 Small parts	33
	13.3 Insulating material	34
14	Field Connections	34
	14.1 General.....	34
	14.2 Terminals	36
15	Cord Connected Robotic Equipment	37
16	Strain Relief	37
17	Bushings	37
18	Current-Carrying Parts.....	37
19	Conductors	38
	19.1 General.....	38
	19.2 Interconnecting cords and cables	41
	19.3 Interconnection of units	41
20	Grounding	42
	20.1 General.....	42
	20.2 Grounding means	42
	20.3 Terminals and leads	42
21	Bonding of Internal Parts.....	43
	21.1 General.....	43
	21.2 Construction and connection	45
22	Motors	46
23	Printed-Wiring Boards.....	47
24	Transformers	47
25	Capacitors, Capristors and Varistors	47
	25.1 Isolating components	47

25.2	Across-the-line components	47
25.3	General.....	48
26	Supply-Circuit Disconnecting Means.....	48
26.1	General.....	48
26.2	Position indication.....	48
26.3	Supply conductors to be disconnected	48
26.4	Connections to supply lines	48
26.5	Exposed live parts	49
26.6	Mounting.....	49
26.7	Electrical cabinet interlocks (Not intended for Functional Safety of a Workcell)	49
26.8	Operating handle.....	49
26.9	Attachment plug and receptacle.....	49
27	Overcurrent Protection, Control-Circuit Conductors.....	50
28	Spacings	51
28.1	General.....	51
28.2	Clearance and creepage distances	51
29	Field Wiring Space	53
30	Separation of Circuits	54
31	Use with lasers or X-Radiation.....	55

PROTECTION AGAINST INJURY TO PERSONS

32	General	55
33	Sharp Corners and Edges.....	55
34	Moving Parts – Other Than the Robot	55
35	Moving Parts – Drive Power Indicator	56
35.1	General.....	56
35.2	Limiting robot motion.....	56
35.3	Robot control system	57
35.4	Emergency movement without drive power and brake release	57
36	Temperature	57
37	Mounting Devices.....	57
38	Parts Subject to Pressure.....	58
39	Pressure-Relief Devices.....	58
40	Protection of Users and Service Personnel.....	59
40.1	General.....	59
40.2	Robot control.....	60
40.3	Actuating controls	61
40.4	Robot manual mode.....	61
40.5	Pendant	61
40.6	Robot system workcell protection.....	62
40.7	Safeguarding requirements for maintenance – General	62
40.8	Electrical servicing	63
41	Batteries and Battery Circuits	63
41.1	General.....	63
41.2	Battery and fuel cell terminals	63
41.3	Lithium batteries	63
41.4	Non-lithium battery circuits	64
41.5	Fuel cells	64
42	Accessories and Attachments	64

PERFORMANCE

43	General	64
44	Power Input and Maximum Ampacity Test.....	65

44.1	Power input	65
44.2	Maximum ampacity	65
45	Temperature Test	65
46	Overvoltage and Undervoltage Tests	70
47	Leakage Current Test	70
48	Robots Intended for Use in Water Environments	73
49	Outdoor-Use Tests	73
50	Maximum Low Voltage Measurement	73
51	Energy Storage and Energy Storage Circuit Tests – Electrical	74
51.1	Battery or super-capacitor (Ultra-cap) overcharge	74
51.2	Battery or super-capacitor discharge	74
51.3	Battery / battery pack drop	74
51.4	Energy storage test results	74
51.5	Energy Source low voltage – program memory loss	75
52	Pendant Tests: Drop, Handle and Mounting Means	75
52.1	General	75
52.2	Pendant: Handle and mounting means	75
52.3	Pendant: Enabling device	75
53	Interconnecting Cords and Cables Test	76
54	Abnormal Operation Test	76
54.1	General	76
54.2	Loss of primary power single phase test	76
54.3	Locked ventilation motor test	77
54.4	Blocked mechanical filter test	77
54.5	Locked drive motor test	77
54.6	Locked brake test	77
55	Component Breakdown Test	77
56	Overload Test	78
57	Endurance Test	78
58	End of Travel Hardstop Test	78
59	Power Loss and Power Restoration Test	78
60	Emergency Stop Operation Test and Maximum Stopping Time and Distance or Angle Verification	78
61	Enabling Device Verification	79
62	Emergency Movement of Robot Without Drive Power Test (See 35.4)	79
63	Gripper (End-Effector) Test	79
64	Manual Mode Reduced Speed Measurement	79
65	Voltage Surge Test	80
66	Dielectric Voltage-Withstand Test	80
66.1	General	80
66.2	Power transformer dielectric withstand	82
67	Burnout Test (Transformer Overload)	82
68	Ground Resistance Test	83
69	Strain Relief Test	83
70	Flexing Test	83
71	Physical Stability Test	83
72	Lifting/Transportation Means Loading Test	84
73	Mounting Devices Test	84
74	Parts Subject to Pressure Tests	84
75	Pressure-Relief Devices Test	85
76	Enclosure Test	85
77	Horizontal Surface Loading Test	86
78	Gasket Tests	86
79	Glass Window Impact Test	86
80	Securement of Snap-On Cover Test	86
81	Wheel or Caster Securement	87

82	Electromagnetic Compatibility (EMC).....	87
83	Functional Safety Analysis	87
	83.1 General.....	87
	83.2 Analysis program.....	87
	83.3 Provisions for redundancy	88
	83.4 Use of diversity	88

MANUFACTURING AND PRODUCTION TESTS

84	Production-Line Dielectric Voltage-Withstand Test – General.....	88
85	Production-Line Grounding-Continuity Test	90
86	Production-Line Polarization-Continuity Test.....	90

RATING

87	Details	90
----	---------------	----

MARKING

88	General	90
89	Wiring.....	92
90	Elevated Ambient Temperature	94
91	Cautionary Markings.....	95

MANUFACTURER SUPPLIED DOCUMENTATION

92	Manufacturer's Documentation	97
----	------------------------------------	----

Appendix A Standards for Components

ULNORM.COM : Click to view the full PDF of UL 1740 2020

INTRODUCTION

1 Scope

1.1 These requirements cover robots and robotic equipment rated 600 V or less and intended for installation in accordance with the National Electrical Code, NFPA 70. Equipment evaluated to these requirements is intended to meet the requirements of Robots and Robotic Devices – Safety Requirements for Industrial Robots – Part 1, ISO 10218-1, and can be installed in accordance with ISO 10218-1, Robots and Robotic Devices – Safety Requirements for Industrial Robots – Part 1 and ISO 10218-2, Robots and Robotic Devices – Safety Requirements for Industrial Robots – Part 2: Robot Systems and Integration.

1.2 These requirements cover robotic equipment and systems intended for indoor and outdoor use in applications such as parts assembly, parts transfer, automated material handling, inspection, loading, die-casting, deburring, welding, paint spraying, automated storage/retrieval systems, and the like.

1.3 Robots and robotic equipment that contain unique features or functions associated with the application or end-product equipment, and not specifically addressed in this standard or referenced standards, shall also be evaluated to the applicable requirements of standards for the application or end-product equipment.

1.4 In addition to the requirements in this standard, robots and robotic systems shall also comply with the applicable sections of the Electrical Standard for Industrial Machinery, NFPA 79.

1.5 Robots and robotic systems intended for use in hazardous locations, as defined by the National Electrical Code, NFPA 70, shall also comply with the applicable safety requirements based on the specific end-use application, including those contained in the following standards:

- a) Intrinsically Safe Apparatus and Associated Apparatus for Use in Class I, II, and III, Division 1, Hazardous (Classified) Locations, UL 913;
- b) Explosion-Proof and Dust-Ignition-Proof Electrical Equipment for Use in Hazardous (Classified) Locations, UL 1203;
- c) Nonincendive Electrical Equipment for Use in Class I and II, Division 2 and Class III, Divisions 1 and 2 Hazardous (Classified) Locations, ISA 12.12.01;
- d) Electric Motors and Generators for Use in Hazardous (Classified) Locations, UL 674; and
- e) Purged and Pressurized Enclosures for Electrical Equipment, NFPA 496.

1.6 In the following text, a requirement that applies to one type of equipment, such as a controller or pendant, will be identified by a specific reference. In the absence of a specific reference or if the term robot or robotic equipment is employed, it is to be understood that the requirement applies to all types of equipment covered by this standard.

2 Glossary

2.1 For the purpose of this standard the following definitions apply.

2.2 **AUTOMATIC OPERATION** – The time when a robot is performing its programmed tasks through continuous program execution.

2.3 **AWARENESS SIGNAL** – A device that warns a person of an approaching or present hazard by an audible or visible means. A visible means could include a text message or display on a pendant or user interface screen.

2.4 CATEGORY – Classification of the Safety-Related Parts of a Control System (SRP/CS) in respect of their resistance to faults and their subsequent behavior in the fault condition, and which is achieved by the structural arrangement of the parts, fault detection and/or by their reliability.

©ISO. This material is reproduced from ISO 13849-1:2015 with permission of the American National Standards Institute (ANSI) on behalf of the International Standardization Organization. All rights reserved.

2.5 CLASS 2– A circuit, transformer, or power source having energy- and voltage-limiting characteristics as described in Standard for Low Voltage Transformers – Part 3: Class 2 and Class 3 Transformers, UL 5085-3.

2.6 COLLABORATIVE OPERATION – State in which a purposely designed robot system and an operator work within a collaborative workspace.

©ISO. This material is reproduced from ISO/TS 15066 with permission of the American National Standards Institute (ANSI) on behalf of the International Organization for Standardization. All rights reserved. ISO/TS 15066 was an ISO draft document that was subject to change without notice. It cannot be referred to as an approved ISO standard.

2.7 COLLABORATIVE WORKSPACE – Space within the operating space where the robot system (including the workpiece) and a human can perform tasks concurrently during production operation.

©ISO. This material is reproduced from ISO/TS 15066 with permission of the American National Standards Institute (ANSI) on behalf of the International Organization for Standardization. All rights reserved. ISO/TS 15066 was an ISO draft document that was subject to change without notice. It cannot be referred to as an approved ISO standard.

2.8 DRIVE POWER – The source or means of supplying energy to the robot actuators to produce motion.

2.9 ELECTRICAL/ ELECTRONIC/ PROGRAMMABLE ELECTRONIC E/E/PE – Based on Electrical (E) and/or Electronic (E) and/or Programmable Electronic (PE) technology.

NOTE – The term is intended to cover any and all devices or systems operating on electrical principles.

EXAMPLE: Electrical/electronic/programmable electronic devices include:

- Electro-mechanical devices (electrical);
- Solid-state non-programmable electronic devices (electronic);
- Electronic devices based on computer technology (programmable electronic).

©IEC. This material is reproduced from IEC 61508-4 Ed. 2.0 b:2010, with permission of the American National Standards Institute (ANSI) on behalf of International Electrotechnical Commission. All rights reserved.

2.10 EMERGENCY STOP (FUNCTION) – Function which is intended to:

- a) Avert arising or reduce existing hazards to persons, damage to machinery or to work in progress; and
- b) Be initiated by a single human action.

©ISO. This material is reproduced from ISO 12100:2010 with permission of the American National Standards Institute (ANSI) on behalf of the International Standardization Organization. All rights reserved.

2.11 ENABLING DEVICE – A manually operated device which, when continuously activated, permits motion.

2.12 END-EFFECTOR – An accessory device or tool specifically designed for attachment to the robot wrist or tool mounting plate to enable the robot to perform its intended task. (Examples may include gripper, spot weld gun, arc weld gun, spray paint gun, or any other application tools.)

2.13 FIELD-WIRING TERMINAL – A wiring terminal on permanently connected equipment to which connections are made when the equipment is installed in the field.

2.14 FUNCTIONAL SAFETY (FS) – Part of the overall safety relating to the Equipment Under Control (EUC) and the EUC control system that depends on the correct functioning of the E/E/PE safety-related systems and other risk reduction measures.

©IEC. This material is reproduced from IEC 61508-4 Ed. 2.0 b:2010, with permission of the American Standards Institute (ANSI) on behalf of International Electrotechnical Commission. All rights reserved.

2.15 INTERLOCK – An arrangement which allows the operation of one control or mechanism, or prevents the operation of another.

2.16 ISOLATED LIMITED-ENERGY SECONDARY CIRCUIT – A circuit derived from an isolated secondary winding of a transformer having a maximum capacity of 100 Volt-Amperes and an open-circuit secondary-voltage rating not exceeding 1000 V.

2.17 ISOLATED LOW-VOLTAGE LIMITED-ENERGY – A circuit involving a potential of not more than 42.4 V (60 V dc) peak supplied by one of the following:

a) An energy-limiting Class 2 transformer;

b) A nonenergy-limiting Class 2 transformer and an overcurrent protective device. The protective device is:

1) Not to be of the automatic reclosing type;

2) To be trip-free from the reclosing mechanism; and

3) Not to be readily interchangeable with a device of a different rating.

c) A combination of an isolated transformer secondary winding and a fixed impedance that complies with all the performance requirements for an energy-limiting Class 2 transformer or a non-isolated low-voltage limited-energy power source;

d) A dry-cell battery having output characteristics not greater than those of an energy-limiting Class 2 transformer or a non-isolated low-voltage limited-energy power source; or

e) A combination of a rechargeable battery and a fixed impedance that complies with all of the performance requirements for an energy-limiting Class 2 transformer or a non-isolated low-voltage limited-energy power source.

2.18 MANUAL MODE – Control state that allows for the direct control by an operator.

©ISO. This material is reproduced from ISO 10218-1:2011 with permission of the American National Standards Institute (ANSI) on behalf of the International Standardization Organization. All rights reserved.

2.19 NON-ISOLATED LOW-VOLTAGE LIMITED-ENERGY POWER SOURCE – A circuit derived from a source of supply classified as line voltage by connecting impedance in series with the supply circuit as a means of limiting the voltage and power to comply with Class 2 characteristics.

2.20 OPEN TYPE (PRODUCT) – (Product) Intended for incorporation within enclosure or assembly which will provide access protection.

2.21 OPERATOR – The person designated to start, monitor and stop the intended productive operation of a robot or robot system. An operator may also interface with a robot for productive purposes.

2.22 OPPOSITE POLARITY – A difference of potential between two points, where shorting of these two points would result in a condition involving overload, rupturing of printed-wiring board foil pattern, components, or fuses, and the like.

2.23 PAYLOAD – The rated mass of the end-effector and material, that can be handled by a robot in a normal and continuous operation. Other mechanical characteristics may also affect payload rating, such as center of mass, etc.

2.24 PENDANT – Hand held unit linked to the control system with which a robot can be programmed or moved.

©ISO. This material is reproduced from ISO 10218-1:2011 with permission of the American National Standards Institute (ANSI) on behalf of the International Standardization Organization. All rights reserved.

2.25 PERFORMANCE LEVEL (PL) – Discrete level used to specify the ability of safety-related parts of control systems to perform a safety function under foreseeable conditions.

©ISO. This material is reproduced from ISO 13849-1:2015 with permission of the American National Standards Institute (ANSI) on behalf of the International Standardization Organization. All rights reserved.

2.26 POLLUTION – Any addition of contaminants, solid, liquid or gaseous (ionized gases), and moisture that may produce a reduction of dielectric strength or surface resistivity.

2.27 POLLUTION DEGREE – The level of pollution present at the location on or in a product where the clearance and creepage distance measurement is made, and can be controlled by design of the product. For example, enclosures can be used to achieve Pollution Degree 3, heaters within enclosures can help achieve Pollution Degree 2, and encapsulation can be used to achieve Pollution Degree 1.

2.28 PRIMARY CIRCUIT – The wiring and components that are conductively connected to the supply circuit.

2.29 PROGRAM –

- a) A sequence of instructions to be executed by the computer or robot controller to control a robot/robot system;
- b) To furnish (a computer) with a code of instructions;
- c) To teach a robot system a specific set of movements and instructions to accomplish a task.

2.30 PROTECTIVE DEVICE – A device designed, constructed and installed to create a sensing field or area to detect an intrusion into that field or area by personnel, robot(s), or other objects.

2.31 PROTECTIVE STOP – Type of interruption of operation that allows a cessation of motion and related hazards for safeguarding purposes and which retains the program logic to facilitate a restart.

Adapted by UL from ISO 10218-1:2011 with permission of the American National Standards Institute (ANSI) on behalf of the International Organization of Standardization. All rights reserved.

2.32 QUALIFIED PERSON – One familiar with the construction and operation of the equipment and the hazard(s) involved.

2.33 REDUNDANCY – The application of more than one device or system, or part of a device or a system, such that if one fails to perform its function, another is available to perform that function.

2.34 RISK OF ELECTRIC SHOCK – Under normal conditions a risk of electric shock exists between any two conductive parts or between a conductive part and earth ground if the continuous current flow between the two points exceeds the leakage current limits determined by the Leakage Current Test, Section 47, and if the open circuit voltage exceeds the limits in Table 2.1. Under fault or abnormal conditions: a risk of electric shock is considered to exist at any part at the potentials in Table 2.1 and when the continuous current flow through a 500 ohm resistor connected across the potential exceeds 5.0 mA.

Table 2.1
Risk of electric shock threshold

Waveform type ^a	Maximum voltage	
	Dry and damp locations	Wet locations
Sinusoidal ac	30 V rms	15 V rms
Non-sinusoidal ac	42.4 V peak	21.2 V peak
dc ^{b, c}	60 V	30 V

^a The voltage limits for a composite AC + DC waveform (V peak) shall be per Figure 2.1 based on the Direct Voltage component (V DC) of the waveform. The graph line for locations where wet contact is not likely to occur refers to Dry and Damp locations. The graph line for locations where wet contact is likely to occur refers to wet locations.

^b If the peak-to-peak ripple voltage on a dc waveform exceeds 10 percent of the dc voltage, the waveform shall be considered a composite waveform per footnote a above.

^c DC waveforms interrupted at frequencies between 10 – 200 Hz shall be limited to 24.8 V in dry and damp locations, and 12.4 V in wet locations.

Figure 2.1
Voltage limits

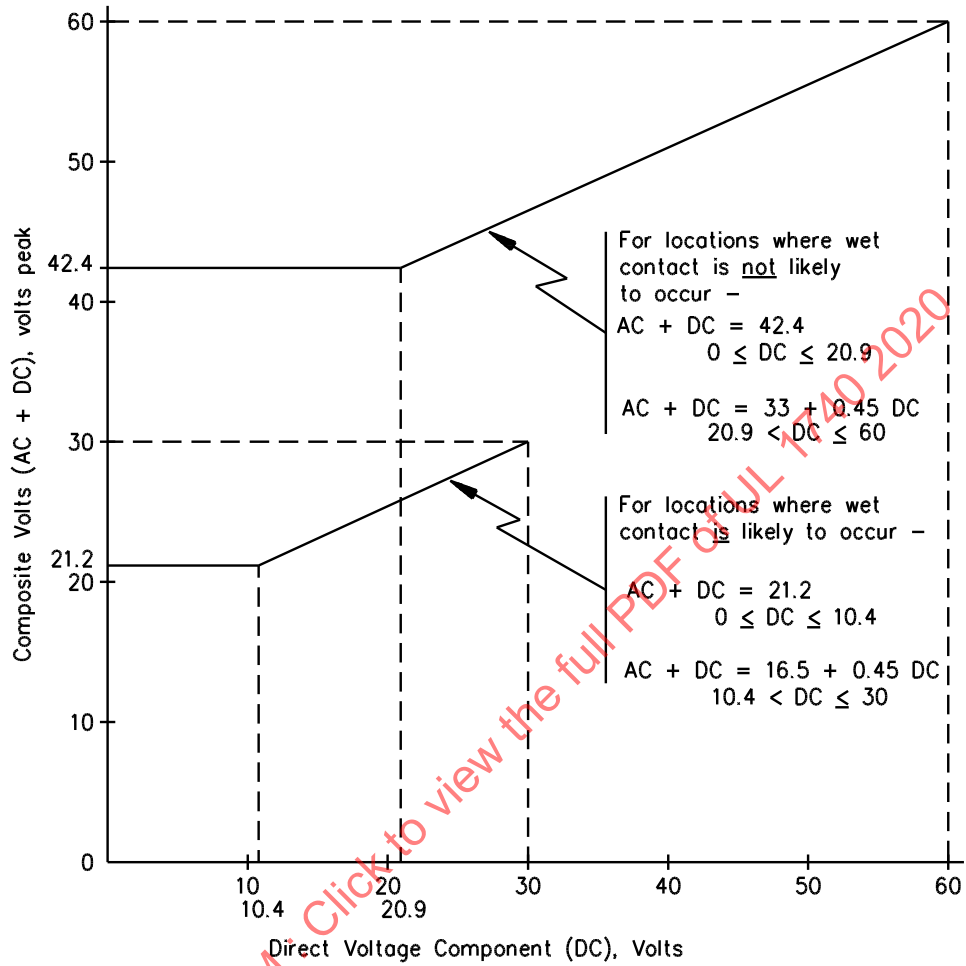

S3253A

ULNORM.COM Click to view the full PDF of UL 1740 2020

2.35 RISK OF FIRE – A risk of fire is considered to exist at any two points in a circuit where the open circuit voltage is more than 42.4 V peak and the energy available to the circuit under any condition of load including short circuit, results in a current of 8 A or more after 1 minute of operation.

2.36 ROBOT – Actuated mechanism programmable in two or more axes with a degree of autonomy, moving within its environment, to perform intended tasks.

1 A robot includes the control system and interface of the control system.

2 The classification of robot into industrial robot or service robot is done according to its intended application.

©ISO. This material is reproduced from ISO 8373:2012 with permission of the American National Standards Institute (ANSI) on behalf of the International Standardization Organization. All rights reserved.

2.37 ROBOTIC SYSTEM – A system that includes the robot (hardware and software) consisting of the robot, the end-effector(s), any equipment, devices, or sensors required for the robot to perform its tasks; and any communication interface that is operating and monitoring the robot, equipment, or sensors, as far as these peripheral devices are supervised by the robot control system.

2.38 SAFEGUARD – Guard or protective device.

©ISO. This material is reproduced from ISO 12100:2010 with permission of the American National Standards Institute (ANSI) on behalf of the International Standardization Organization. All rights reserved.

2.39 SAFETY CIRCUIT – A primary or secondary circuit containing a control that is relied upon to reduce a risk of fire, electric shock, or injury to persons at the controlled equipment.

2.40 SAFETY CONTROL – An automatic control and interlock (including relays, switches, and other auxiliary equipment used to form a system) that is intended to reduce the risk of fire, electric shock, or injury to persons.

2.41 SAFETY INTEGRITY LEVEL (SIL) – Discrete level (one out of a possible four), corresponding to a range of safety integrity values, where SIL 4 has the highest level of safety integrity and SIL 1 has the lowest.

©IEC. This material is reproduced from IEC 61508-4 Ed. 2.0 b:2010, with permission of the American Standards Institute (ANSI) on behalf of International Electrotechnical Commission. All rights reserved.

2.42 SAFETY-RELATED PART OF A CONTROL SYSTEM (SRP/CS) – Part of a control system that responds to safety-related input signals and generates safety-related output signals.

NOTE 1: The combined safety-related parts of a control system start at the point where the safety-related input signals are initiated (including, for example, the actuating cam and the roller of the position switch) and end at the output of the power control elements (including, for example, the main contacts of a contactor).

NOTE 2: If monitoring systems are used for diagnostics, they are also considered as SRP/CS.

©ISO. This material is reproduced from ISO 13849-1:2015 with permission of the American National Standards Institute (ANSI) on behalf of the International Standardization Organization. All rights reserved.

2.43 SECONDARY CIRCUIT – A circuit supplied from a secondary winding of an isolating transformer.

2.44 SENSOR – A device that responds to physical stimuli (such as heat, light, sound, pressure, magnetism, motion) and transmits the resulting signal or data providing a measurement, operating a control, or both.

2.45 SINGLE POINT OF CONTROL – The ability to operate the robot such that initiation of robot motion from one source of control is only possible from that source and cannot be overridden from another source.

2.46 SINGULARITY – Condition where the motion of a set of robot joints produces no net Cartesian motion (translational or rotational) of either the robot flange or the Tool Center Point (TCP). Cartesian motions that pass near this condition can produce unexpected high joint speeds, which can be hazardous. A singularity can also be defined as an occurrence whenever the rank of the Jacobian matrix becomes less than full rank – Mathematically, in a singular configuration, the joint velocity in joint space can become infinite to maintain Cartesian velocity. In actual operation, motions defined in Cartesian space that pass near singularities can produce high joint speeds. These high speeds can be unexpected to an operator. [Figure 2.2](#) below demonstrates the robot behavior as the wrist passes near the 'shoulder' singularity, as the robot moves the tool linearly from point A (with the elbow at point C) to point B (with the elbow at point E), Joint 1 rotates rapidly from a configuration where the elbow is at point D, finally ending at configuration with the elbow at point E.

Adapted by UL from ISO 10218-1:2011 with permission of the American National Standards Institute (ANSI) on behalf of the International Organization of Standardization. All rights reserved.

Figure 2.2
Singularity diagram

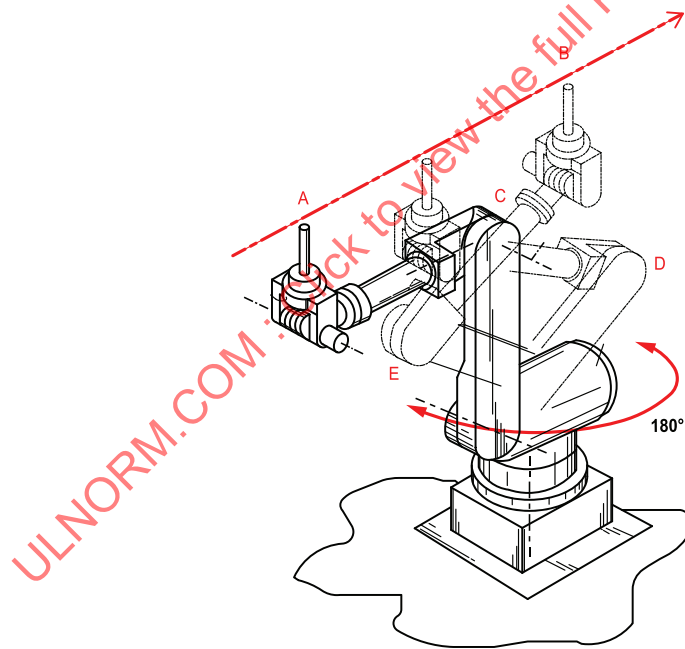

su2291

This modified figure above is being used with Permission from FANUC America Corporation.

2.47 SPACE – Three dimensional volume.

©ISO. This material is reproduced from ISO 10218-1:2011 with permission of the American National Standards Institute (ANSI) on behalf of the International Standardization Organization. All rights reserved.

2.48 SPACE, MAXIMUM – Space which can be swept by the moving parts of the robot as defined by the manufacturer plus the space which can be swept by the end-effector and the workpiece.

©ISO. This material is reproduced from ISO 10218-1:2011 with permission of the American National Standards Institute (ANSI) on behalf of the International Standardization Organization. All rights reserved.

2.49 SPACE, OPERATING – Portion of the restricted space that is actually used while performing all motions commanded by the task program.

©ISO. This material is reproduced from ISO 10218-1:2011 with permission of the American National Standards Institute (ANSI) on behalf of the International Standardization Organization. All rights reserved.

2.50 SPACE, RESTRICTED – Portion of the maximum space restricted by limiting devices that establish limits which will not be exceeded.

©ISO. This material is reproduced from ISO 10218-1:2011 with permission of the American National Standards Institute (ANSI) on behalf of the International Standardization Organization. All rights reserved.

2.51 SPACE, SAFEGUARDED – Space defined by the perimeter safeguarding.

©ISO. This material is reproduced from ISO 10218-1:2011 with permission of the American National Standards Institute (ANSI) on behalf of the International Standardization Organization. All rights reserved.

2.52 STATIONARY EQUIPMENT – Hard wired or cord- and plug-connected equipment that is intended to be fastened in place, or located in a dedicated space.

2.53 TEACHER – A person who provides the robot with a specific set of instructions to perform a task.

2.54 TOOL CENTER POINT (TCP) – The origin of the tool coordinate system.

2.55 USER SERVICING – Any form of servicing that can be performed by personnel other than those who are trained to maintain the particular equipment is considered user servicing. Some examples of user servicing are:

- a) The attachment of accessories by means of attachment plugs and receptacles or by means of other separable connectors;
- b) The changing of magnetic, electronic (USB sticks, flash memory, etc.) or optical media and the like that do not involve complicated operations;
- c) The replacement of disks, or programmable logic boards. Replacement of lamps and fuses and resetting of circuit breakers located in an operator-access area unless the lamps, fuses, or circuit breakers are marked to indicate replacement or resetting only by qualified service personnel;
- d) The marking of routine operating adjustments necessary to adapt the unit for its different intended functions;
- d) Routine cleaning of data-handling media.

2.56 WET LOCATION – Portions of an indoor installation where occasional or continuous exposure to water (for example: mist, spray, cutting jet) or other liquids is anticipated.

3 Components

3.1 Except as indicated in [3.2](#), a component of a product covered by this standard shall comply with the requirements for that component. See Appendix [A](#) for a list of standards covering components generally used in the products covered by this standard.

3.2 A component is not required to comply with a specific requirement that:

- a) Involves a feature or characteristic not required in the application of the component in the product covered by this standard, or
- b) Is superseded by a requirement in this standard.

3.3 A component shall be used in accordance with its rating established for the intended conditions of use.

3.4 Specific components are incomplete in construction features or restricted in performance capabilities. Such components are intended for use only under limited conditions, such as certain temperatures not exceeding specified limits, and shall be used only under those specific conditions.

4 Units of Measurement

4.1 Values stated without parentheses are the requirement. Values in parentheses are explanatory or approximate information.

4.2 Unless indicated otherwise, all voltage and current values are nominal rms values.

5 Undated References

5.1 Any undated reference to a code or standard appearing in the requirements of this standard shall be interpreted as referring to the latest edition of that code or standard.

CONSTRUCTION

6 General

6.1 Robotic equipment shall employ materials that are acceptable for the application and shall be made and finished with the degree of uniformity and grade of workmanship practicable in a well-equipped factory.

7 Frame and Enclosure

7.1 General

7.1.1 Robotic equipment shall be constructed and assembled so that it will have the strength and rigidity necessary to resist the abuses and the environment to which it is likely or intended to be subjected, without increasing the risk of fire, electric shock, or injury to persons due to total or partial collapse resulting in a reduction of spacings, loosening or displacement of parts, or other serious defects. Examples of intended environment, in addition to normal use, may include water spray, water cutting, hosedown (cleaning), oil, noncorrosive liquids, corrosive liquids and gases, dust, and the like. See Robots Intended for Use in Water Environments, Section [48](#), Enclosure Test, Section [76](#), and Gasket Tests, Section [78](#) for selected tests.

7.2 Cast metal

7.2.1 A cast-metal enclosure shall be at least 3.2 mm (1/8 in) thick at every point, more than 3.2 mm (1/8 in) thick at reinforcing ribs and door edges, and at least 6.4 mm (1/4 in) thick at tapped holes for conduit.

Exception: Other than at plain or threaded conduit holes, malleable iron and die-cast or permanent mold cast aluminum, brass, bronze, or zinc shall be:

a) At least 2.4 mm (3/32 in) thick for an area greater than 155 cm² (24 in²) or having any dimension more than 152 mm (6 in); and

b) At least 1.6 mm (1/16 in) thick for an area of 155 cm² (24 in²) or less having no dimension more than 152 mm (6 in). The area considered may be bounded by reinforcing ribs subdividing a larger area.

7.3 Sheet metal

7.3.1 The thickness of a sheet-metal enclosure shall not be less than that specified in [Table 7.1](#) and [Table 7.2](#), except that at points to which a wiring system is to be connected, uncoated steel shall be at least 0.81 mm (0.032 in) thick, zinc-coated steel at least 0.86 mm (0.034 in) thick, and nonferrous metal at least 1.14 mm (0.045 in) thick.

Exception: Enclosure thickness at points other than where a wiring system is to be connected need not comply with these requirements if the enclosure complies with the requirements in the Compression Test and Deflection Test in the Standard for Enclosures for Electrical Equipment, Non-Environmental Considerations, UL 50.

Table 7.1
Thickness of sheet metal for enclosures – carbon steel or stainless steel

Without supporting frame ^a		With supporting frame or equivalent reinforcing ^a				Minimum thickness					
Maximum width ^b		Maximum length ^c		Maximum width ^b		Maximum length		Uncoated		Metal coated	
cm	(in)	cm	(in)	cm	(in)	cm	(in)	mm	(in)	mm	(in)
10.2	(4.0)	Not limited		15.9	(6.25)	Not limited		0.51	(0.020) ^d	0.58	(0.023) ^d
12.1	(4.75)	14.6	(5.75)	17.1	(6.75)	21.0	(8.25)				
15.2	(6.0)	Not limited		24.1	(9.5)	Not limited		0.66	(0.026) ^d	0.74	(0.029) ^d
17.8	(7.0)	22.2	(8.75)	25.4	(10.0)	31.8	(12.5)				
20.3	(8.0)	Not limited		30.5	(12.0)	Not limited		0.81	(0.032)	0.86	(0.034)
22.9	(9.0)	29.2	(11.5)	33.0	(13.0)	40.6	(16.0)				
31.8	(12.5)	Not limited		49.5	(19.5)	Not limited		1.07	(0.042)	1.14	(0.045)
35.6	(14.0)	45.7	(18.0)	53.3	(21.0)	63.5	(25.0)				
45.7	(18.0)	Not limited		68.6	(27.0)	Not limited		1.35	(0.053)	1.42	(0.056)
50.8	(20.0)	63.5	(25.0)	73.7	(29.0)	91.4	(36.0)				
55.9	(22.0)	Not limited		83.8	(33.0)	Not limited		1.52	(0.060)	1.60	(0.063)
63.5	(25.0)	78.7	(31.0)	88.9	(35.0)	109.2	(43.0)				
63.5	(25.0)	Not limited		99.1	(39.0)	Not limited		1.70	(0.067)	1.78	(0.070)
73.7	(29.0)	91.4	(36.0)	104.1	(41.0)	129.5	(51.0)				
83.8	(33.0)	Not limited		129.5	(51.0)	Not limited		2.03	(0.080)	2.13	(0.084)
96.5	(38.0)	119.4	(47.0)	137.2	(54.0)	167.6	(66.0)				
106.7	(42.0)	Not limited		162.6	(64.0)	Not limited		2.36	(0.093)	2.46	(0.097)
119.4	(47.0)	149.9	(59.0)	172.7	(68.0)	213.4	(84.0)				
132.1	(52.0)	Not limited		203.2	(80.0)	Not limited		2.74	(0.108)	2.82	(0.111)
152.4	(60.0)	188.0	(74.0)	213.4	(84.0)	261.6	(103.0)				
160.0	(63.0)	Not limited		246.4	(97.0)	Not limited		3.12	(0.123)	3.20	(0.126)

Table 7.1 Continued on Next Page