



# UL 1686

## STANDARD FOR SAFETY

### Pin and Sleeve Configurations

[ULNORM.COM](https://www.ulnorm.com) : Click to view the full PDF of UL 1686 2023

[ULNORM.COM](https://ulnorm.com) : Click to view the full PDF of UL 1686 2023

UL Standard for Safety for Pin and Sleeve Configurations, UL 1686

Fifth Edition, Dated September 5, 2023

### **Summary of Topics**

***This Fifth new of ANSI/UL 1686 dated September 5, 2023 is being issued as a first time Trinational Standard with ANCE and CSA.***

The requirements are substantially in accordance with Proposal(s) on this subject dated January 13, 2023 and April 28, 2023.

All rights reserved. No part of this publication may be reproduced, stored in a retrieval system, or transmitted in any form by any means, electronic, mechanical photocopying, recording, or otherwise without prior permission of ULSE Inc. (ULSE).

ULSE provides this Standard "as is" without warranty of any kind, either expressed or implied, including but not limited to, the implied warranties of merchantability or fitness for any purpose.

In no event will ULSE be liable for any special, incidental, consequential, indirect or similar damages, including loss of profits, lost savings, loss of data, or any other damages arising out of the use of or the inability to use this Standard, even if ULSE or an authorized ULSE representative has been advised of the possibility of such damage. In no event shall ULSE's liability for any damage ever exceed the price paid for this Standard, regardless of the form of the claim.

Users of the electronic versions of UL's Standards for Safety agree to defend, indemnify, and hold ULSE harmless from and against any loss, expense, liability, damage, claim, or judgment (including reasonable attorney's fees) resulting from any error or deviation introduced while purchaser is storing an electronic Standard on the purchaser's computer system.

ULNORM.COM : Click to view the full PDF of UL 1686 2023

No Text on This Page

ULNORM.COM : Click to view the full PDF of UL 1686 2023



Association of Standardization and Certification  
NMX-J-864-ANCE-2023  
First Edition



CSA Group  
CSA C22.2 No. 182.6:23  
First Edition



ULSE Inc.  
UL 1686  
Fifth Edition

## Pin and Sleeve Configurations

September 5, 2023

ULNORM.COM : Click to view the full PDF of UL 1686 2023



ANSI/UL 1686-2023



## Commitment for Amendments

This standard is issued jointly by the Association of Standardization and Certification (ANCE), the Canadian Standards Association (operating as "CSA Group"), and ULSE Inc. (ULSE). Comments or proposals for revisions on any part of the standard may be submitted to ANCE, CSA Group, or ULSE at anytime. Revisions to this standard will be made only after processing according to the standards development procedures of ANCE, CSA Group, and ULSE. CSA Group and ULSE will issue revisions to this standard by means of a new edition or revised or additional pages bearing their date of issue. ANCE will incorporate the same revisions into a new edition of the standard bearing the same date of issue as the CSA Group and ULSE pages.

---

## Copyright © 2023 ANCE

Rights reserved in favor of ANCE.

---

## ISBN 978-1-4883-4493-0 © 2023 Canadian Standards Association

All rights reserved. No part of this publication may be reproduced in any form whatsoever without the prior permission of the publisher.

This Standard is subject to review within five years from the date of publication, and suggestions for its improvement will be referred to the appropriate committee. To submit a proposal for change, please send the following information to [inquiries@csagroup.org](mailto:inquiries@csagroup.org) and include "Proposal for change" in the subject line: Standard designation (number); relevant clause, table, and/or figure number; wording of the proposed change; and rationale for the change.

To purchase CSA Group Standards and related publications, visit CSA Group's Online Store at [www.csagroup.org/store/](http://www.csagroup.org/store/) or call toll-free 1-800-463-6727 or 416-747-4044.

---

## Copyright © 2023 ULSE INC.

Our Standards for Safety are copyrighted by ULSE Inc. Neither a printed nor electronic copy of a Standard should be altered in any way. All of our Standards and all copyrights, ownerships, and rights regarding those Standards shall remain the sole and exclusive property of ULSE Inc.

This ANSI/UL Standard for Safety consists of the First Edition. The most recent designation of ANSI/UL 1686 as an American National Standard (ANSI) occurred on September 5, 2023. ANSI approval for a standard does not include the Cover Page, Transmittal Pages, Title Page (front and back), or the Preface.

Comments or proposals for revisions on any part of the Standard may be submitted to ULSE at any time. Proposals should be submitted via a Proposal Request in the Collaborative Standards Development System (CSDS) at <https://csds.ul.com>.

For information on ULSE Standards, visit <http://www.shopulstandards.com>, call toll free 1-888-853-3503 or email us at [ClientService@shopULStandards.com](mailto:ClientService@shopULStandards.com).

---

**CONTENTS**

**Preface ..... 5**

**INTRODUCTION**

1 Scope .....7  
2 Referenced Publications .....7  
3 Units of Measurement .....7  
4 General .....7

**CONFIGURATIONS**

C1 Configurations .....8  
C2 Configurations .....19  
C3 Configurations .....96  
C4 Configurations .....115  
C5 Specific Configurations .....122

**ANNEX A (Informative) – Equivalent Tables in Inches**

ULNORM.COM : Click to view the full PDF of UL 1686 2023

No Text on This Page

ULNORM.COM : Click to view the full PDF of UL 1686 2023

## Preface

This is the harmonized ANCE, CSA Group, and ULSE standard for Pin and Sleeve Configurations. It is the first edition of NMX-J-864-ANCE, the first edition of CSA C22.2 No. 182.6, and the fifth edition of UL 1686. This edition of UL 1686 supersedes the previous edition published August 17, 2012.

This harmonized standard was prepared by the Association of Standardization and Certification (ANCE), CSA Group, and ULSE. The efforts and support of the Technical Harmonization Subcommittee 23H under CANENA on the Harmonization of Electrotechnical Standards of the Nations of the Americas (CANENA), are gratefully acknowledged.

This Standard is considered suitable for use for conformity assessment within the stated scope of the Standard.

The present Mexican standard was developed by the CT 23 Electrical Accessories (Wiring Devices) from the Comité de Normalización de la Asociación de Normalización y Certificación A.C., CONANCE, with the collaboration of the electrical manufacturers and users.

This standard was reviewed by the CSA Integrated Committee on Wiring Devices, under the jurisdiction of the CSA Technical Committee on Wiring Products and the CSA Strategic Steering Committee on Requirements for Electrical Safety (SCORES), and has been formally approved by the CSA Technical Committee. This standard has been developed in compliance with the Standards Council of Canada requirements for National Standards of Canada. It has been published as a National Standard of Canada by CSA Group.

## Application of Standard

Where reference is made to a specific number of samples to be tested, the specified number is to be considered a minimum quantity.

Note: Although the intended primary application of this standard is stated in its scope, it is important to note that it remains the responsibility of the users of the standard to judge its suitability for their particular purpose.

## Level of harmonization

This standard is published as an equivalent standard for ANCE, CSA Group, and ULSE.

An equivalent standard is a standard that is substantially the same in technical content, except as follows: Technical national differences are allowed for codes and governmental regulations as well as those recognized as being in accordance with NAFTA Article 905, for example, because of fundamental climatic, geographical, technological, or infrastructural factors, scientific justification, or the level of protection that the country considers appropriate. Presentation is word for word except for editorial changes.

## Interpretations

The interpretation by the standards development organization of an identical or equivalent standard is based on the literal text to determine compliance with the standard in accordance with the procedural rules of the standards development organization. If more than one interpretation of the literal text has been identified, a revision is to be proposed as soon as possible to each of the standards development organizations to more accurately reflect the intent.

No Text on This Page

ULNORM.COM : Click to view the full PDF of UL 1686 2023

## INTRODUCTION

### 1 Scope

1.1 These configurations cover attachment plugs, receptacles, and cord connectors, for use in accordance with the National Electrical Code (NEC), NFPA 70 and CSA C22.1, Canadian Electrical Code, Part I (CE Code).

1.2 These configurations do not cover devices rated at more than 800 A or for more than 600 V.

### 2 Referenced Publications

2.1 Any undated reference to a code or standard appearing in the requirements of this Standard shall be interpreted as referring to the latest edition of that code or standard.

2.2 The following standards are referenced in this Standard, and portions of these referenced standards may be essential for compliance.

CSA C22.1, *Canadian Electrical Code (CE Code)*

IEC 60309-2, *Plugs, Fixed or Portable Socket-Outlets and Appliance Inlets for Industrial Purposes – Part 2: Dimensional Compatibility Requirements for Pin and Contact-Tube Accessories*

NFPA 70, *National Electrical Code*

### 3 Units of Measurement

3.1 The values given in SI (metric) units shall be normative. Any other values given shall be for information purposes only.

### 4 General

4.1 The information given in (a) – (h) applies to each configuration in Sections [C1](#) – [C5](#).

a) All dimensions are in inches. Metric values were derived by converting from English imperial units given in Annex [A](#). If reference dimensions are needed, the metric dimensions shall be considered extended to be 3 decimal places from the Imperial units given in Annex [A](#).

b) Decimal dimensions without tolerances shall be subject to a 0.0127 cm ( $\pm 0.005$  inch) tolerance. When metric values are used, they have been derived by converting from imperial units given in this standard. If a reference dimension is needed, the metric dimension shall be extended to 3 decimal places.

c) Angular dimensions without tolerances shall be subject to a  $\pm 1/2$  degree tolerance.

d) Where two values are given for the same dimension, the larger is the maximum value and the smaller the minimum value.

e) Leading edges of pins and sleeves shall be free of burrs and sharp edges.

f) A contour, face dimension, yoke construction, or mounting ears and dimensions for any receptacle construction that is shown depicts an acceptable construction; other constructions may also be acceptable if tested and found to be equivalent.

g) The relationship of recessing of contacts, or internal construction in a receptacle that is shown depicts an acceptable construction; other constructions may also be acceptable if tested and found to be equivalent.

h) Terminal identification shall comply with the following:

- 1) The grounded terminal shall be identified in the Figures by the letter "W".
- 2) The grounding terminal shall be identified in the Figures by the letter "G".

## CONFIGURATIONS

### C1 Configurations

1. Q is the allowable distance measured from the male contact tip to a plane perpendicular to the longitudinal axis where initial electrical engagement with the sleeve contact takes place.
2. The design of the pins shall provide a means of maintaining electrical contact force to their respective sleeve contacts.
3. The design of the ground springs shall provide a means of maintaining electrical contact with the plug sleeve when the plug is mated with the receptacle.
4. Connectors shall be rated for use in ordinary locations only.
5. Receptacles may be rated for use in Hazardous Locations.
6. Plugs shall be rated for use in Hazardous Locations.
7. Inlets shall be rated for use in ordinary locations only.

ULNORM.COM : Click to view the full PDF of UL 1686:2023

Figure C1.1  
Receptacle and Connectors

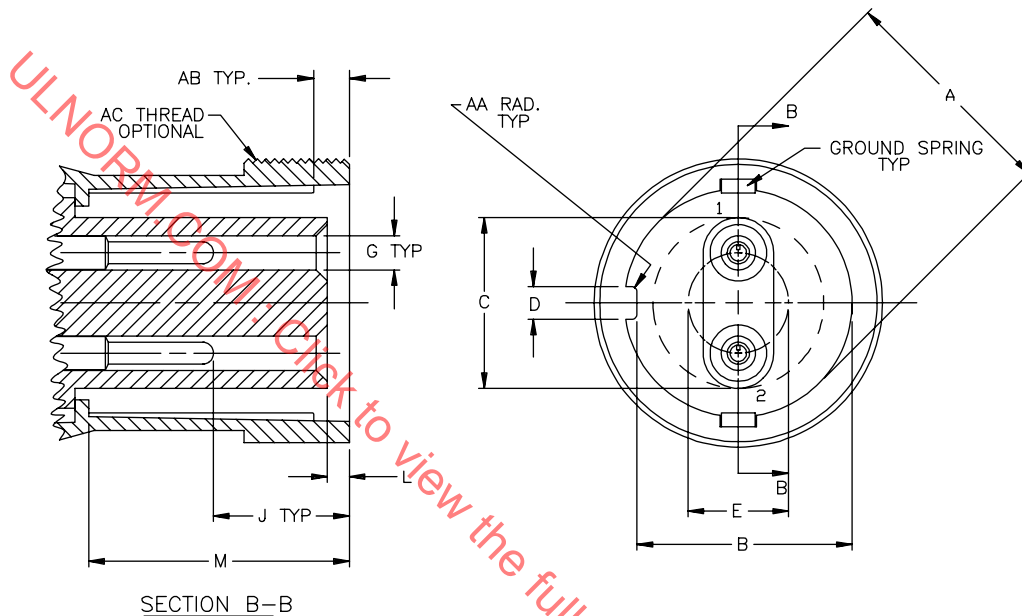

See note 1, 2, 3, 4 and 5.

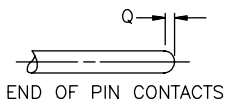

STYLE	TYPE	AMP RATING	A (∅)	B	C (∅)	D	E (∅)	G (∅)	J	L	M	Q	AA	AB	AC
1	2P	30	1.929 1.865	1.818 1.750	1.440 1.145	.198 .148	.568 .557	.266 .258	1.115 1.005	.275 .225	1.734 MIN	.120 .080	.104 .026	.750 .250	2 9/16-14 UNS-2B
1	2P	60	2.359 2.240	2.219 2.116	1.600 1.515	.385 .314	.855 .830	.392 .361	1.609 1.465	.359 .214	2.891 MIN	.140 .100	.130 .045	1.500 .250	2 15/16-14 UNS-2B
1	2P	100	2.606 2.490	2.451 2.368	2.015 1.875	.382 .300	1.036 1.025	.485 .447	1.995 1.907	.300 .205	3.547 MIN	.175 .135	.130 .045	1.500 .250	3 3/16-14 UNS-2B

SM802

F, H, I, K, N-P, R-Z NOT USED

See notes 6 and 7.

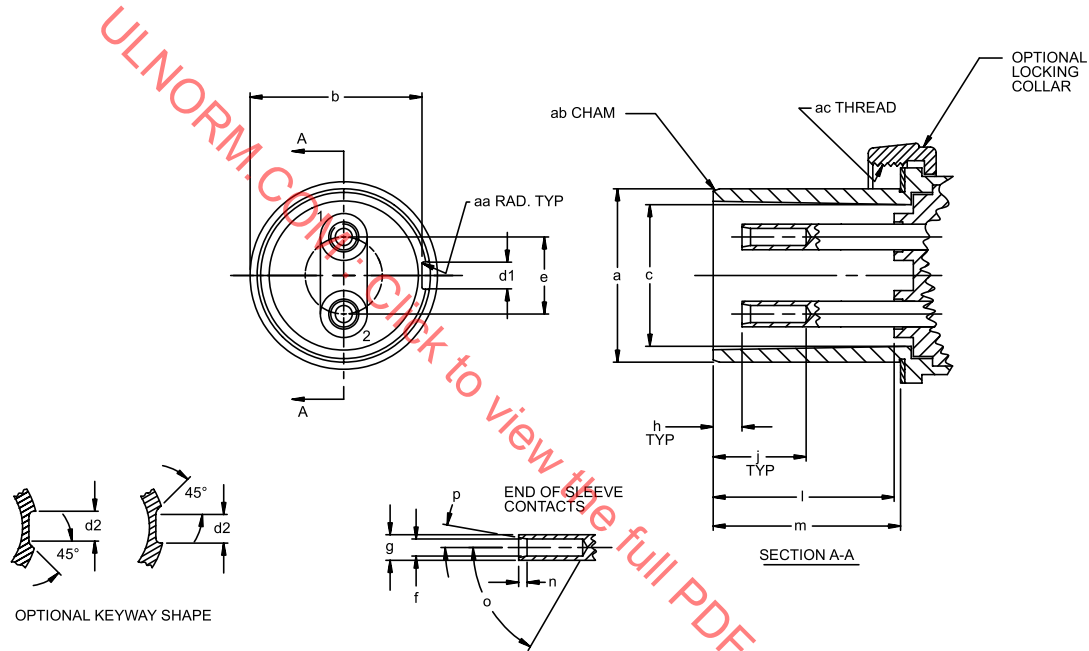

Figure C1.2  
Plugs and Inlets

STYLE	TYPE	AMP RATING	a (Ø)	b	c (Ø)	d1	d2	e (Ø)	f (Ø)	g (Ø)	h	j	l	m	n	o	p	aa	ab	ac
1	2P	30	1.865 1.848	1.770 1.745	1.540 1.460	.220 .199	.205 .195	.568 .557	.191 .186	.253 .247	.095 .005	.922 .640	1.435 MIN	1.655 1.621	.021 .000	60.5° 58.5°	45.5° 0.0°	.107 .011	.05 X 20° .10 X 40°	2 9/16-14 UNS-2B
1	2P	60	2.239 2.220	2.114 2.079	1.890 1.670	.400 .385	.360 .340	.855 .830	.253 .249	.378 .365	.530 .383	1.415 1.300	2.615 MIN	2.765 2.672	.130 .058	60.5° 58.5°	15.5° 8.0°	.100 .020	.05 X 20° .10 X 40°	2 15/16-14 UNS-2B
1	2P	100	2.485 2.460	2.365 2.338	2.110 2.030	.420 .385	.360 .340	1.036 1.025	.315 .311	.442 .432	.495 .395	1.612 1.512	3.305 MIN	3.485 3.422	.161 .058	60.5° 58.5°	13.5° 8.0°	.110 .026	.05 X 20° .10 X 40°	3 3/16-14 UNS-2B

SM803

i, k, q-z NOT USED

Figure C1.3  
Receptacles and Connectors

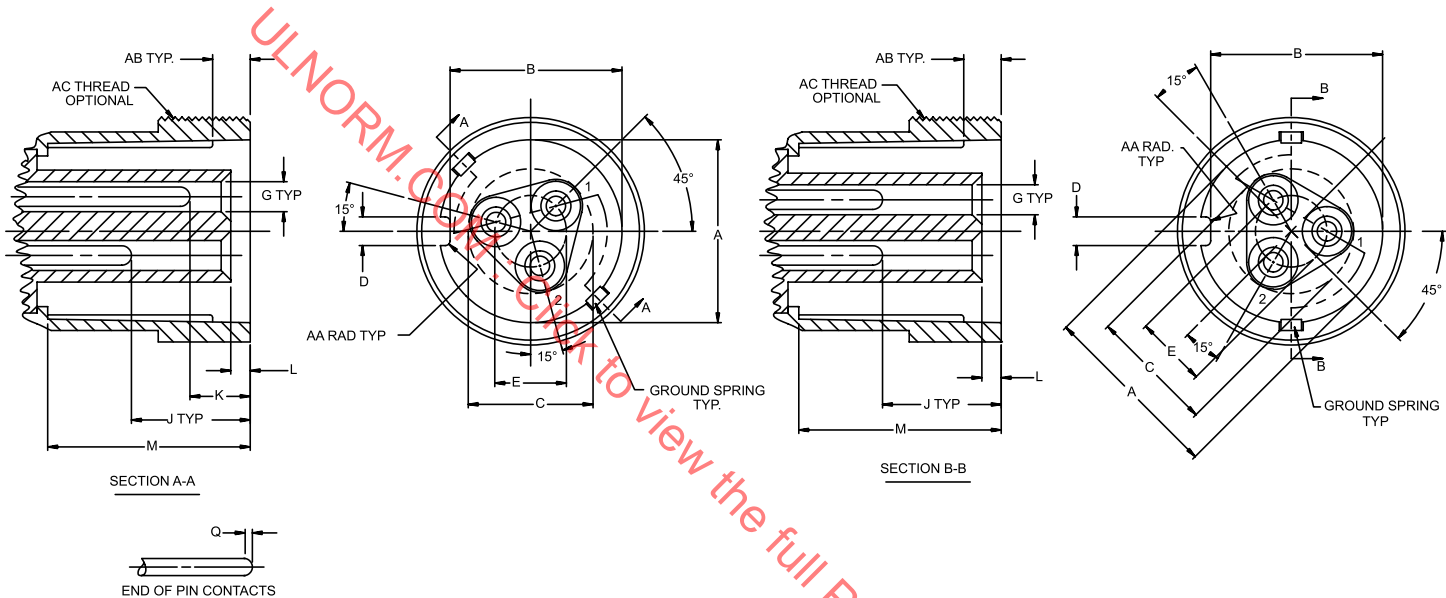

STYLE	TYPE	AMP RATING	A (Ø)	B	C (Ø)	D	E (Ø)	G (Ø)	J	K	L	M	Q	AA	AB	AC
1	3P	30	1.929 1.865	1.818 1.750	1.440 1.145	.198 .148	.760 .740	.266 .258	1.115 1.005	—	.275 .225	1.734 MIN	.120 .080	.104 .026	.750 .250	2 9/16-14 UNS-2B
2	2P+G	30	1.929 1.865	1.818 1.750	1.440 1.145	.198 .148	.760 .740	.266 .258	1.115 1.005	.375 .280	.275 .225	1.734 MIN	.120 .080	.104 .026	.750 .250	2 9/16-14 UNS-2B
1	3P	100	2.606 2.490	2.451 2.368	2.015 1.875	.382 .300	1.044 1.022	.485 .447	1.995 1.907	—	.300 .205	3.547 MIN	.175 .135	.130 .045	1.500 .250	3 3/16-14 UNS-2B
2	2P+G	100	2.606 2.490	2.451 2.368	2.015 1.875	.382 .300	1.044 1.022	.485 .447	1.995 1.907	1.100 .875	.300 .205	3.547 MIN	.175 .135	.130 .045	1.500 .250	3 3/16-14 UNS-2B

F, H, I, N-P, R-Z NOT USED

SM804

See notes 1, 2, 3, 4 and 5.

See notes 6 and 7.

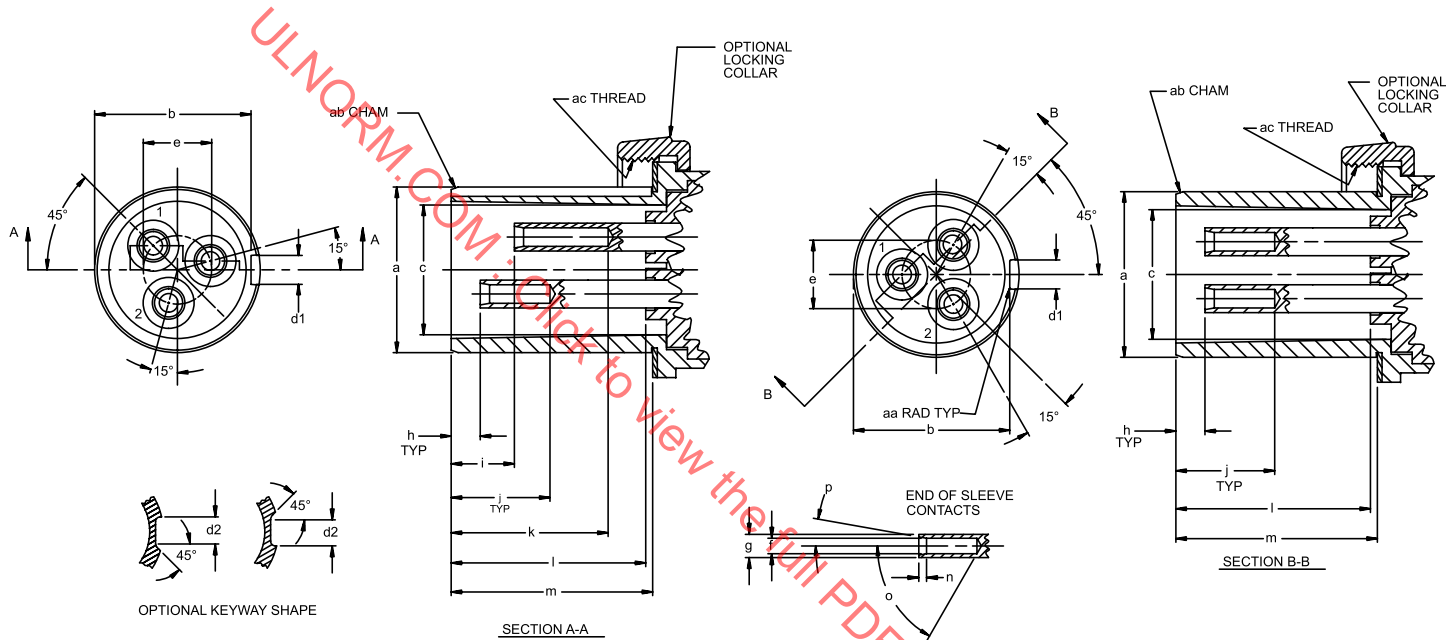

Figure C1.4  
Plugs and Inlets

STYLE	TYPE	AMP RATING	a (Ø)	b	c (Ø)	d1	d2	e (Ø)	f (Ø)	g (Ø)	h	i	j	k	l	m	n	o	p	aa	ab	ac
1	3P	30	1.865 1.848	1.770 1.745	1.540 1.460	.220 .199	.205 .195	.760 .740	.191 .186	.253 .247	.095 .005	—	.922 .640	—	1.435 MIN	1.655 1.621	.021 .000	60.5° 58.5°	45.5° 0.0°	.107 .011	.05 X 20° .10 X 40°	2 9/16-14 UNS-2B
2	2P+G	30	1.865 1.848	1.770 1.745	1.540 1.460	.220 .199	.205 .195	.760 .740	.191 .186	.253 .247	.095 .005	.445 .355	.922 .640	1.590 1.435	1.435 MIN	1.655 1.621	.021 .000	60.5° 58.5°	45.5° 0.0°	.107 .011	.05 X 20° .10 X 40°	2 9/16-14 UNS-2B
1	3P	100	2.485 2.460	2.365 2.338	2.110 2.030	.420 .385	.360 .340	1.044 1.022	.315 .311	.442 .432	.495 .395	—	1.612 1.512	—	3.305 MIN	3.485 3.422	.161 .058	60.5° 58.5°	13.5° 8.0°	.110 .026	.05 X 20° .10 X 40°	3 3/16-14 UNS-2B
2	2P+G	100	2.485 2.460	2.365 2.338	2.110 2.030	.420 .385	.360 .340	1.044 1.022	.315 .311	.442 .432	.495 .395	.985 .873	1.612 1.512	2.976 2.545	3.305 MIN	3.485 3.422	.161 .058	60.5° 58.5°	13.5° 8.0°	.110 .026	.05 X 20° .10 X 40°	3 3/16-14 UNS-2B

SM805

q-z NOT USED

Figure C1.5  
Receptacles and Connectors

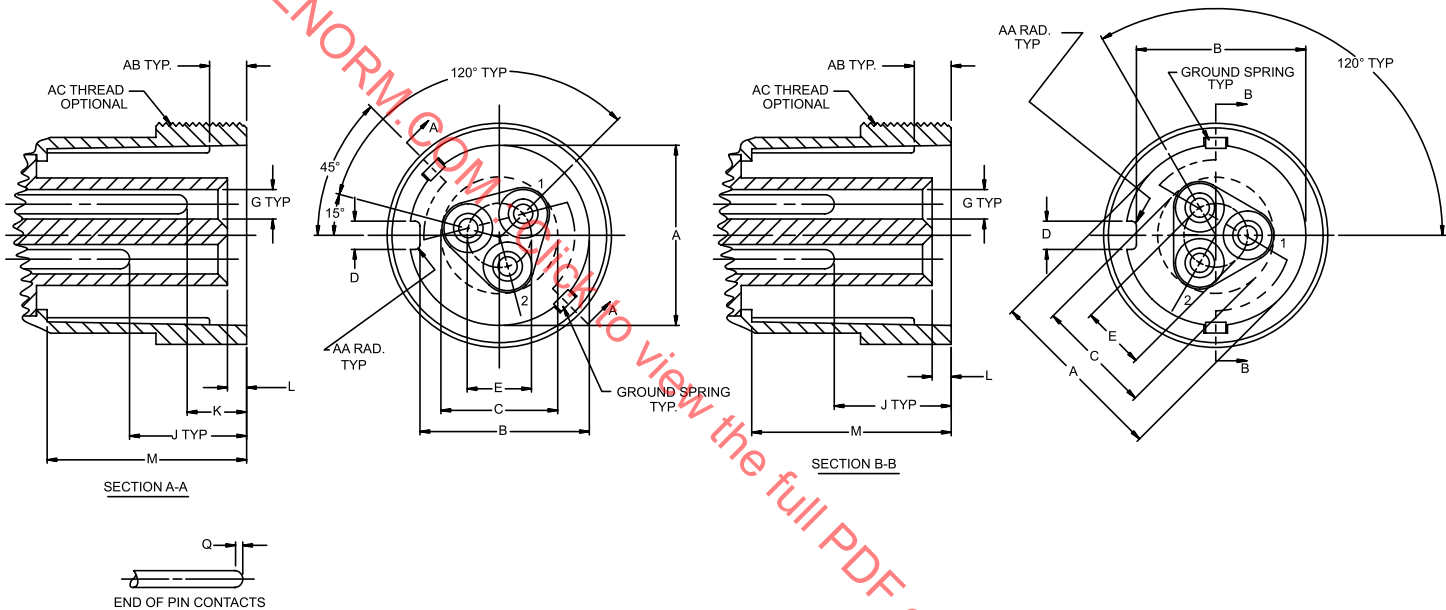

STYLE	TYPE	AMP RATING	A (Ø)	B	C (Ø)	D	E (Ø)	G (Ø)	J	K	L	M	Q	AA	AB	AC
1	3P	60	2.359 2.240	2.219 2.116	1.600 1.515	.385 .314	.886 .866	.392 .381	1.609 1.465	—	.359 .214	2.891 MIN	.100 .140	.130 .045	1.500 .250	2 15/16-14 UNS-2B
2	2P + G	60	2.359 2.240	2.219 2.116	1.600 1.515	.385 .314	.886 .866	.392 .381	1.609 1.465	.859 .755	.359 .214	2.891 MIN	.100 .140	.130 .045	1.500 .250	2 15/16-14 UNS-2B

SM806

F, H, I, N-P, R-Z NOT USED

See notes 1, 2, 3, 4 and 5.

See notes 6 and 7.

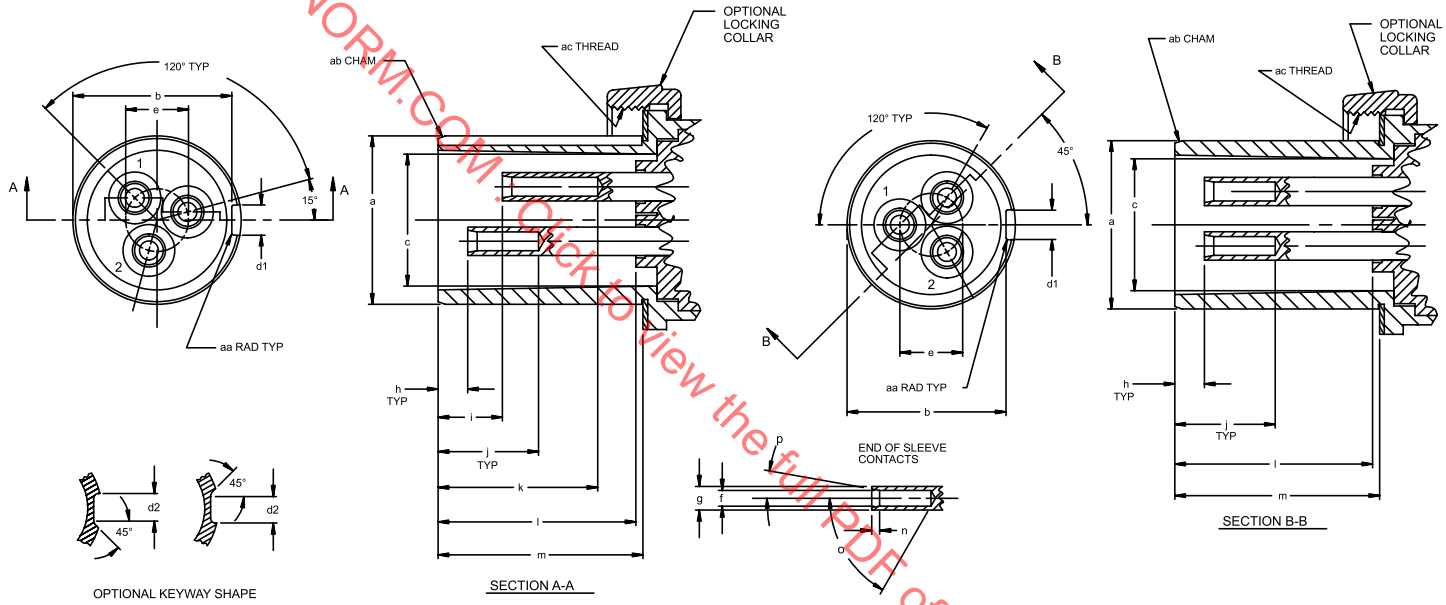

STYLE	TYPE	AMP RATING	a (Ø)	b	c (Ø)	d1	d2	e (Ø)	f (Ø)	g (Ø)	h	i	j	k	l	m	n	o	p	aa	ab	ac
1	3P	60	2.239 2.220	2.114 2.079	1.890 1.670	.400 .385	.360 .340	.886 .866	.253 .249	.378 .365	.530 .383	—	1.415 1.300	—	2.615 MIN	2.765 2.672	.130 .058	60.5° 58.5°	15.5° 8.0°	.100 .020	.05 X 20° .10 X 40°	2 15/16-14 UNS-2B
2	2P+G	60	2.239 2.220	2.114 2.079	1.890 1.670	.400 .385	.360 .340	.886 .866	.253 .249	.378 .365	.530 .383	.977 .843	1.415 1.300	2.276 2.050	2.615 MIN	2.765 2.672	.130 .058	60.5° 58.5°	15.5° 8.0°	.100 .020	.05 X 20° .10 X 40°	2 15/16-14 UNS-2B

SM807A

q-z NOT USED

Figure C1.6  
Plugs and Inlets

Figure C1.7  
Receptacles and Connectors

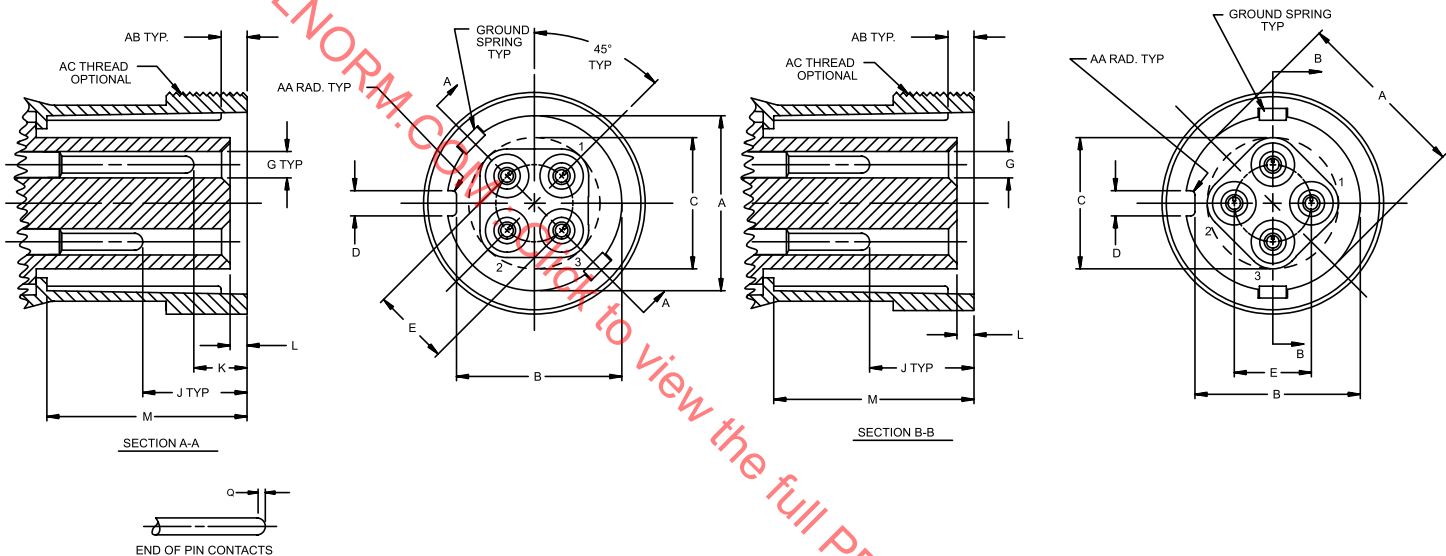

STYLE	TYPE	AMP RATING	A (Ø)	B	C (Ø)	D	E (Ø)	G (Ø)	J	K	L	M	Q	AA	AB	AC
1	4P	30	1.929 1.865	1.818 1.750	1.440 1.145	.198 .148	.755 .745	.266 .258	1.115 1.005	—	.275 .225	1.734 MIN	.120 .080	.104 .026	.750 .250	2 9/16-14 UNS-2B
2	3P + G	30	1.929 1.865	1.818 1.750	1.440 1.145	.198 .148	.755 .745	.266 .258	1.115 1.005	.375 .280	.275 .225	1.734 MIN	.120 .080	.104 .026	.750 .250	2 9/16-14 UNS-2B
1	4P	60	2.643 2.560	2.505 2.425	1.976 1.854	.385 .314	1.136 1.120	.392 .381	1.609 1.465	—	.359 .214	2.891 MIN	.140 .100	.130 .045	1.500 .250	3 1/4-14 UNS-2B
2	3P + G	60	2.643 2.560	2.505 2.425	1.976 1.854	.385 .314	1.136 1.120	.392 .381	1.609 1.465	.859 .755	.359 .214	2.891 MIN	.140 .100	.130 .045	1.500 .250	3 1/4-14 UNS-2B

SM808A

F, H, I, N-P, R-Z NOT USED

See notes 1, 2, 3, 4 and 5.

See notes 6 and 7.

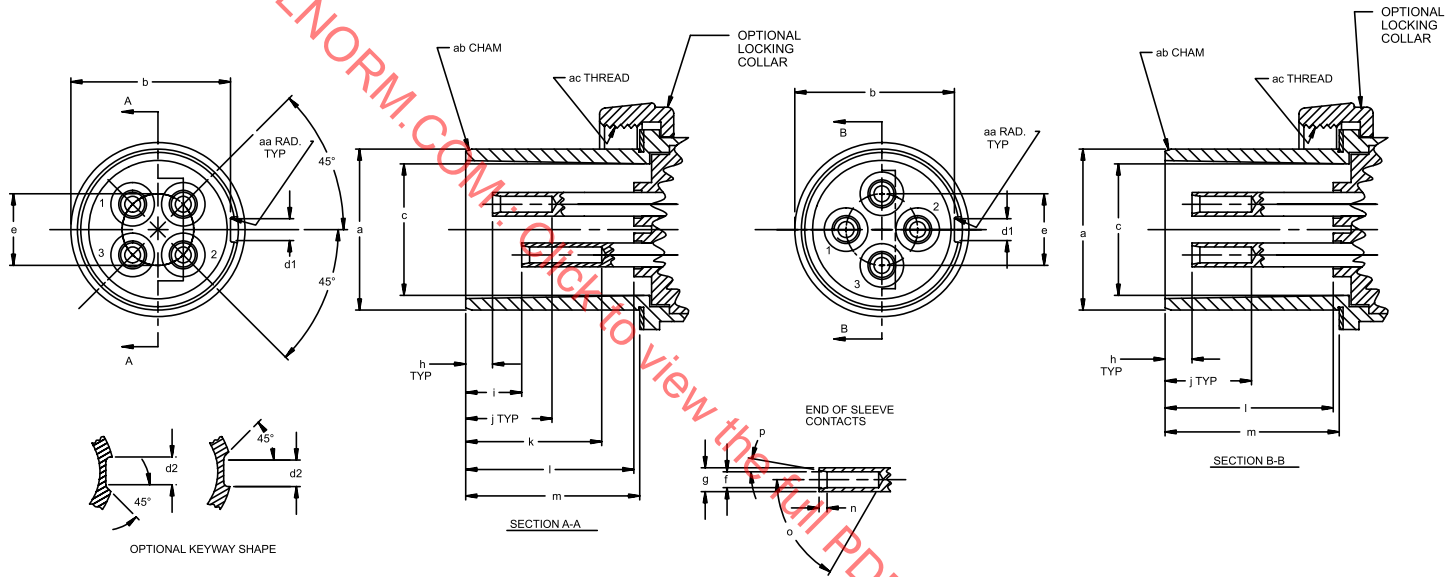

STYLE	TYPE	AMP RATING	a (Ø)	b	c (Ø)	d1	d2	e (Ø)	f (Ø)	g (Ø)	h	i	j	k	l	m	n	o	p	aa	ab	ac
1	4P	30	1.865 1.848	1.770 1.745	1.540 1.460	.220 .199	.205 .195	.755 .745	.191 .186	.253 .247	.095 .005	—	.922 .640	—	1.435 MIN	1.655 1.621	.021 .000	60.5° 58.5°	45.5° 0.0°	.107 .011	.05 X 20° .10 X 40°	2 9/16-14 UNS-2B
2	3P + G	30	1.865 1.848	1.770 1.745	1.540 1.460	.220 .199	.205 .195	.755 .745	.191 .186	.253 .247	.095 .005	.445 .355	.922 .640	1.590 1.435	1.435 MIN	1.655 1.621	.021 .000	60.5° 58.5°	45.5° 0.0°	.107 .011	.05 X 20° .10 X 40°	2 9/16-14 UNS-2B
1	4P	60	2.552 2.510	2.423 2.400	2.172 1.982	.420 .385	.360 .340	1.136 1.120	.253 .249	.378 .365	.530 .383	—	1.415 1.300	—	2.615 MIN	2.765 2.672	.130 .058	60.5° 58.5°	15.5° 8.0°	.100 .020	.05 X 20° .10 X 40°	3 1/4-14 UNS-2B
2	3P + G	60	2.552 2.510	2.423 2.400	2.172 1.982	.420 .385	.360 .340	1.136 1.120	.253 .249	.378 .365	.530 .383	.977 .843	1.415 1.300	2.276 2.050	2.615 MIN	2.765 2.672	.130 .058	60.5° 58.5°	15.5° 8.0°	.100 .020	.05 X 20° .10 X 40°	3 1/4-14 UNS-2B

SM809A

q-z NOT USED.

Figure C1.8  
Plugs and Inlets

Figure C1.9  
Receptacles and Connectors

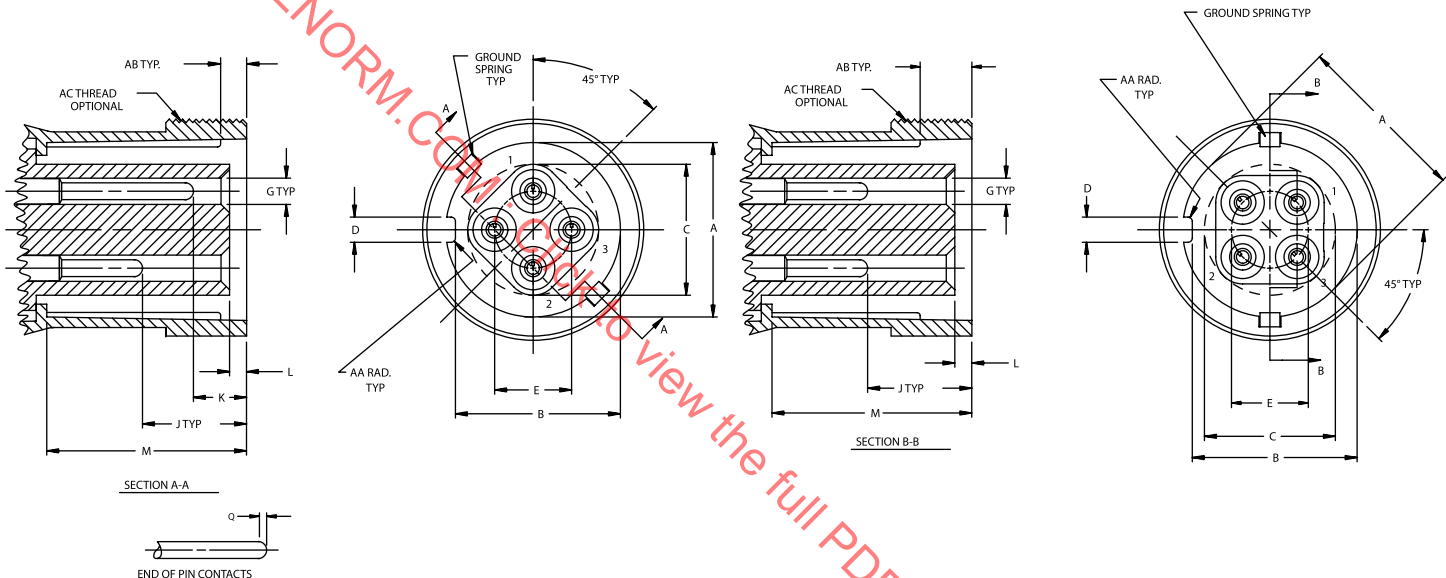

STYLE	TYPE	AMP RATING	A (Ø)	B	C (Ø)	D	E (Ø)	G (Ø)	J	K	L	M	Q	AA	AB	AC
1	4P	100	2.849 2.740	2.700 2.618	2.230 2.155	.382 .320	1.255 1.245	.485 .447	1.995 1.907	—	.300 .205	3.547 MIN	.175 .135	.130 .045	1.500 .250	3 7/16-14 UNS-2B
2	3P + G	100	2.849 2.740	2.700 2.618	2.230 2.155	.382 .320	1.255 1.245	.485 .447	1.995 1.907	1.100 .875	.300 .205	3.547 MIN	.175 .135	.130 .045	1.500 .250	3 7/16-14 UNS-2B

SM810A

F, H, I, N-P, R-Z NOT USED

See notes 1, 2, 3, 4 and 5.

ULNORM.COM To view the full PDF of UL 1686 2023

See note 6 and 7.

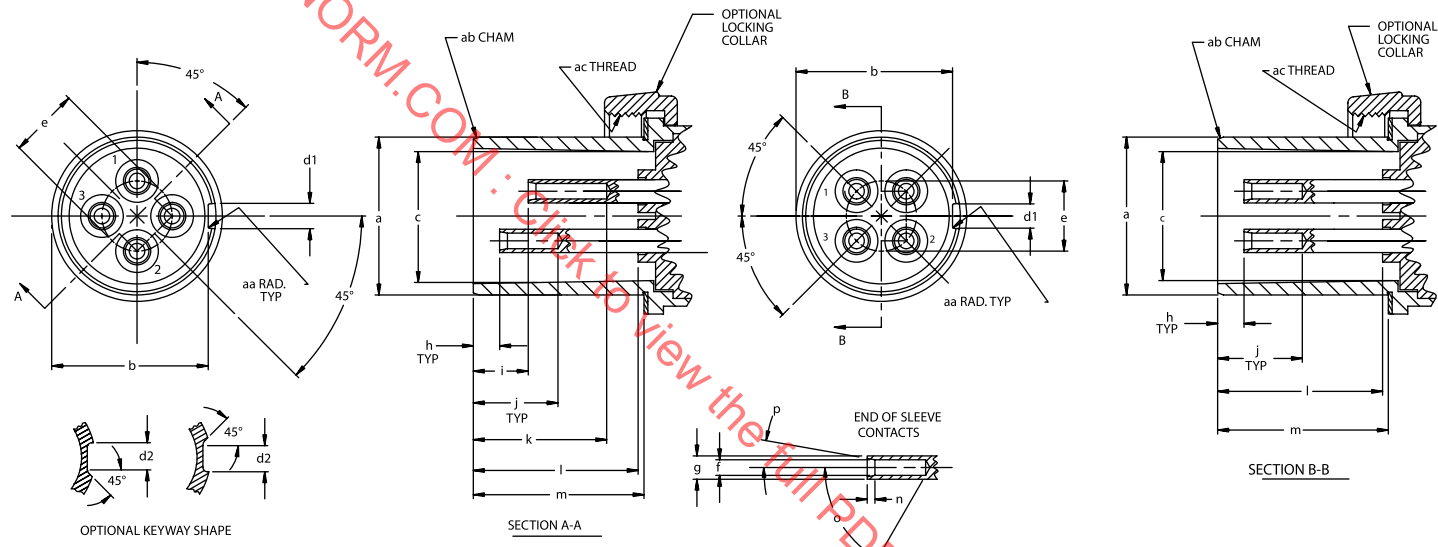

STYLE	TYPE	AMP RATING	a (Ø)	b	c (Ø)	d1	d2	e (Ø)	f (Ø)	g (Ø)	h	i	j	k	l	m	n	o	p	aa	ab	ac
1	4P	100	2.735 2.713	2.615 2.584	2.359 2.257	.420 .385	.360 .340	1.255 1.245	.315 .311	.442 .432	.495 .395		1.612 1.512		3.305 MIN	3.485 3.422	.161 .058	60.5° 58.5°	13.5° 8.0°	.110 .026	.05 X 20° .10 X 40°	3/7/16-14 UNS-2B
2	3P+G	100	2.735 2.713	2.615 2.584	2.359 2.257	.420 .385	.360 .340	1.255 1.245	.315 .311	.442 .432	.495 .395	.985 .873	1.612 1.512	2.976 2.545	3.305 MIN	3.485 3.422	.161 .058	60.5° 58.5°	13.5° 8.0°	.110 .026	.05 X 20° .10 X 40°	3/7/16-14 UNS-2B

SM811

q-z NOT USED

Figure C1.10  
Plugs and Inlets

## C2 Configurations

C2.1 [Figure C2.1](#) – [Figure C2.38](#) illustrate the configurations for plugs and inlets and for receptacles and connectors of single-rated Pin and Sleeve devices of the IEC 60309-2 type, Series II. The dimensions shown define the features which enable proper mating and mating of devices only with the same service, voltage, and amperage. The plug (or inlet) shroud shall have an external key which mates with a keyway in the receptacle (or connector) cavity. The key/keyway is shown at the bottom of each configuration. The ground contact is located from this point in 30° increments to provide discrete and predetermined contact patterns. The position of the female ground contact, when viewed with the keyway at the 6 o'clock position, is referred to as the "clock" position. There is a designated clock position for each voltage and service.

These drawings do not show locking, sealing cord grip, or envelope clearance dimensions. Additionally, the following shall apply:

- a) The main view is shown with the grounding tube or pin at the 6 o'clock position for reference only. See the rating configuration for the required positions.
- b) Holes or recesses in the frontal face, if any, other than those for contact tubes, shall not have a depth of more than 10 mm (0.394 inch).
- c) The dimension described in (b) shall not exceed the specified limit at any point over the entire depth, and shall be within the specified limits over a minimum depth of 6 mm (0.236 inch) with the exception of a maximum of:
  - 1) three cut-outs for receptacles or outlets provided with 2 poles plus ground,
  - 2) four cut-outs for receptacles or outlets provided with three poles plus ground, or
  - 3) five cut-outs for devices provided with three poles plus neutral plus ground, spaced around the circumference.
  - 4) There shall not be more than one cut-out between adjacent holes for the contact tubes and each shall not have a width exceeding 15 mm (0.590 inch) including any radii. Holes deeper than 1 mm (0.394 inch) in the area are allowed,
- d) Pin detail dimensions refer to pin diameters. The contact tubes provide contact pressure and need not be cylindrical.
- e) The bevelling of the contact tubes may be rounded off toward the internal cylindrical surface within a distance of 1-1/2 times the maximum dimension.
- f) Collars shall be provided for plugs or inlet devices having rated operating voltages exceeding 500 V.
- g) The ends of pins may be rounded off toward the external cylindrical surface within a distance of 1-1/2 times the maximum dimension.
- h) "⏏" denotes the equipment ground contact. The terminal shall be identified by the word "green", the color green, or both. The terminal may additionally be marked with the earth symbol ("⏏").
- i) N denotes the grounded line conductor contact. The terminal shall be identified by the word "white", the color white, or both. The terminal may additionally be marked with the letter "N".

(Continued)

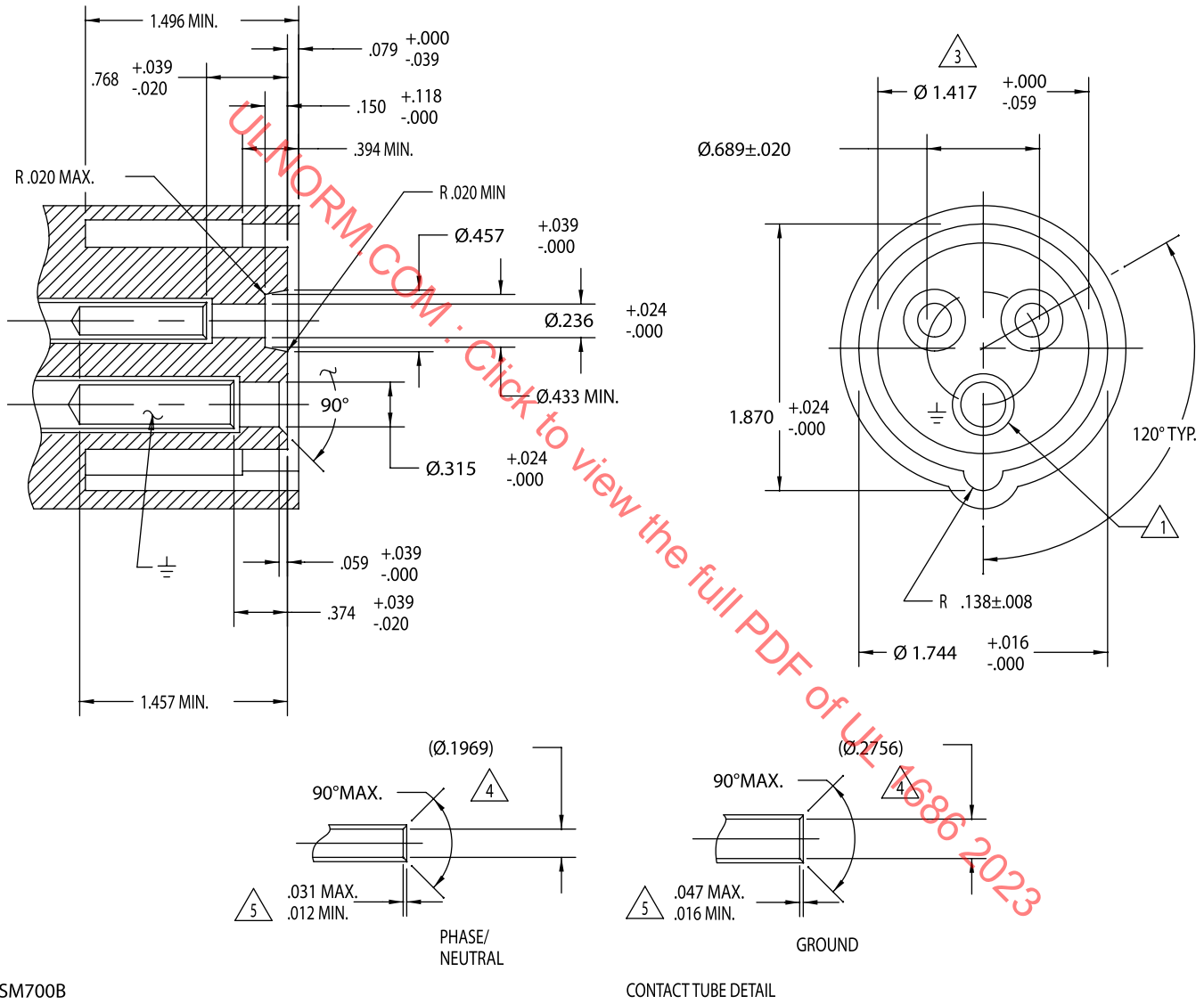

20 Ampere, 3 Wire Without Pilot  
Receptacle or Connector  
Figure C2.1

- 1. MAIN VIEW SHOWN WITH GROUND AT 6 O'CLOCK POSITION FOR REFERENCE ONLY. SEE RATING CONFIGURATION FOR RELEVANT POSITIONS.
- 2. HOLES OR RECESSES IN THE FRONTAL FACE, IF ANY, OTHER THAN THOSE FOR CONTACT TUBES, SHALL HAVE A DEPTH OF NOT MORE THAN .394 INCHES. (EXCEPTION: SEE NOTE 3)
- 3. THIS DIMENSION SHALL NOT EXCEED THE PRESCRIBED LIMIT AT ANY POINT OVER THE WHOLE DEPTH, AND SHALL BE WITHIN THE PRESCRIBED LIMITS OVER A MINIMUM DEPTH OF .236 INCHES WITH THE EXCEPTION OF A MAXIMUM OF 3 CUT-OUTS SPACED AROUND THE CIRCUMFERENCE WITH NOT MORE THAN ONE CUT-OUT BETWEEN ADJACENT HOLES FOR THE CONTACT TUBES AND EACH HAVING A WIDTH NOT EXCEEDING .590 INCHES INCLUDING ANY RADII. HOLES DEEPER THAN .394 INCHES IN THE AREA ARE ALLOWED.
- 4. DIMENSIONS REFER TO PIN DIAMETERS; THE CONTACTS TUBES NEED NOT BE CIRCULAR.
- 5. THE BEVELLING OF THE CONTACTS TUBES MAY BE ROUNDED OFF TOWARDS THE INTERNAL CYLINDRICAL SURFACE WITHIN A DISTANCE OF 1-1/2 TIMES THE MAXIMUM DIMENSION.
- 6.  $\perp$  DENOTES EQUIPMENT GROUND CONTACT. TERMINAL SHALL BE IDENTIFIED BY THE WORD "GREEN" AND/OR COLOR GREEN. TERMINAL MAY BE ADDITIONALLY IDENTIFIED BY EARTH SYMBOL ( $\perp$ ).
- 7. N DENOTES GROUNDED LINE CONDUCTOR CONTACT. TERMINAL SHALL BE IDENTIFIED BY THE WORD "WHITE" AND/OR COLOR WHITE. TERMINAL MAY BE ADDITIONALLY IDENTIFIED BY THE LETTER "N".

RATING CONFIGURATIONS  
FRONT VIEW - RECEPTACLE OR CONNECTOR

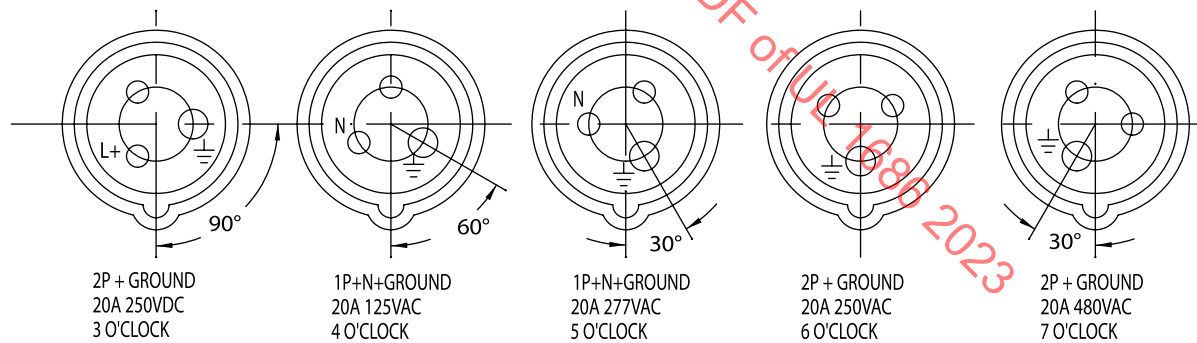

SM701A

Figure C2.1 (cont.)



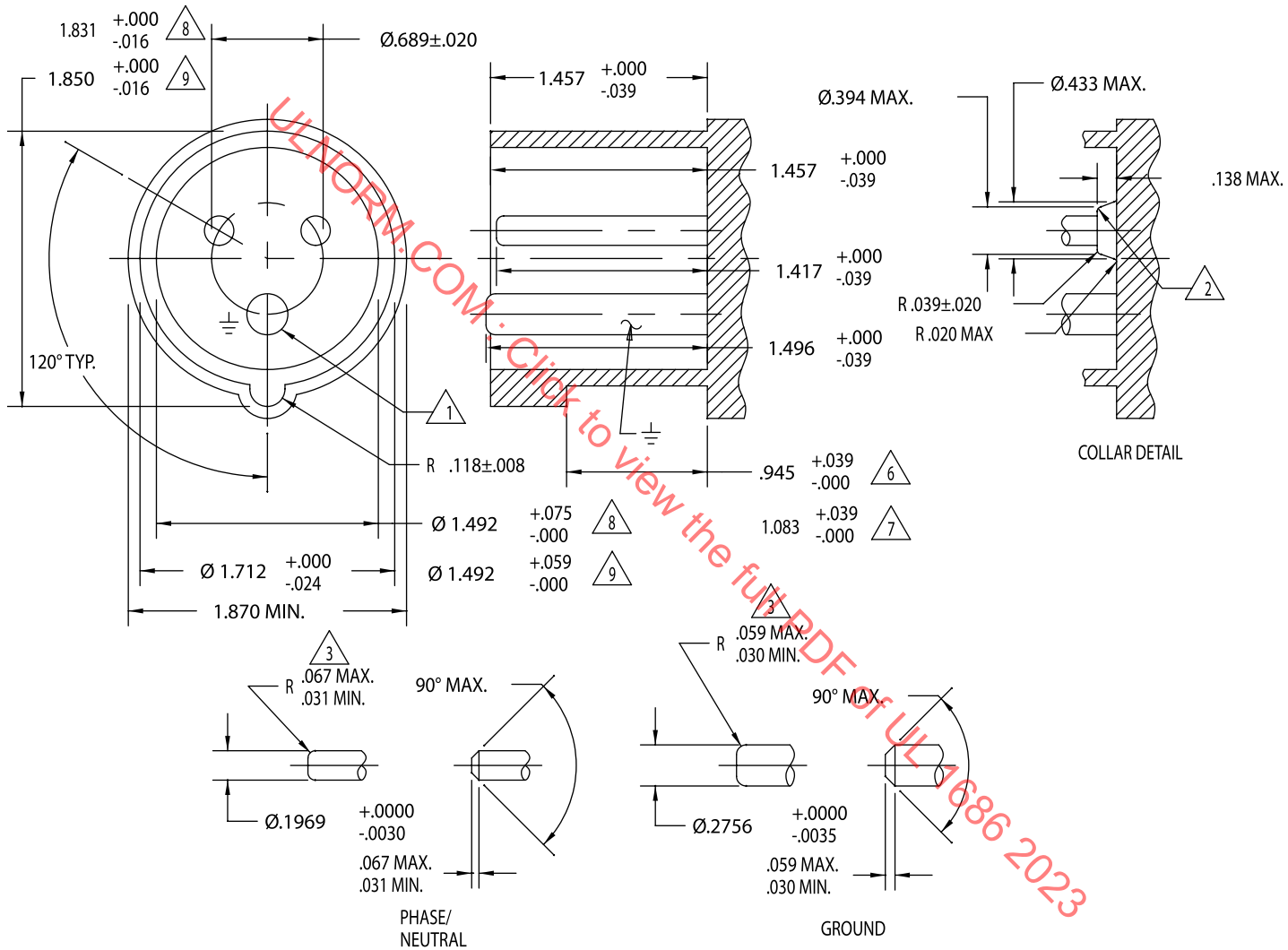



(Continued)



SM702

PIN DETAIL

Figure C2.2  
Plug or Inlet  
20 Ampere, 3 Wire Without Pilot

- 1. MAIN VIEW SHOWN WITH GROUND AT 6 O'CLOCK POSITION FOR REFERENCE ONLY. SEE RATING CONFIGURATION FOR RELEVANT POSITIONS.
- 2. COLLARS REQUIRED FOR DEVICES HAVING RATED OPERATING VOLTAGES EXCEEDING 500 V, OPTIONAL FOR OTHER DEVICES.
- 3. ENDS OF PINS MAY BE ROUNDED OFF TOWARDS THE EXTERNAL CYLINDRICAL SURFACE WITHIN A DISTANCE OF 1-1/2 TIMES OF THE MAXIMUM DIMENSION.
- 4.  DENOTES EQUIPMENT GROUND CONTACT. TERMINAL SHALL BE IDENTIFIED BY THE WORD "GREEN" AND/OR COLOR GREEN. TERMINAL MAY BE ADDITIONALLY IDENTIFIED BY EARTH SYMBOL .
- 5. N DENOTES GROUNDED LINE CONDUCTOR CONTACT. TERMINAL SHALL BE IDENTIFIED BY THE WORD "WHITE" AND/OR COLOR WHITE. TERMINAL MAY BE ADDITIONALLY IDENTIFIED BY THE LETTER "N".
- 6.  FOR SPLASHPROOF DEVICES.
- 7.  FOR WATERTIGHT DEVICES.
- 8.  FOR DEVICES WITH METAL ENCLOSURES.
- 9.  FOR DEVICES WITH ENCLOSURES OF INSULATING MATERIALS.

RATING CONFIGURATIONS  
FRONT VIEW - PLUG OR INLET

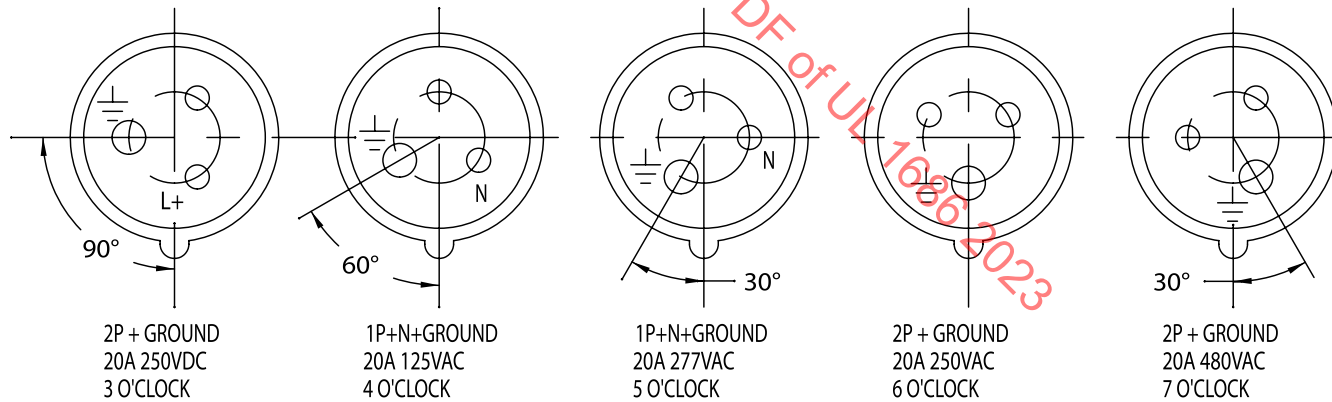
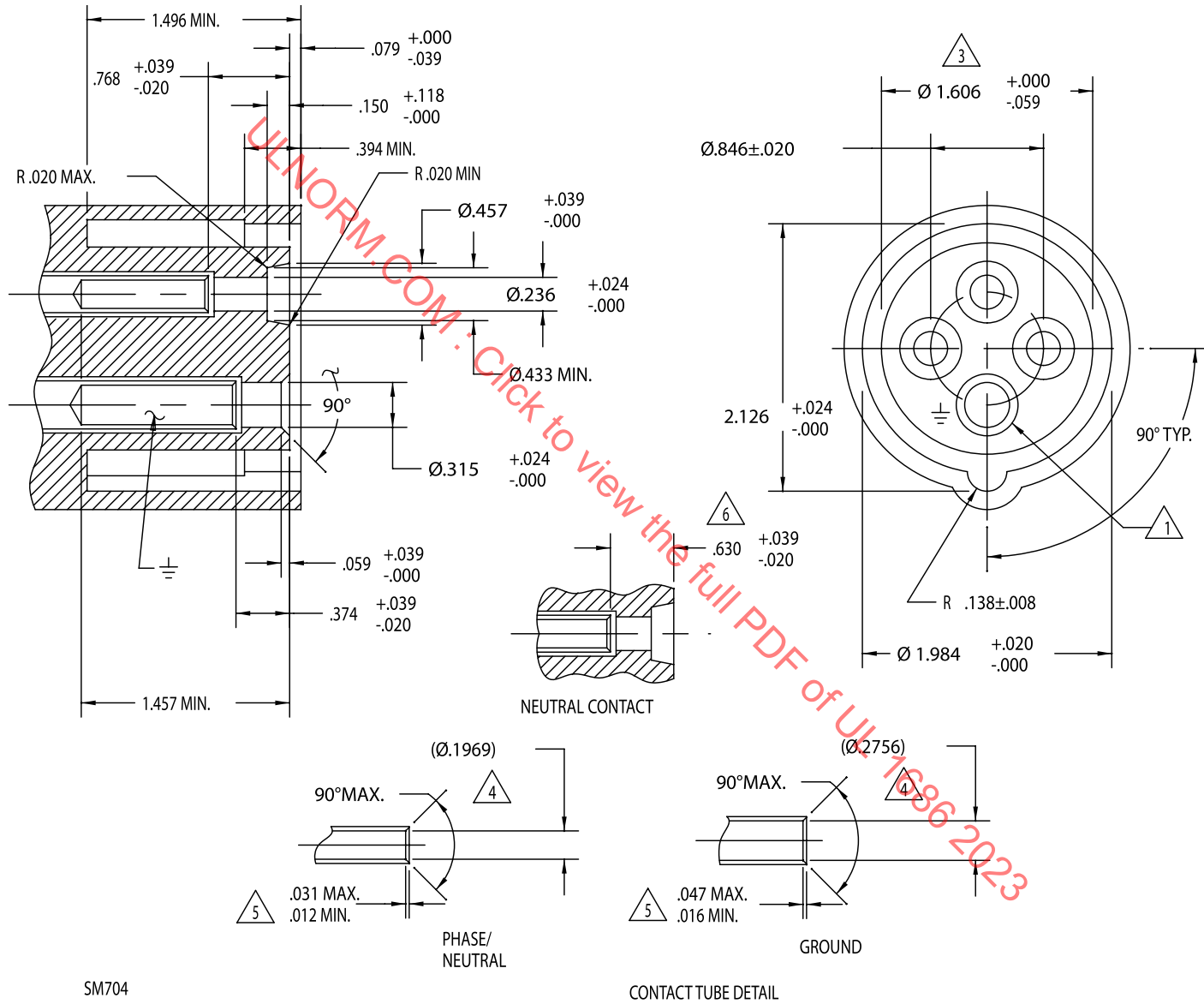

Figure C2.2 (cont.)

(Continued)



SM704

CONTACT TUBE DETAIL

20 Ampere, 4 Wire Without Pilot  
Receptacle or Connector

Figure C2.3

Figure C2.3 (Cont'd)

- 1. MAIN VIEW SHOWN WITH GROUND AT 6 O'CLOCK POSITION FOR REFERENCE ONLY. SEE RATING CONFIGURATION FOR RELEVANT POSITIONS.
- 2. HOLES OR RECESSES IN THE FRONTAL FACE, IF ANY, OTHER THAN THOSE FOR CONTACT TUBES, SHALL HAVE A DEPTH OF NOT MORE THAN .394 INCHES. (EXCEPTION: SEE NOTE 3)
- 3. THIS DIMENSION SHALL NOT EXCEED THE PRESCRIBED LIMIT AT ANY POINT OVER THE WHOLE DEPTH, AND SHALL BE WITHIN THE PRESCRIBED LIMITS OVER A MINIMUM DEPTH OF .236 INCHES WITH THE EXCEPTION OF A MAXIMUM OF 4 CUT-OUTS SPACED AROUND THE CIRCUMFERENCE WITH NOT MORE THAN ONE CUT-OUT BETWEEN ADJACENT HOLES FOR THE CONTACT TUBES AND EACH HAVING A WIDTH NOT EXCEEDING .590 INCHES INCLUDING ANY RADII. HOLES DEEPER THAN .394 INCHES IN THE AREA ARE ALLOWED.
- 4. DIMENSIONS REFER TO PIN DIAMETERS; THE CONTACTS TUBES NEED NOT BE CIRCULAR.
- 5. THE BEVELLING OF THE CONTACTS TUBES MAY BE ROUNDED OFF TOWARDS THE INTERNAL CYLINDRICAL SURFACE WITHIN A DISTANCE OF 1-1/2 TIMES THE MAXIMUM DIMENSION.
- 6. NEUTRAL CONTACT WHEN REQUIRED.
- 7.  $\perp$  DENOTES EQUIPMENT GROUND CONTACT. TERMINAL SHALL BE IDENTIFIED BY THE WORD "GREEN" AND/OR COLOR GREEN. TERMINAL MAY BE ADDITIONALLY IDENTIFIED BY EARTH SYMBOL ( $\perp$ ).
- 8. N DENOTES GROUNDED LINE CONDUCTOR CONTACT. TERMINAL SHALL BE IDENTIFIED BY THE WORD "WHITE" AND/OR COLOR WHITE. TERMINAL MAY BE ADDITIONALLY IDENTIFIED BY THE LETTER "N".

RATING CONFIGURATIONS  
FRONT VIEW - RECEPTACLE OR CONNECTOR

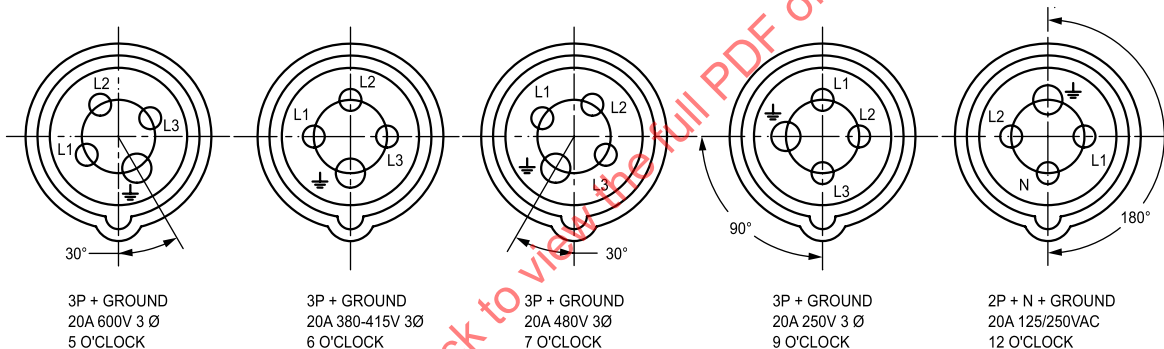

su1352

ULNORM.COM : Click to view the full PDF of UL 1686:23



Figure C2.4 (Cont.)

- 1. MAIN VIEW SHOWN WITH GROUND AT 6 O'CLOCK POSITION FOR REFERENCE ONLY. SEE RATING CONFIGURATION FOR RELEVANT POSITIONS.
- 2. COLLARS REQUIRED FOR DEVICES HAVING RATED OPERATING VOLTAGES EXCEEDING 500 V, OPTIONAL FOR OTHER DEVICES.
- 3. ENDS OF PINS MAY BE ROUNDED OFF TOWARDS THE EXTERNAL CYLINDRICAL SURFACE WITHIN A DISTANCE OF 1-1/2 TIMES OF THE MAXIMUM DIMENSION.
- 4.  $\perp$  DENOTES EQUIPMENT GROUND CONTACT. TERMINAL SHALL BE IDENTIFIED BY THE WORD "GREEN" AND/OR COLOR GREEN. TERMINAL MAY BE ADDITIONALLY IDENTIFIED BY EARTH SYMBOL ( $\perp$ ).
- 5. N DENOTES GROUNDED LINE CONDUCTOR CONTACT. TERMINAL SHALL BE IDENTIFIED BY THE WORD "WHITE" AND/OR COLOR WHITE. TERMINAL MAY BE ADDITIONALLY IDENTIFIED BY THE LETTER "N".
- 6.  $\triangle$  FOR SPLASH PROOF DEVICES.
- 7.  $\nabla$  FOR WATERTIGHT DEVICES.
- 8.  $\square$  FOR DEVICES WITH METAL ENCLOSURES.
- 9.  $\square$  FOR DEVICES WITH ENCLOSURES OF INSULATING MATERIALS.

RATING CONFIGURATIONS  
FRONT VIEW - PLUG OR INLET

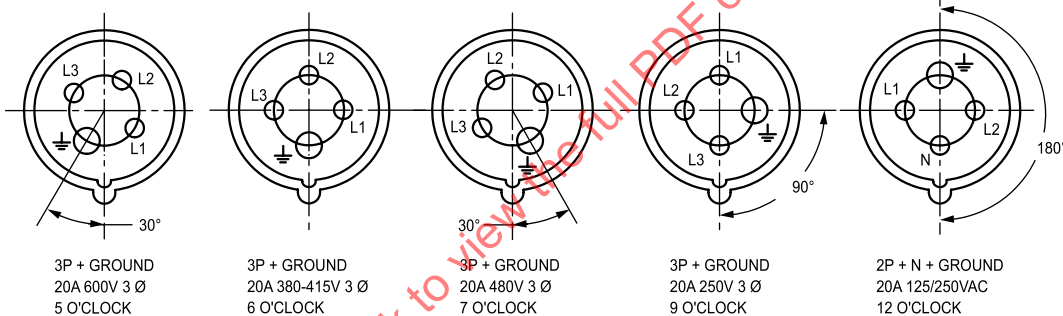

su1353

ULNORM.COM : Click to view the full PDF of UL 1686 2023

(Continued)

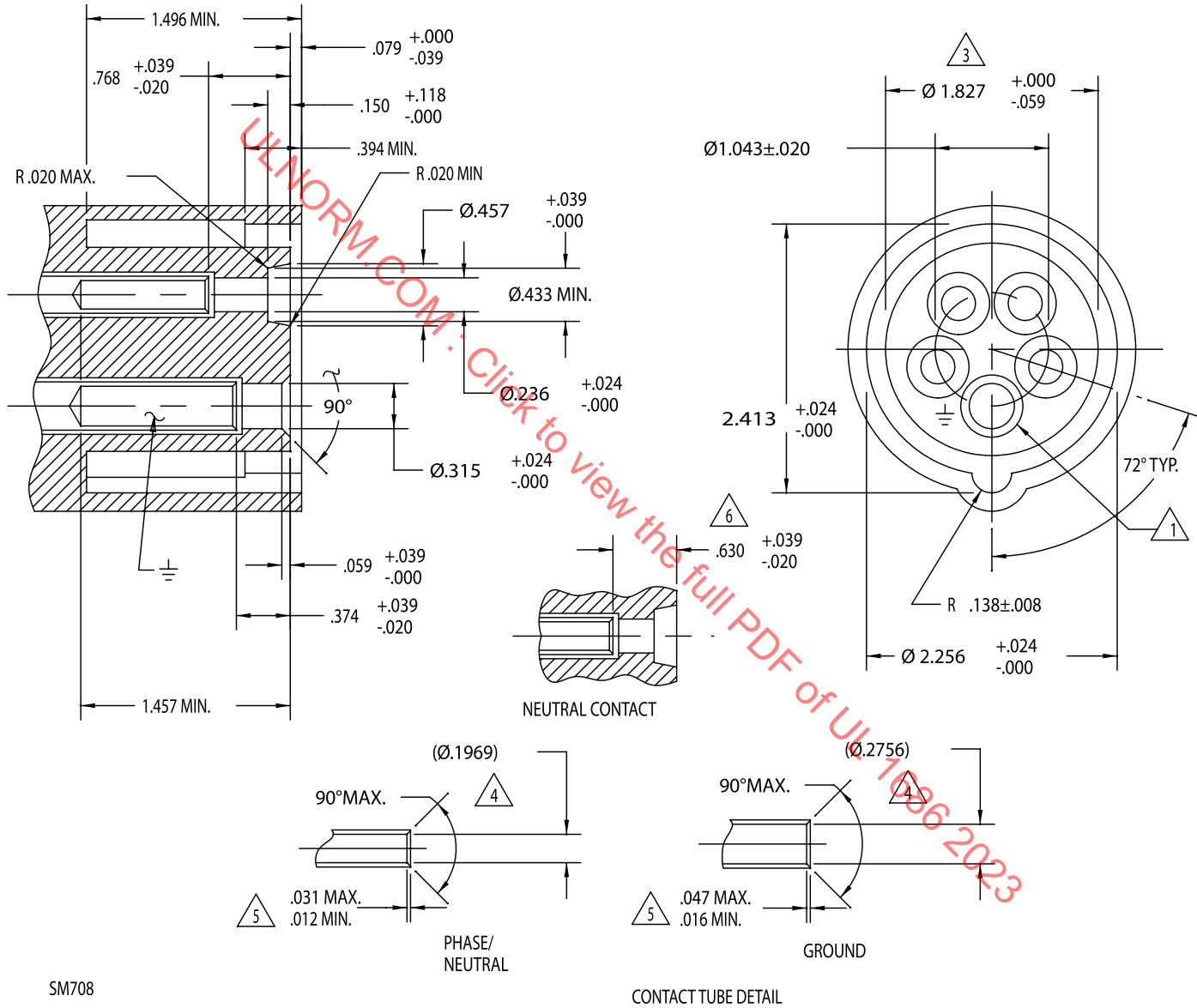

SM708

Figure C2.5  
Receptacle or Connector  
20 Ampere, 5 Wire Without Pilot

Figure C2.5 (Cont.)

- 1. MAIN VIEW SHOWN WITH GROUND AT 6 O'CLOCK POSITION FOR REFERENCE ONLY. SEE RATING CONFIGURATION FOR RELEVANT POSITIONS.
- 2. HOLES OR RECESSES IN THE FRONTAL FACE, IF ANY, OTHER THAN THOSE FOR CONTACT TUBES, SHALL HAVE A DEPTH OF NOT MORE THAN .394 INCHES. (EXCEPTION: SEE NOTE 3)
- 3. THIS DIMENSION SHALL NOT EXCEED THE PRESCRIBED LIMIT AT ANY POINT OVER THE WHOLE DEPTH, AND SHALL BE WITHIN THE PRESCRIBED LIMITS OVER A MINIMUM DEPTH OF .236 INCHES WITH THE EXCEPTION OF A MAXIMUM OF 5 CUT-OUTS SPACED AROUND THE CIRCUMFERENCE WITH NOT MORE THAN ONE CUT-OUT BETWEEN ADJACENT HOLES FOR THE CONTACT TUBES AND EACH HAVING A WIDTH NOT EXCEEDING .590 INCHES INCLUDING ANY RADII. HOLES DEEPER THAN .394 INCHES IN THE AREA ARE ALLOWED.
- 4. DIMENSIONS REFER TO PIN DIAMETERS; THE CONTACTS TUBES NEED NOT BE CIRCULAR.
- 5. THE BEVELLING OF THE CONTACTS TUBES MAY BE ROUNDED OFF TOWARDS THE INTERNAL CYLINDRICAL SURFACE WITHIN A DISTANCE OF 1-1/2 TIMES THE MAXIMUM DIMENSION.
- 6. NEUTRAL CONTACT WHEN REQUIRED.
- 7.  $\perp$  DENOTES EQUIPMENT GROUND CONTACT. TERMINAL SHALL BE IDENTIFIED BY THE WORD "GREEN" AND/OR COLOR GREEN. TERMINAL MAY BE ADDITIONALLY IDENTIFIED BY EARTH SYMBOL ( $\perp$ ).
- 8. N DENOTES GROUNDED LINE CONDUCTOR CONTACT. TERMINAL SHALL BE IDENTIFIED BY THE WORD "WHITE" AND/OR COLOR WHITE. TERMINAL MAY BE ADDITIONALLY IDENTIFIED BY THE LETTER "N".

RATING CONFIGURATIONS  
FRONT VIEW - RECEPTACLE OR CONNECTOR

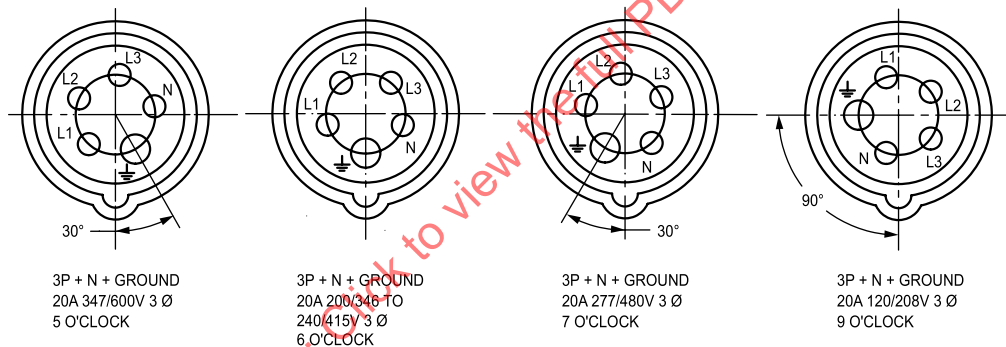

su1354

(Continued)

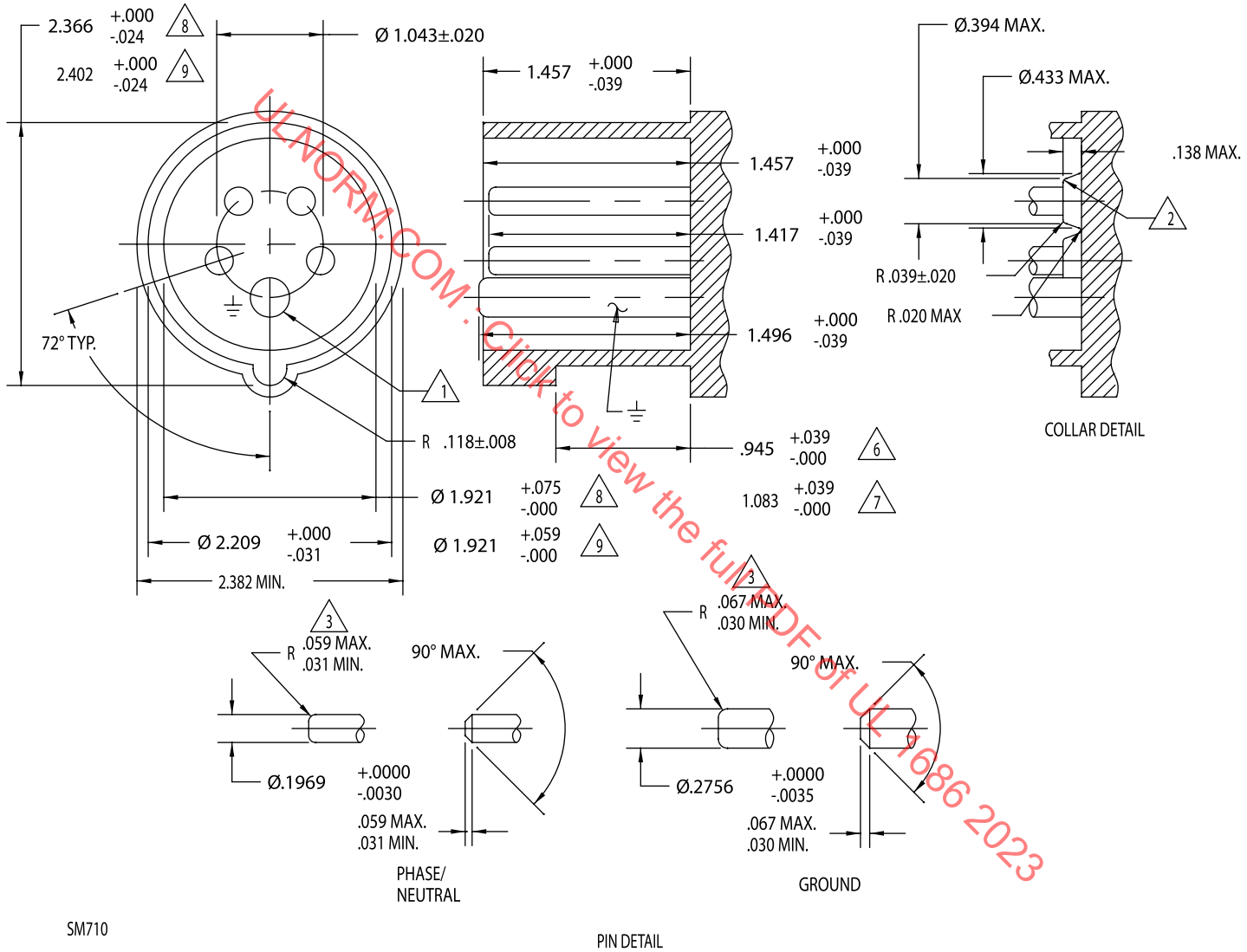

SM710

PIN DETAIL

Figure C2.6  
Plug or Inlet  
20 Ampere, 5 Wire Without Pilot

Figure C2.6 (Cont.)

- 1. MAIN VIEW SHOWN WITH GROUND AT 6 O'CLOCK POSITION FOR REFERENCE ONLY. SEE RATING CONFIGURATION FOR RELEVANT POSITIONS.
- 2. COLLARS REQUIRED FOR DEVICES HAVING RATED OPERATING VOLTAGES EXCEEDING 500 V, OPTIONAL FOR OTHER DEVICES.
- 3. ENDS OF PINS MAY BE ROUNDED OFF TOWARDS THE EXTERNAL CYLINDRICAL SURFACE WITHIN A DISTANCE OF 1-1/2 TIMES OF THE MAXIMUM DIMENSION.
- 4.  $\perp$  DENOTES EQUIPMENT GROUND CONTACT. TERMINAL SHALL BE IDENTIFIED BY THE WORD "GREEN" AND/OR COLOR GREEN. TERMINAL MAY BE ADDITIONALLY IDENTIFIED BY EARTH SYMBOL ( $\perp$ ).
- 5. N DENOTES GROUNDED LINE CONDUCTOR CONTACT. TERMINAL SHALL BE IDENTIFIED BY THE WORD "WHITE" AND/OR COLOR WHITE. TERMINAL MAY BE ADDITIONALLY IDENTIFIED BY THE LETTER "N".
- 6.  $\triangle$  FOR SPLASHPROOF DEVICES.
- 7.  $\nabla$  FOR WATERTIGHT DEVICES.
- 8.  $\square$  FOR DEVICES WITH METAL ENCLOSURES.
- 9.  $\triangle$  FOR DEVICES WITH ENCLOSURES OF INSULATING MATERIALS.

RATING CONFIGURATIONS  
FRONT VIEW - PLUG OR INLET

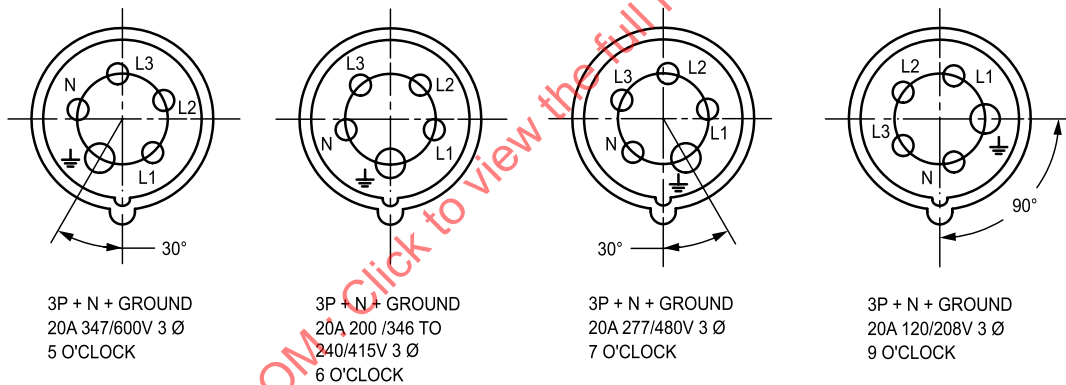

su1355

ULNORM.COM Click to view the full PDF of UL 1686 2023

(Continued)

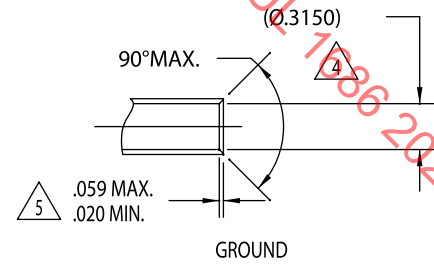
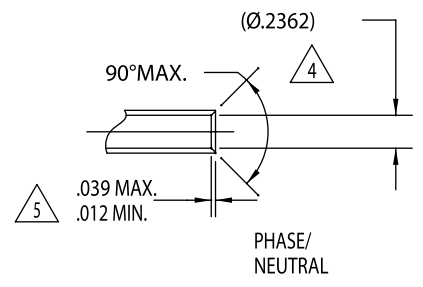
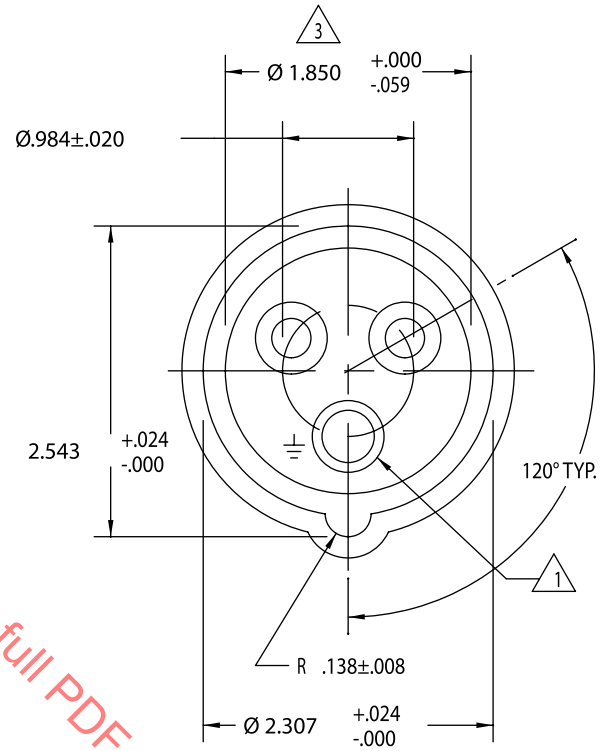
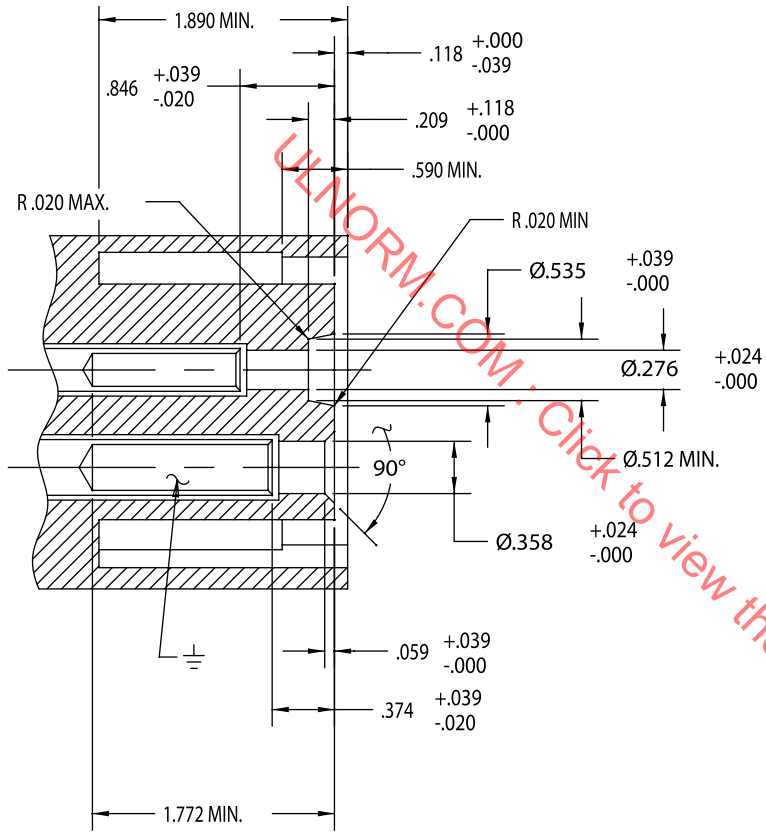

SM712A

CONTACT TUBE DETAIL

Receptacle or Connector  
30 Ampere, 3 Wire Without Pilot

Figure C2.7

Figure C2.7 (Cont.)

- 1. MAIN VIEW SHOWN WITH GROUND AT 6 O' CLOCK POSITION FOR REFERENCE ONLY. SEE RATING CONFIGURATION FOR RELEVANT POSITIONS.
- 2. HOLES OR RECESSES IN THE FRONTAL FACE, IF ANY, OTHER THAN THOSE FOR CONTACT TUBES, SHALL HAVE A DEPTH OF NOT MORE THAN .394 INCHES (EXCEPTION: SEE NOTE 3)
- 3. THIS DIMENSION SHALL NOT EXCEED THE PRESCRIBED LIMIT AT ANY POINT OVER THE WHOLE DEPTH, AND SHALL BE WITHIN THE PRESCRIBED LIMITS OVER A MINIMUM DEPTH OF .236 INCHES WITH THE EXCEPTION OF A MAXIMUM OF 3 CUT-OUTS SPACED AROUND THE CIRCUMFERENCE WITH NOT MORE THAN ONE CUT-OUT BETWEEN ADJACENT HOLES FOR THE CONTACT TUBES AND EACH HAVING A WIDTH NOT EXCEEDING .590 INCHES INCLUDING ANY RADII. HOLES DEEPER THAN .394 INCHES IN THE AREA ARE ALLOWED.
- 4. DIMENSIONS REFER TO PIN DIAMETERS; THE CONTACTS TUBES NEED NOT BE CIRCULAR.
- 5. THE BEVELLING OF CONTACT TUBES MAY BE ROUNDED OFF TOWARDS THE INTERNAL CYLINDRICAL SURFACE WITHIN A DISTANCE OF 1-1/2 TIMES THE MAXIMUM DIMENSION.
- 6.  $\equiv$  DENOTES EQUIPMENT GROUND CONTACT. TERMINAL SHALL BE IDENTIFIED BY THE WORD "GREEN" AND/OR COLOR GREEN. TERMINAL MAY BE ADDITIONALLY IDENTIFIED BY EARTH SYMBOL ( $\equiv$ ).
- 7. N DENOTES GROUNDED LINE CONDUCTOR CONTACT. TERMINAL SHALL BE IDENTIFIED BY THE WORD "WHITE" AND/OR COLOR WHITE. TERMINAL MAY BE ADDITIONALLY IDENTIFIED BY THE LETTER "N".

RATING CONFIGURATIONS  
FRONT VIEW - RECEPTACLE OR CONNECTOR

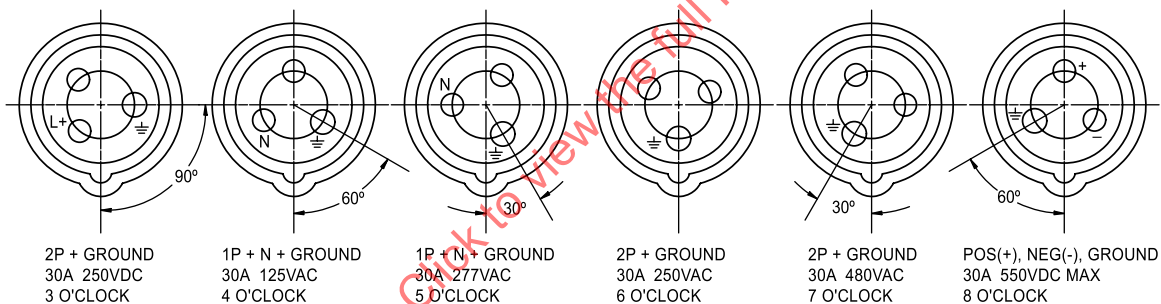

su0698

FIGURE C2.7 (CONT.)

ULNORM.COM : Click to view the full PDF of UL 1686 2023

(Continued)

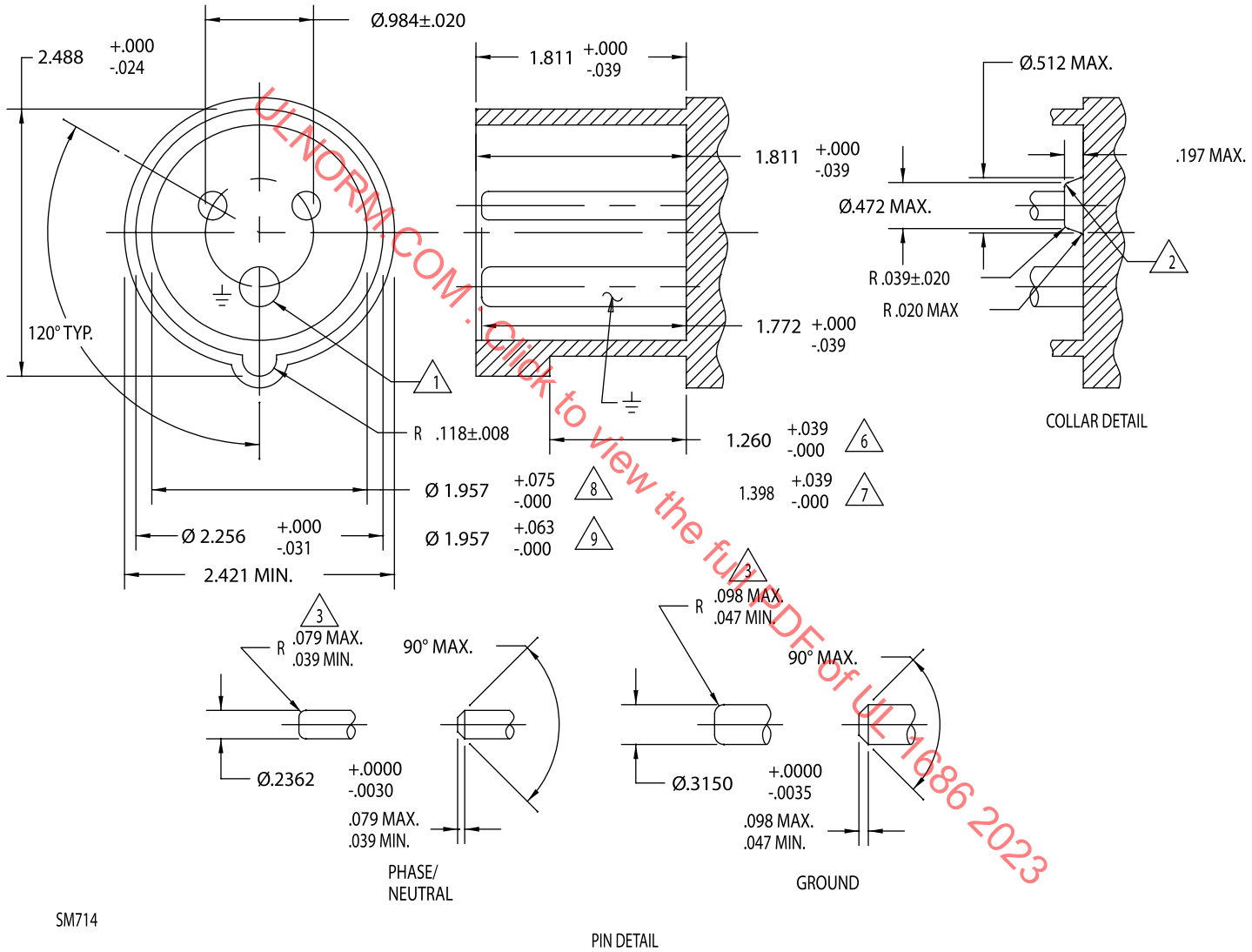

SM714

PIN DETAIL

Figure C2.8  
Plug or Receptacle  
30 Ampere, 3 Wire Without Pilot

Figure C2.8 (Cont.)

- 1. MAIN VIEW SHOWN WITH GROUND AT 6 O'CLOCK POSITION FOR REFERENCE ONLY. SEE RATING CONFIGURATION FOR RELEVANT POSITIONS.
- 2. COLLARS REQUIRED FOR DEVICES HAVING RATED OPERATING VOLTAGES EXCEEDING 500 V. OPTIONAL FOR OTHER DEVICES.
- 3. END OF PINS MAY BE ROUNDED OFF TOWARDS THE EXTERNAL CYLINDRICAL SURFACE WITHIN A DISTANCE OF 1-1/2 TIMES OF THE MAXIMUM DIMENSIONS.
- 4.  $\perp$  DENOTES EQUIPMENT GROUND CONTACT. TERMINAL SHALL BE IDENTIFIED BY THE WORD "GREEN" AND/OR COLOR GREEN. TERMINAL MAY BE ADDITIONALLY IDENTIFIED BY EARTH SYMBOL ( $\perp$ ).
- 5. N DENOTES GROUNDED LINE CONDUCTOR CONTACT. TERMINAL SHALL BE IDENTIFIED BY THE WORD "WHITE" AND/OR COLOR WHITE. TERMINAL MAY BE ADDITIONALLY IDENTIFIED BY THE LETTER "N".
- 6.  $\triangle$  FOR SPLASHPROOF DEVICES.
- 7.  $\nabla$  FOR WATERTIGHT DEVICES.
- 8.  $\triangle$  FOR DEVICES WITH METAL ENCLOSURES.
- 9.  $\triangle$  FOR DEVICES WITH ENCLOSURES OF INSULATING MATERIALS.

RATING CONFIGURATIONS  
FRONT VIEW - PLUG OR INLET

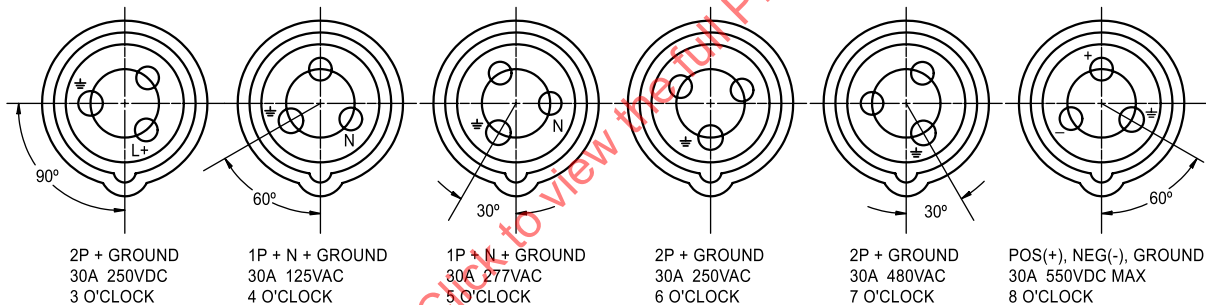

su0699

FIGURE C2.8 (CONT.)

ULNORM.COM : Click to view the PDF of UL 1686 2023

(Continued)

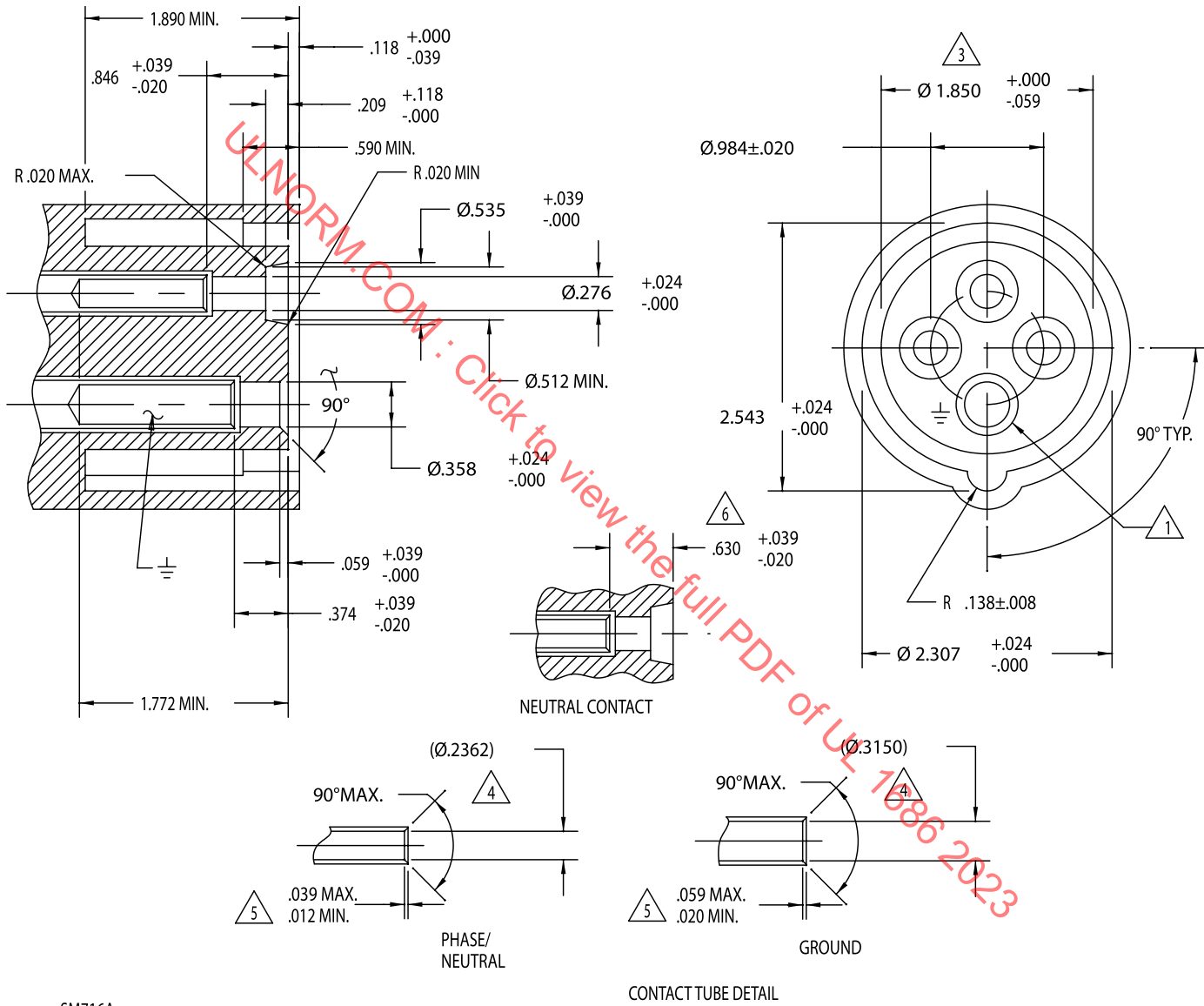

SM716A

30 Ampere, 4 Wire Without Pilot  
Receptacle or Connector

Figure C2.9

Figure C2.9 (Cont.)

- 1. MAIN VIEW SHOWN WITH GROUND AT 6 O'CLOCK POSITION FOR REFERENCE ONLY. SEE RATING CONFIGURATION FOR RELEVANT POSITIONS.
- 2. HOLES OR RECESSES IN THE FRONTAL FACE, IF ANY, OTHER THAN THOSE FOR CONTACT TUBES, SHALL HAVE A DEPTH OF NOT MORE THAN .394 INCHES. (EXCEPTION: SEE NOTE 3)
- 3. THIS DIMENSION SHALL NOT EXCEED THE PRESCRIBED LIMIT AT ANY POINT OVER THE WHOLE DEPTH, AND SHALL BE WITHIN THE PRESCRIBED LIMITS OVER A MINIMUM DEPTH OF .236 INCHES WITH THE EXCEPTION OF A MAXIMUM OF 4 CUT-OUTS SPACED AROUND THE CIRCUMFERENCE WITH NOT MORE THAN ONE CUT-OUT BETWEEN ADJACENT HOLES FOR THE CONTACT TUBES AND EACH HAVING A WIDTH NOT EXCEEDING .590 INCHES INCLUDING ANY RADII. HOLES DEEPER THAN .394 INCHES IN THE AREA ARE ALLOWED.
- 4. DIMENSIONS REFER TO PIN DIAMETERS; THE CONTACTS TUBES NEED NOT BE CIRCULAR.
- 5. THE BEVELLING OF THE CONTACTS TUBES MAY BE ROUNDED OFF TOWARDS THE INTERNAL CYLINDRICAL SURFACE WITHIN A DISTANCE OF 1-1/2 TIMES THE MAXIMUM DIMENSION.
- 6. NEUTRAL CONTACT WHEN REQUIRED.
- 7.  $\perp$  DENOTES EQUIPMENT GROUND CONTACT. TERMINAL SHALL BE IDENTIFIED BY THE WORD "GREEN" AND/OR COLOR GREEN. TERMINAL MAY BE ADDITIONALLY IDENTIFIED BY EARTH SYMBOL ( $\perp$ ).
- 8. N DENOTES GROUNDED LINE CONDUCTOR CONTACT. TERMINAL SHALL BE IDENTIFIED BY THE WORD "WHITE" AND/OR COLOR WHITE. TERMINAL MAY BE ADDITIONALLY IDENTIFIED BY THE LETTER "N".

RATING CONFIGURATIONS  
FRONT VIEW - RECEPTACLE OR CONNECTOR

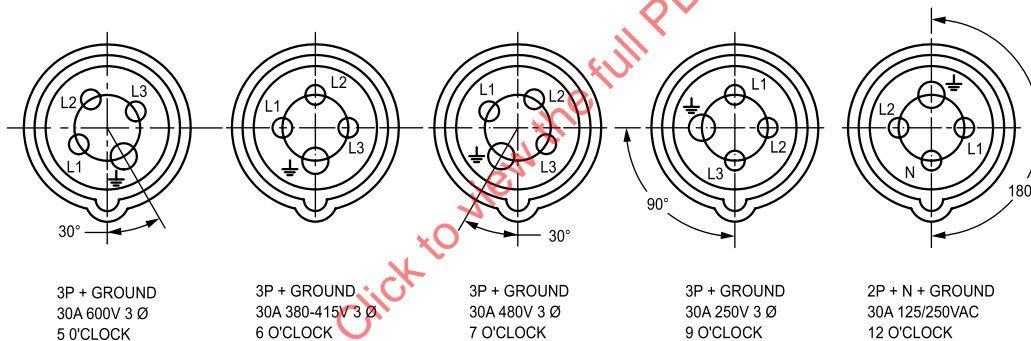

su1356

ULNORM.COM : Click to view the full PDF of UL 1686:2023

(Continued)

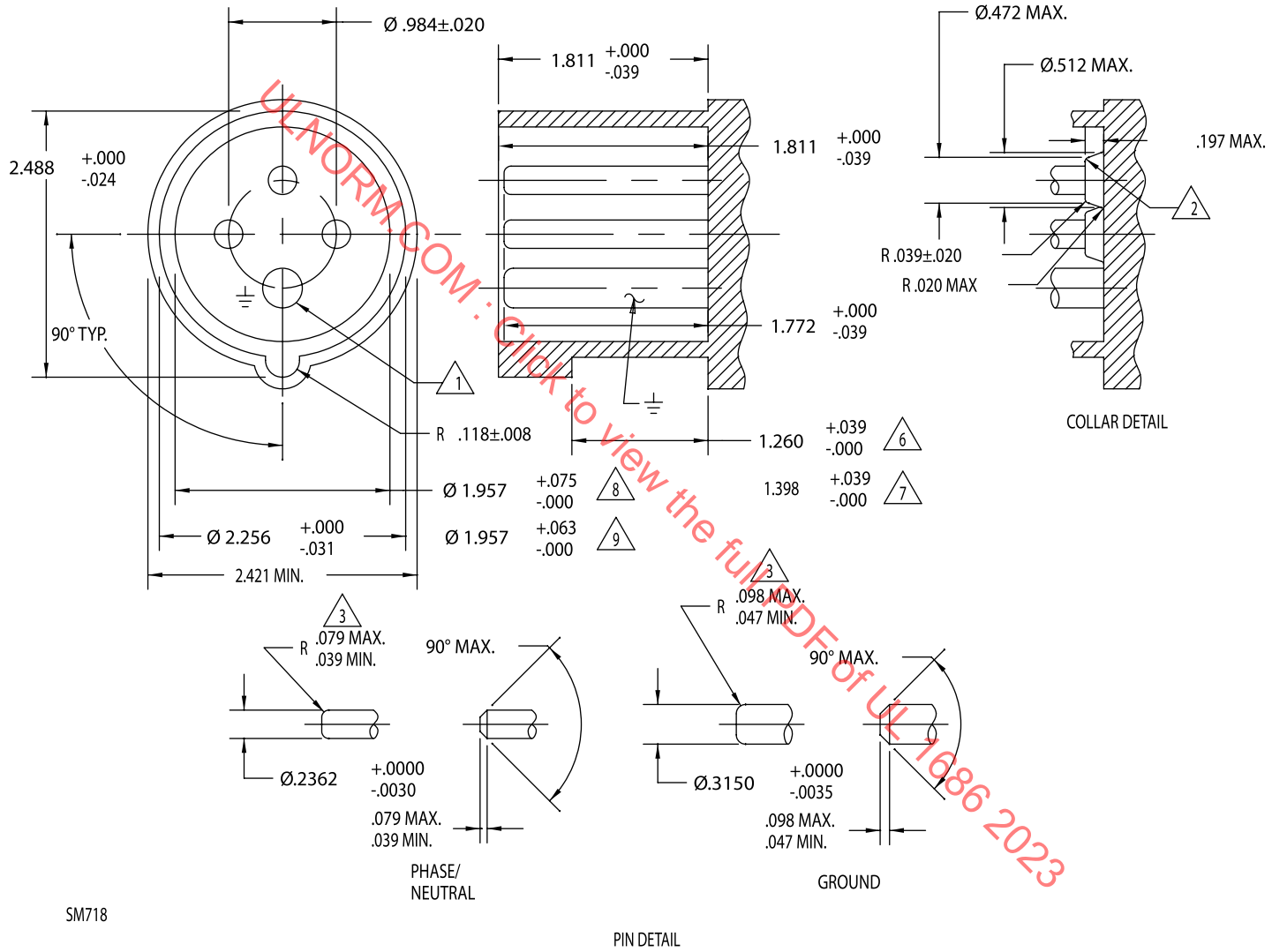

SM718

PIN DETAIL

Figure C2.10  
Plug or Inlet  
30 Ampere, 4 Wire Without Pilot

- 1. MAIN VIEW SHOWN WITH GROUND AT 6 O'CLOCK POSITION FOR REFERENCE ONLY. SEE RATING CONFIGURATION FOR RELEVANT POSITIONS.
- 2. COLLARS REQUIRED FOR DEVICES HAVING RATED OPERATING VOLTAGES EXCEEDING 500 V, OPTIONAL FOR OTHER DEVICES.
- 3. ENDS OF PINS MAY BE ROUNDED OFF TOWARDS THE EXTERNAL CYLINDRICAL SURFACE WITHIN A DISTANCE OF 1-1/2 TIMES OF THE MAXIMUM DIMENSION.
- 4.  $\perp$  DENOTES EQUIPMENT GROUND CONTACT. TERMINAL SHALL BE IDENTIFIED BY THE WORD "GREEN" AND/OR COLOR GREEN. TERMINAL MAY BE ADDITIONALLY IDENTIFIED BY EARTH SYMBOL ( $\perp$ ).
- 5. N DENOTES GROUNDED LINE CONDUCTOR CONTACT. TERMINAL SHALL BE IDENTIFIED BY THE WORD "WHITE" AND/OR COLOR WHITE. TERMINAL MAY BE ADDITIONALLY IDENTIFIED BY THE LETTER "N".
- 6. FOR SPLASH PROOF DEVICES.
- 7. FOR WATERTIGHT DEVICES.
- 8. FOR DEVICES WITH METAL ENCLOSURES.
- 9. FOR DEVICES WITH ENCLOSURES OF INSULATING MATERIALS.

RATING CONFIGURATIONS  
FRONT VIEW - PLUG OR INLET

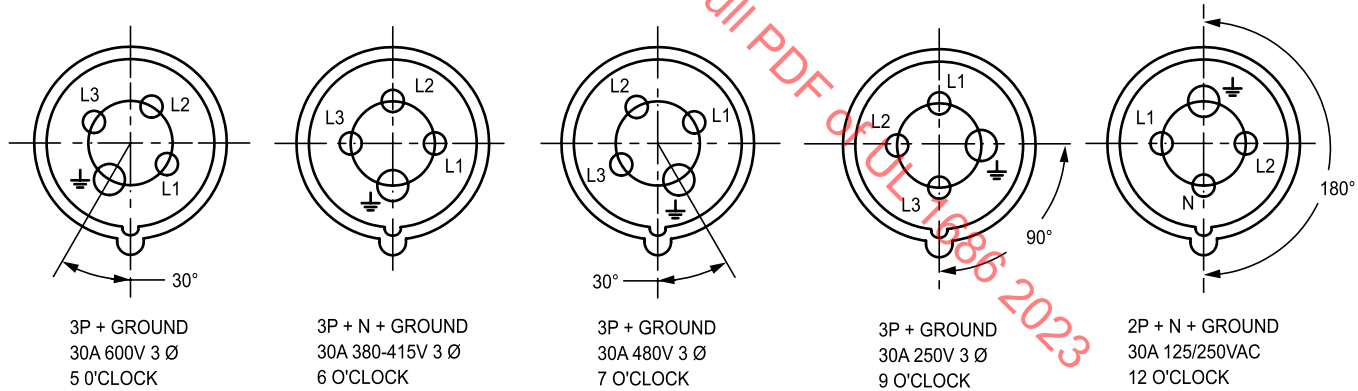

su1357

Figure C2.10 (Cont.)

32/30 Ampere, 4 Wire Without Pilot Only for Refrigerated Containers  
Receptacle or Connector

Figure C2.11

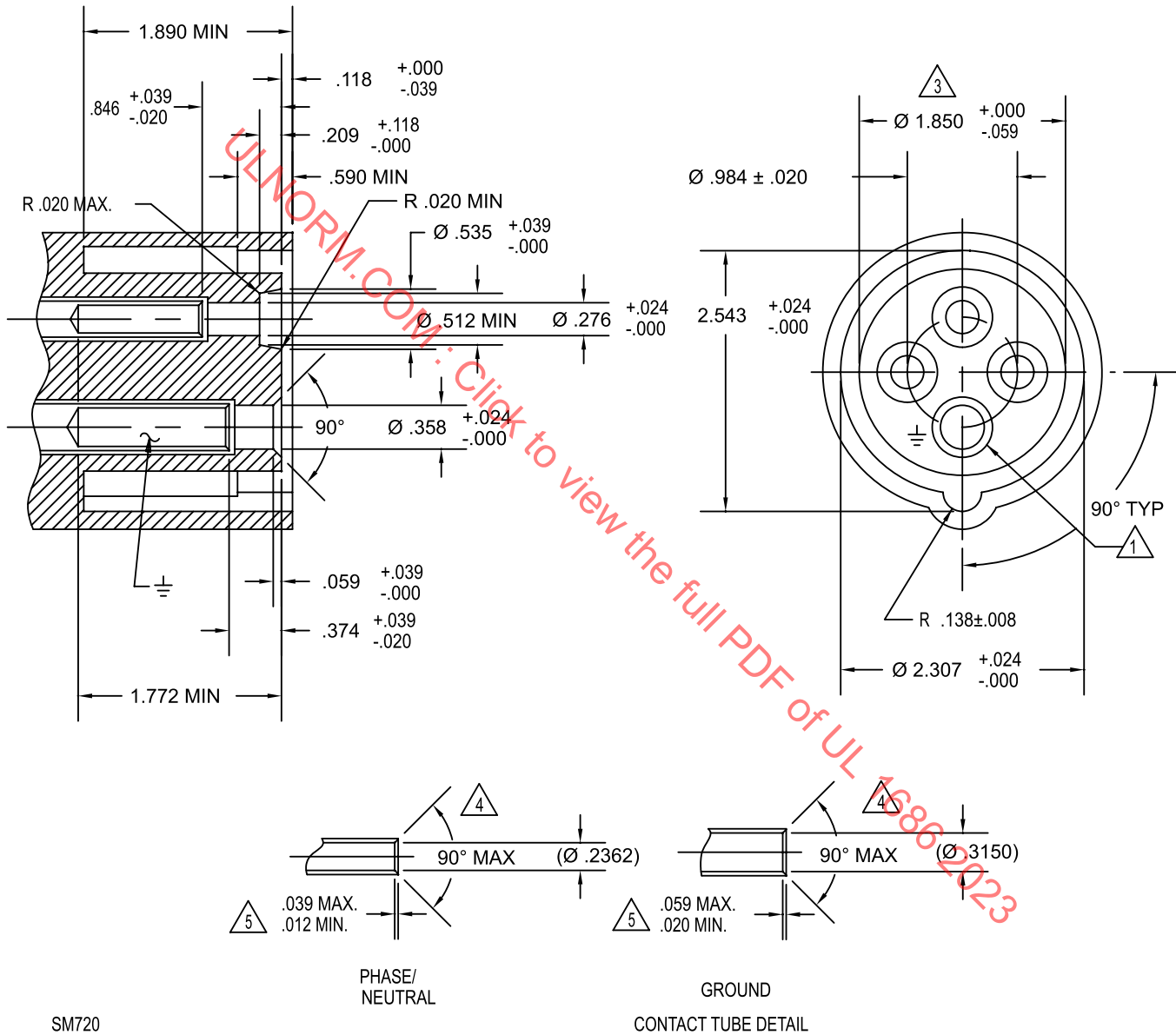

(Continued)

SM720

Figure C2.11 (Cont.)

- 1. MAIN VIEW SHOWN WITH GROUND AT 6 O'CLOCK POSITION FOR REFERENCE ONLY. SEE RATING CONFIGURATION FOR RELEVANT POSITIONS.
- 2. HOLES OR RECESSES IN THE FRONTAL FACE, IF ANY, OTHER THAN THOSE FOR CONTACT TUBES, SHALL HAVE A DEPTH OF NOT MORE THAN .394 INCHES. (EXCEPTION: SEE NOTE 3)
- 3. THIS DIMENSION SHALL NOT EXCEED THE PRESCRIBED LIMIT AT ANY POINT OVER THE WHOLE DEPTH, AND SHALL BE WITHIN THE PRESCRIBED LIMITS OVER A MINIMUM DEPTH OF .236 INCHES WITH THE EXCEPTION OF A MAXIMUM OF 4 CUT-OUTS SPACED AROUND THE CIRCUMFERENCE WITH NOT MORE THAN ONE CUT-OUT BETWEEN ADJACENT HOLES FOR THE CONTACT TUBES AND EACH HAVING A WIDTH NOT EXCEEDING .590 INCHES INCLUDING ANY RADII. HOLES DEEPER THAN .394 INCHES IN THE AREA ARE ALLOWED.
- 4. DIMENSIONS REFER TO PIN DIAMETERS; THE CONTACTS TUBES NEED NOT BE CIRCULAR.
- 5. THE BEVELLING OF THE CONTACTS TUBES MAY BE ROUNDED OFF TOWARDS THE INTERNAL CYLINDRICAL SURFACE WITHIN A DISTANCE OF 1-1/2 TIMES THE MAXIMUM DIMENSION.
- 6.  $\perp$  DENOTES EQUIPMENT GROUND CONTACT. TERMINAL SHALL BE IDENTIFIED BY THE WORD "GREEN" AND/OR COLOR GREEN. TERMINAL MAY BE ADDITIONALLY IDENTIFIED BY EARTH SYMBOL ( $\perp$ ).
- 7. N DENOTES GROUNDED LINE CONDUCTOR CONTACT. TERMINAL SHALL BE IDENTIFIED BY THE WORD "WHITE" AND/OR COLOR WHITE. TERMINAL MAY BE ADDITIONALLY IDENTIFIED BY THE LETTER "N".
- 8. THIS CONFIGURATION IS DUAL RATED FOR THE INTERNATIONAL TRANSSHIPMENT OF REFRIGERATED CONTAINERS. OVERCURRENT PROTECTION SHALL BE RATED AT STANDARD RATINGS PREVALENT LOCALLY.

RATING CONFIGURATIONS  
FRONT VIEW - RECEPTACLE OR CONNECTOR

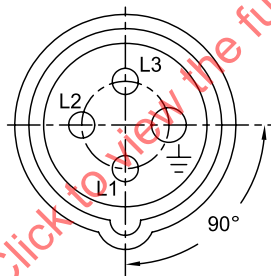

3P + GROUND  
30A 440V 60Hz  
32A 380V 60Hz  
ONLY FOR REFRIGERATED CONTAINERS  
3 O'CLOCK

SM721b

Figure C2.12  
Plug or Inlet

32/30 Ampere, 4 Wire Without Pilot Only for Refrigerated Containers

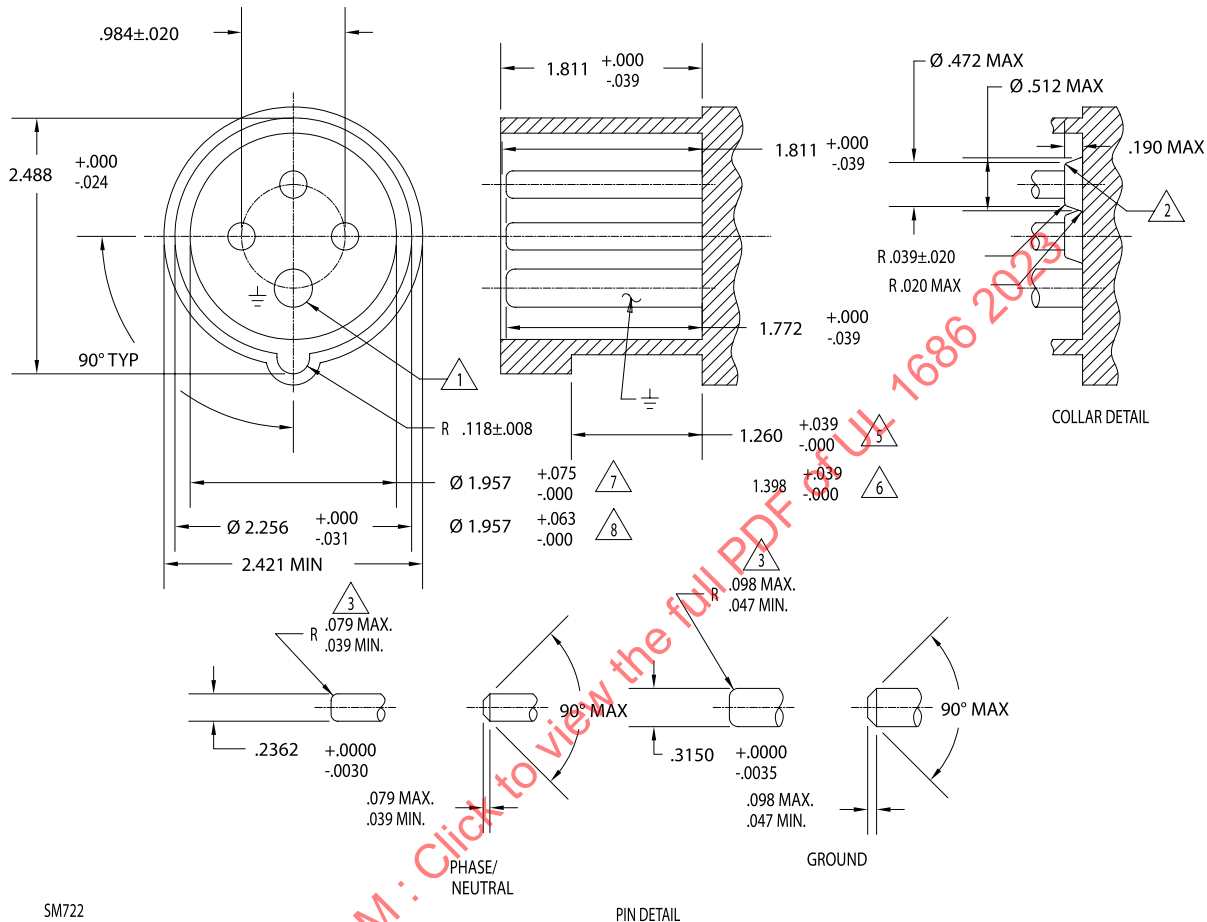



(Continued)

1 MAIN VIEW SHOWN WITH GROUND AT 6 O'CLOCK POSITION FOR REFERENCE ONLY. SEE RATING CONFIGURATION FOR RELEVANT POSITIONS.

2 COLLARS REQUIRED FOR DEVICES HAVING RATED OPERATING VOLTAGES EXCEEDING 500 V, OPTIONAL FOR OTHER DEVICES.

3 ENDS OF PINS MAY BE ROUNDED OFF TOWARDS THE EXTERNAL CYLINDRICAL SURFACE WITHIN A DISTANCE OF 1-1/2 TIMES OF THE MAXIMUM DIMENSION.

4.  DENOTES EQUIPMENT GROUND CONTACT. TERMINAL SHALL BE IDENTIFIED BY THE WORD "GREEN" AND/OR COLOR GREEN. TERMINAL MAY BE ADDITIONALLY IDENTIFIED BY EARTH SYMBOL (  ).

5 FOR SPLASHPROOF DEVICES.

6 FOR WATERTIGHT DEVICES.

7 FOR DEVICES WITH METAL ENCLOSURES.

8 FOR DEVICES WITH ENCLOSURES OF INSULATING MATERAILS.

9. THIS CONFIGURATION IS DUAL RATED FOR THE INTERNATIONAL TRANSSHIPMENT OF REFRIGERATED CONTAINERS. OVERCURRENT PROTECTION SHALL BE RATED AT STANDARD RATINGS PREVALENT LOCALLY.

RATING CONFIGURATIONS  
FRONT VIEW - PLUG OR INLET

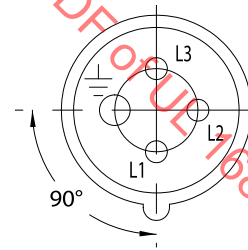

3P + GROUND  
30A 440V 60Hz  
32A 380V 50Hz  
ONLY FOR REFRIGERATED CONTAINERS  
3 O'CLOCK

ULNORM.COM to view the full PDF of UL 1686 2023

Figure C2.12 (Cont.)

(Continued)

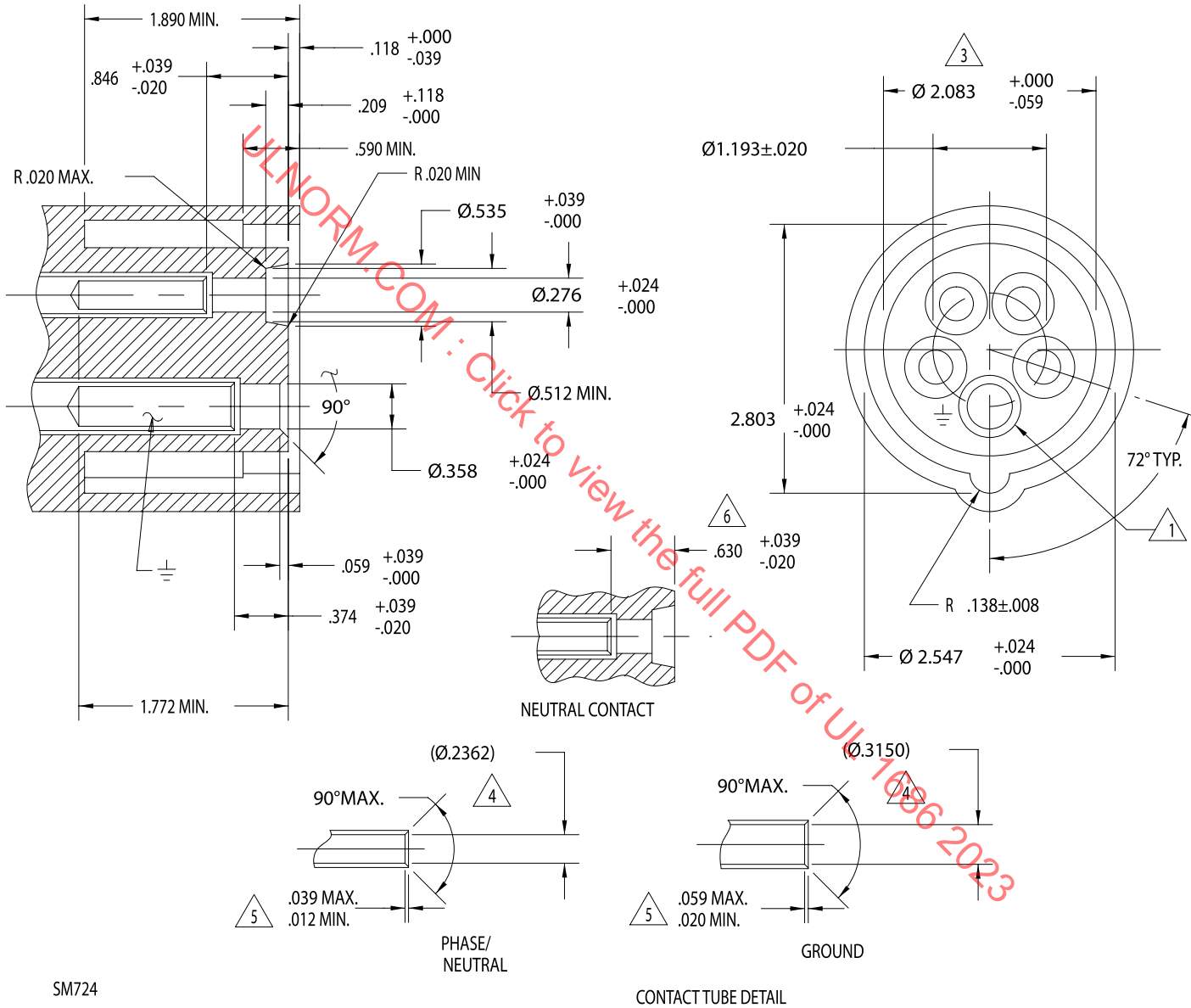

SM724

Figure C2.13  
Receptacle or Connector  
30 Ampere, 5 Wire Without Pilot

- 1. MAIN VIEW SHOWN WITH GROUND AT 6 O'CLOCK POSITION FOR REFERENCE ONLY. SEE RATING CONFIGURATION FOR RELEVANT POSITIONS.
- 2. HOLES OR RECESSES IN THE FRONTAL FACE, IF ANY, OTHER THAN THOSE FOR CONTACT TUBES, SHALL HAVE A DEPTH OF NOT MORE THAN .394 INCHES. (EXCEPTION: SEE NOTE 3)
- 3. THIS DIMENSION SHALL NOT EXCEED THE PRESCRIBED LIMIT AT ANY POINT OVER THE WHOLE DEPTH, AND SHALL BE WITHIN THE PRESCRIBED LIMITS OVER A MINIMUM DEPTH OF .236 INCHES WITH THE EXCEPTION OF A MAXIMUM OF 5 CUT-OUTS SPACED AROUND THE CIRCUMFERENCE WITH NOT MORE THAN ONE CUT-OUT BETWEEN ADJACENT HOLES FOR THE CONTACT TUBES AND EACH HAVING A WIDTH NOT EXCEEDING .590 INCHES INCLUDING ANY RADII. HOLES DEEPER THAN .394 INCHES IN THE AREA ARE ALLOWED.
- 4. DIMENSIONS REFER TO PIN DIAMETERS; THE CONTACTS TUBES NEED NOT BE CIRCULAR.
- 5. THE BEVELLING OF THE CONTACTS TUBES MAY BE ROUNDED OFF TOWARDS THE INTERNAL CYLINDRICAL SURFACE WITHIN A DISTANCE OF 1-1/2 TIMES THE MAXIMUM DIMENSION.
- 6. NEUTRAL CONTACT WHEN REQUIRED.
- 7.  $\perp$  DENOTES EQUIPMENT GROUND CONTACT. TERMINAL SHALL BE IDENTIFIED BY THE WORD "GREEN" AND/OR COLOR GREEN. TERMINAL MAY BE ADDITIONALLY IDENTIFIED BY EARTH SYMBOL ( $\perp$ ).
- 8. N DENOTES GROUNDED LINE CONDUCTOR CONTACT. TERMINAL SHALL BE IDENTIFIED BY THE WORD "WHITE" AND/OR COLOR WHITE. TERMINAL MAY BE ADDITIONALLY IDENTIFIED BY THE LETTER "N".

RATING CONFIGURATIONS  
FRONT VIEW - RECEPTACLE OR CONNECTOR

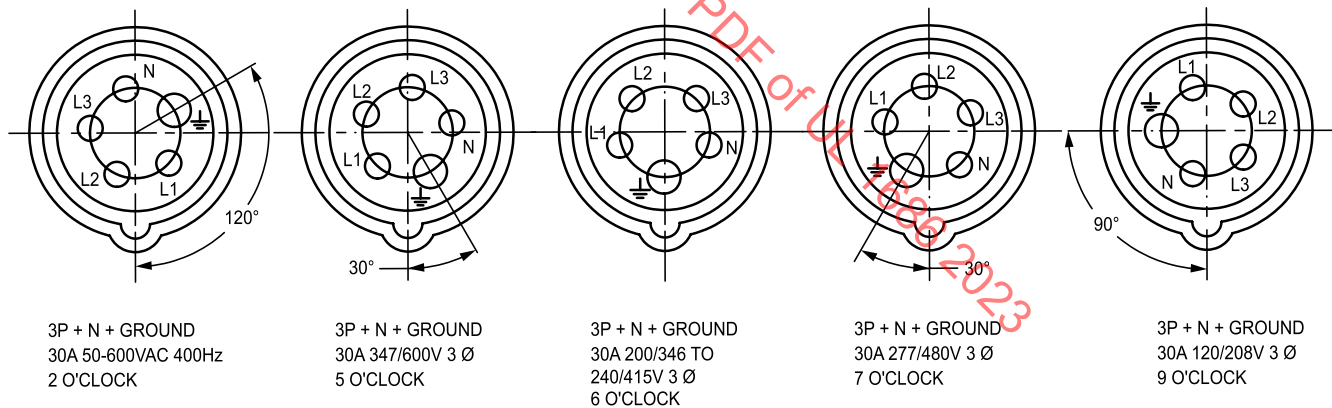

su1358

Figure C2.13 (Cont.)



- 1 MAIN VIEW SHOWN WITH GROUND AT 6 O'CLOCK POSITION FOR REFERENCE ONLY. SEE RATING CONFIGURATION FOR RELEVANT POSITIONS.
- 2 COLLARS REQUIRED FOR DEVICES HAVING RATED OPERATING VOLTAGES EXCEEDING 500 V, OPTIONAL FOR OTHER DEVICES.
- 3 ENDS OF PINS MAY BE ROUNDED OFF TOWARDS THE EXTERNAL CYLINDRICAL SURFACE WITHIN A DISTANCE OF 1-1/2 TIMES OF THE MAXIMUM DIMENSION.
- 4  $\perp$  DENOTES EQUIPMENT GROUND CONTACT. TERMINAL SHALL BE IDENTIFIED BY THE WORD "GREEN" AND/OR COLOR GREEN. TERMINAL MAY BE ADDITIONALLY IDENTIFIED BY EARTH SYMBOL ( $\perp$ ).
- 5. N DENOTES GROUNDED LINE CONDUCTOR CONTACT. TERMINAL SHALL BE IDENTIFIED BY THE WORD "WHITE" AND/OR COLOR WHITE. TERMINAL MAY BE ADDITIONALLY IDENTIFIED BY THE LETTER "N".
- 6 FOR SPLASH PROOF DEVICES.
- 7 FOR WATERTIGHT DEVICES.
- 8 FOR DEVICES WITH METAL ENCLOSURES.
- 9 FOR DEVICES WITH ENCLOSURES OF INSULATING MATERIALS.

RATING CONFIGURATIONS  
FRONT VIEW - PLUG OR INLET

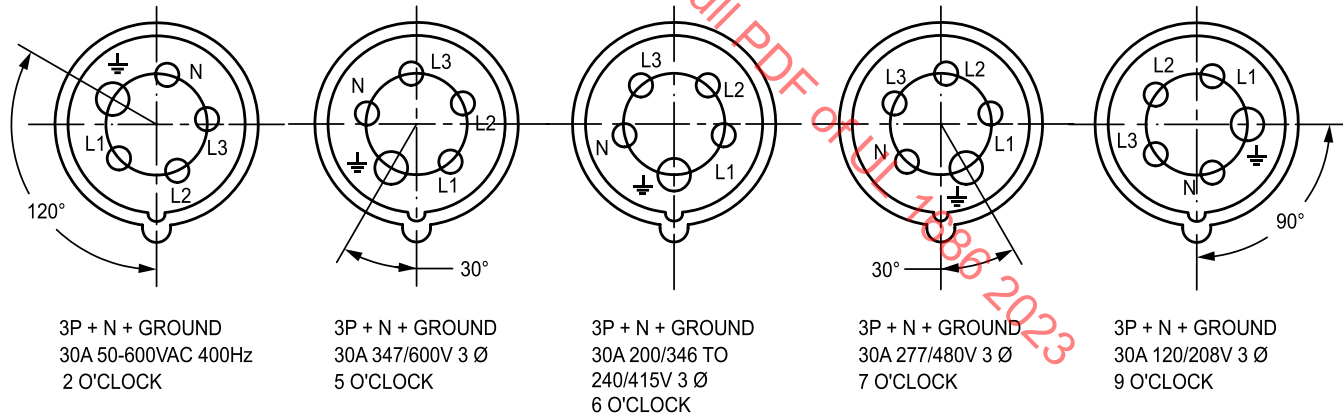

su1359

Figure C2.14 (Cont.)

(Continued)

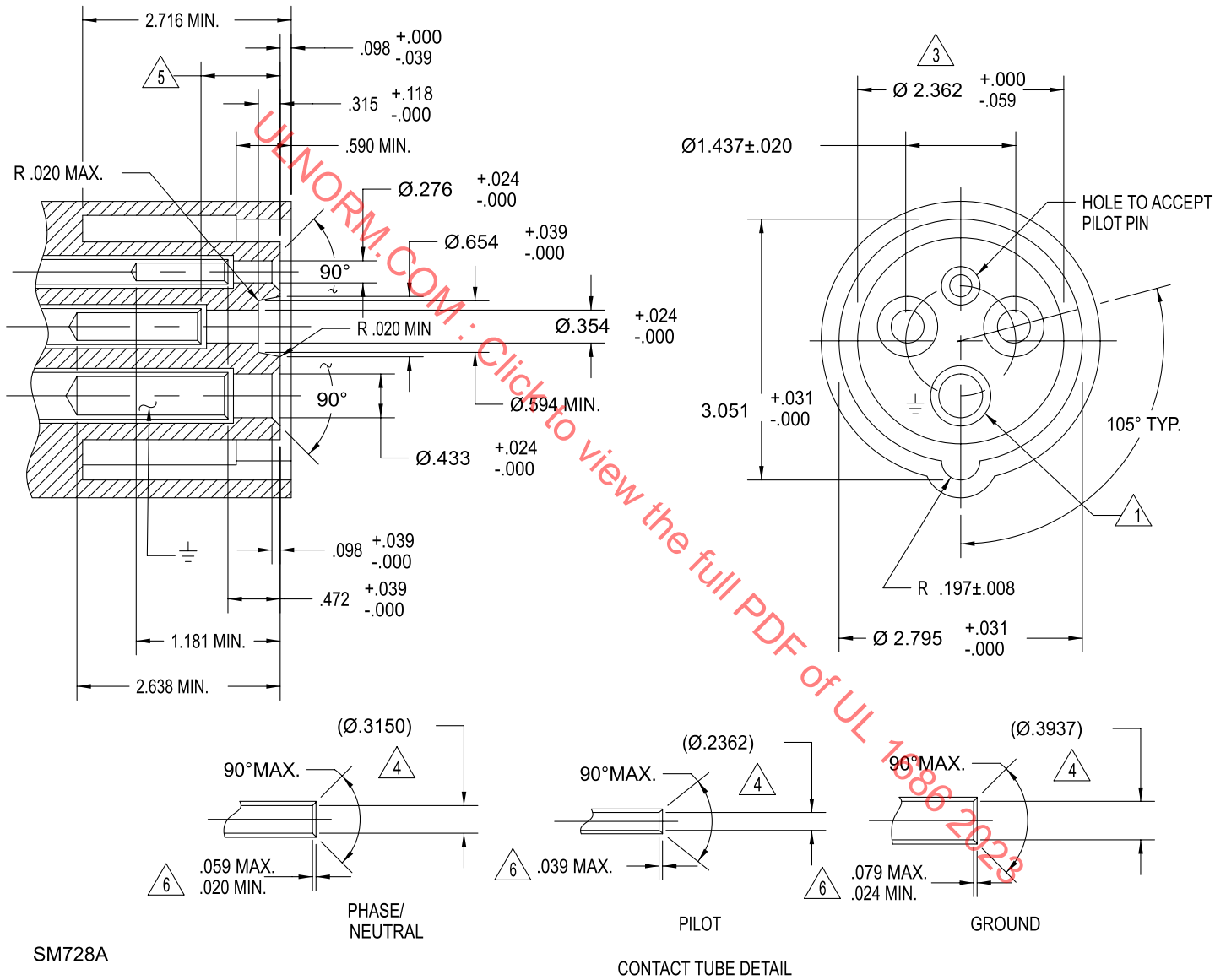
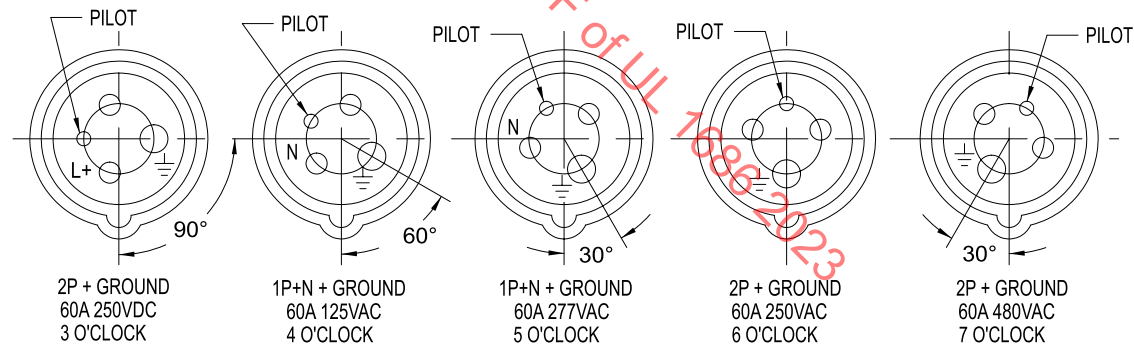

Figure C2.15  
Receptacle or Connector  
60 Ampere, 3 Wire With Pilot

- 1. MAIN VIEW SHOWN WITH GROUND AT 6 O'CLOCK POSITION FOR REFERENCE ONLY. SEE RATING CONFIGURATION FOR RELEVANT POSITIONS.
- 2. HOLES OR RECESSES IN THE FRONTAL FACE, IF ANY, OTHER THAN THOSE FOR CONTACT TUBES, SHALL HAVE A DEPTH OF NOT MORE THAN .394 INCHES. (EXCEPTION: SEE NOTE 3)
- 3. THIS DIMENSION SHALL NOT EXCEED THE PRESCRIBED LIMIT AT ANY POINT OVER THE WHOLE DEPTH, AND SHALL BE WITHIN THE PRESCRIBED LIMITS OVER A MINIMUM DEPTH OF .236 INCHES WITH THE EXCEPTION OF A MAXIMUM OF 3 CUT-OUTS SPACED AROUND THE CIRCUMFERENCE WITH NOT MORE THAN ONE CUT-OUT BETWEEN ADJACENT HOLES FOR THE CONTACT TUBES AND EACH HAVING A WIDTH NOT EXCEEDING .590 INCHES INCLUDING ANY RADII. HOLES DEEPER THAN .394 INCHES IN THE AREA ARE ALLOWED.
- 4. DIMENSIONS REFER TO PIN DIAMETERS; THE CONTACTS TUBES NEED NOT BE CIRCULAR.
- 5. THIS DIMENSION IS AS FOLLOWS:  
ELECTRIC INTERLOCK -- .827  
MECHANICAL INTERLOCK -- .827 TO 1.575  
WITHOUT INTERLOCK -- .827 TO 1.575
- 6. THE BEVELLING OF THE CONTACTS TUBES MAY BE ROUNDED OFF TOWARDS THE INTERNAL CYLINDRICAL SURFACE WITHIN A DISTANCE OF 1-1/2 TIMES THE MAXIMUM DIMENSION.
- 7.  $\perp$  DENOTES EQUIPMENT GROUND CONTACT. TERMINAL SHALL BE IDENTIFIED BY THE WORD "GREEN" AND/OR COLOR GREEN. TERMINAL MAY BE ADDITIONALLY IDENTIFIED BY EARTH SYMBOL ( $\perp$ ).
- 8. N DENOTES GROUNDED LINE CONDUCTOR CONTACT. TERMINAL SHALL BE IDENTIFIED BY THE WORD "WHITE" AND/OR COLOR WHITE. TERMINAL MAY BE ADDITIONALLY IDENTIFIED BY THE LETTER "N".

Figure C2.15 (Cont.)

RATING CONFIGURATIONS  
FRONT VIEW - RECEPTACLE OR CONNECTOR



SM729A

(Continued)

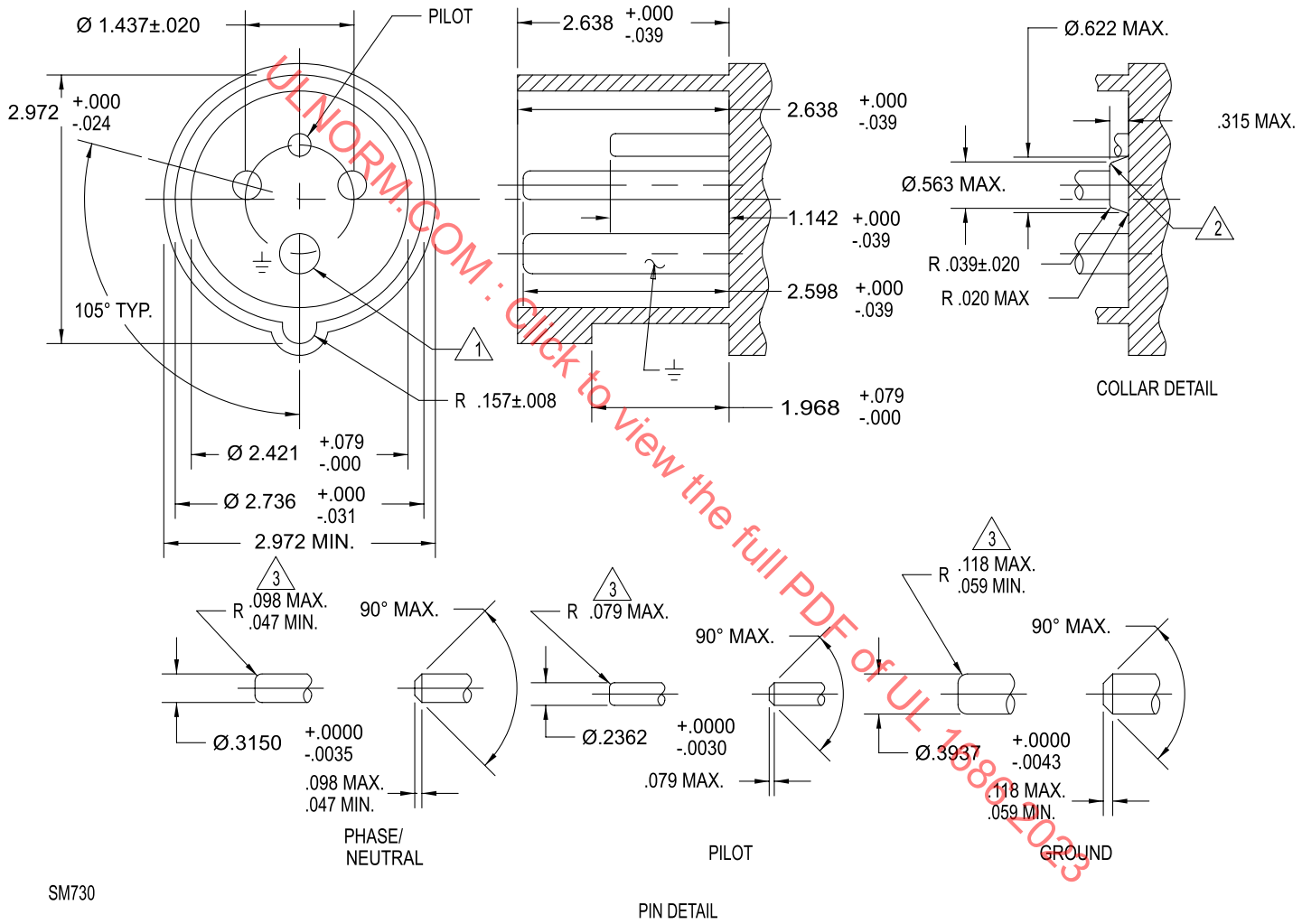

SM730

Figure C2.16  
Plug or Inlet  
60 Ampere, 3 Wire With Pilot

- 1 MAIN VIEW SHOWN WITH GROUND AT 6 O'CLOCK POSITION FOR REFERENCE ONLY. SEE RATING CONFIGURATION FOR RELEVANT POSITIONS.
- 2 COLLARS REQUIRED FOR DEVICES HAVING RATED OPERATING VOLTAGES EXCEEDING 500 V, OPTIONAL FOR OTHER DEVICES.
- 3 ENDS OF PINS MAY BE ROUNDED OFF TOWARDS THE EXTERNAL CYLINDRICAL SURFACE WITHIN A DISTANCE OF 1-1/2 TIMES OF THE MAXIMUM DIMENSION.

- 4.  $\perp$  DENOTES EQUIPMENT GROUND CONTACT. TERMINAL SHALL BE IDENTIFIED BY THE WORD "GREEN" AND/OR COLOR GREEN. TERMINAL MAY BE ADDITIONALLY IDENTIFIED BY EARTH SYMBOL ( $\perp$ ).
- 5. N DENOTES GROUNDED LINE CONDUCTOR CONTACT. TERMINAL SHALL BE IDENTIFIED BY THE WORD "WHITE" AND/OR COLOR WHITE. TERMINAL MAY BE ADDITIONALLY IDENTIFIED BY THE LETTER "N".

RATING CONFIGURATIONS  
FRONT VIEW - PLUG OR INLET

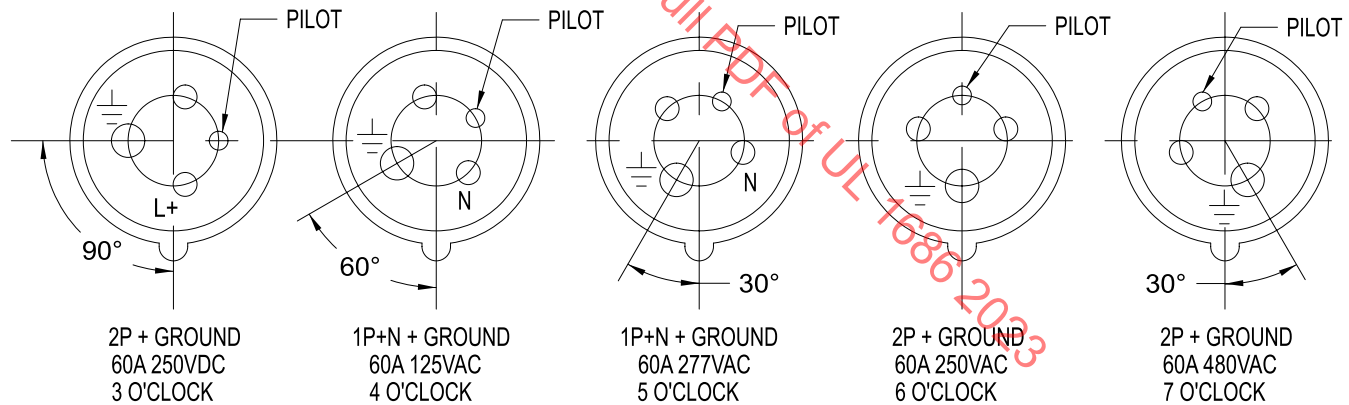

SM731

Figure C2.16 (Cont.)



- 1. MAIN VIEW SHOWN WITH GROUND AT 6 O'CLOCK POSITION FOR REFERENCE ONLY. SEE RATING CONFIGURATION FOR RELEVANT POSITIONS.
- 2. HOLES OR RECESSES IN THE FRONTAL FACE, IF ANY, OTHER THAN THOSE FOR CONTACT TUBES, SHALL HAVE A DEPTH OF NOT MORE THAN .394 INCHES (EXCEPTION: SEE NOTE 3)
- 3. THIS DIMENSION SHALL NOT EXCEED THE PRESCRIBED LIMIT AT ANY POINT OVER THE WHOLE DEPTH, AND SHALL BE WITHIN THE PRESCRIBED LIMITS OVER A MINIMUM DEPTH OF .236 INCHES WITH THE EXCEPTION OF A MAXIMUM OF 3 CUT-OUTS SPACED AROUND THE CIRCUMFERENCE WITH NOT MORE THAN ONE CUT-OUT BETWEEN ADJACENT HOLES FOR THE CONTACT TUBES AND EACH HAVING A WIDTH NOT EXCEEDING .590 INCHES INCLUDING ANY RADII. HOLES DEEPER THAN .394 INCHES IN THE AREA ARE ALLOWED.
- 4. DIMENSIONS REFER TO PIN DIAMETERS: THE CONTACTS TUBES NEED NOT BE CIRCULAR.
- 5. THE DIMENSION IS AS FOLLOWS:  
ELECTRICAL INTERLOCK -- .827  
MECHANICAL INTERLOCK -- .827 TO 1.575  
WITHOUT INTERLOCK -- .827 TO 1.575
- 6. THE BEVELLING OF THE CONTACTS TUBES MAY BE ROUNDED OFF TOWARDS THE INTERNAL CYLINDRICAL SURFACE WITHIN A DISTANCE OF 1-1/2 TIMES THE MAXIMUM DIMENSIONS.
- 7. ≠ DENOTES EQUIPMENT GROUND CONTACT. TERMINAL SHALL BE IDENTIFIED BY THE WORD "GREEN" AND/OR COLOR GREEN. TERMINAL MAY BE ADDITIONALLY IDENTIFIED BY EARTH SYMBOL (≡).
- 8. N DENOTES GROUNDED LINE CONDUCTOR CONTACT. TERMINAL SHALL BE IDENTIFIED BY THE WORD "WHITE" AND/OR COLOR WHITE. TERMINAL MAY BE ADDITIONALLY IDENTIFIED BY THE LETTER "N".

Figure C2.17 (Cont.)

FIGURE C2.17 (CONT.)

RATING CONFIGURATIONS  
FRONT VIEW - RECEPTACLE OR CONNECTOR

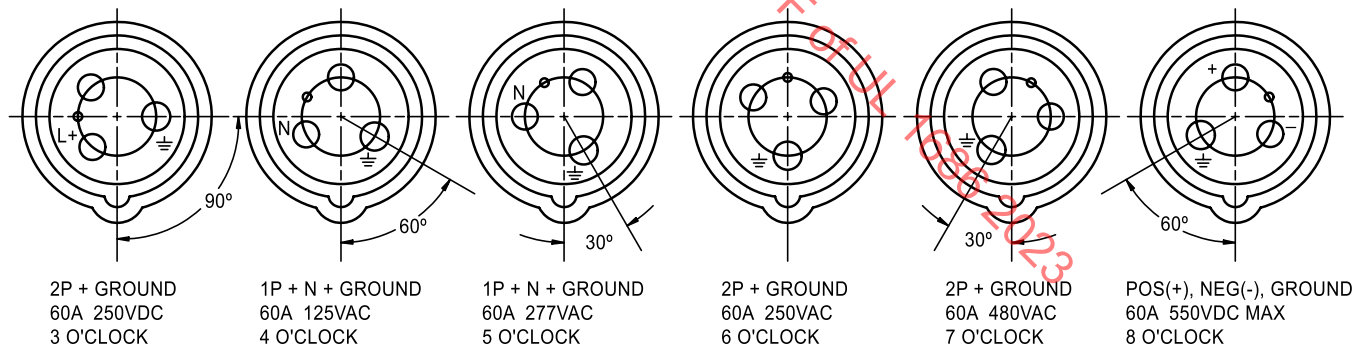

su0700

(Continued)

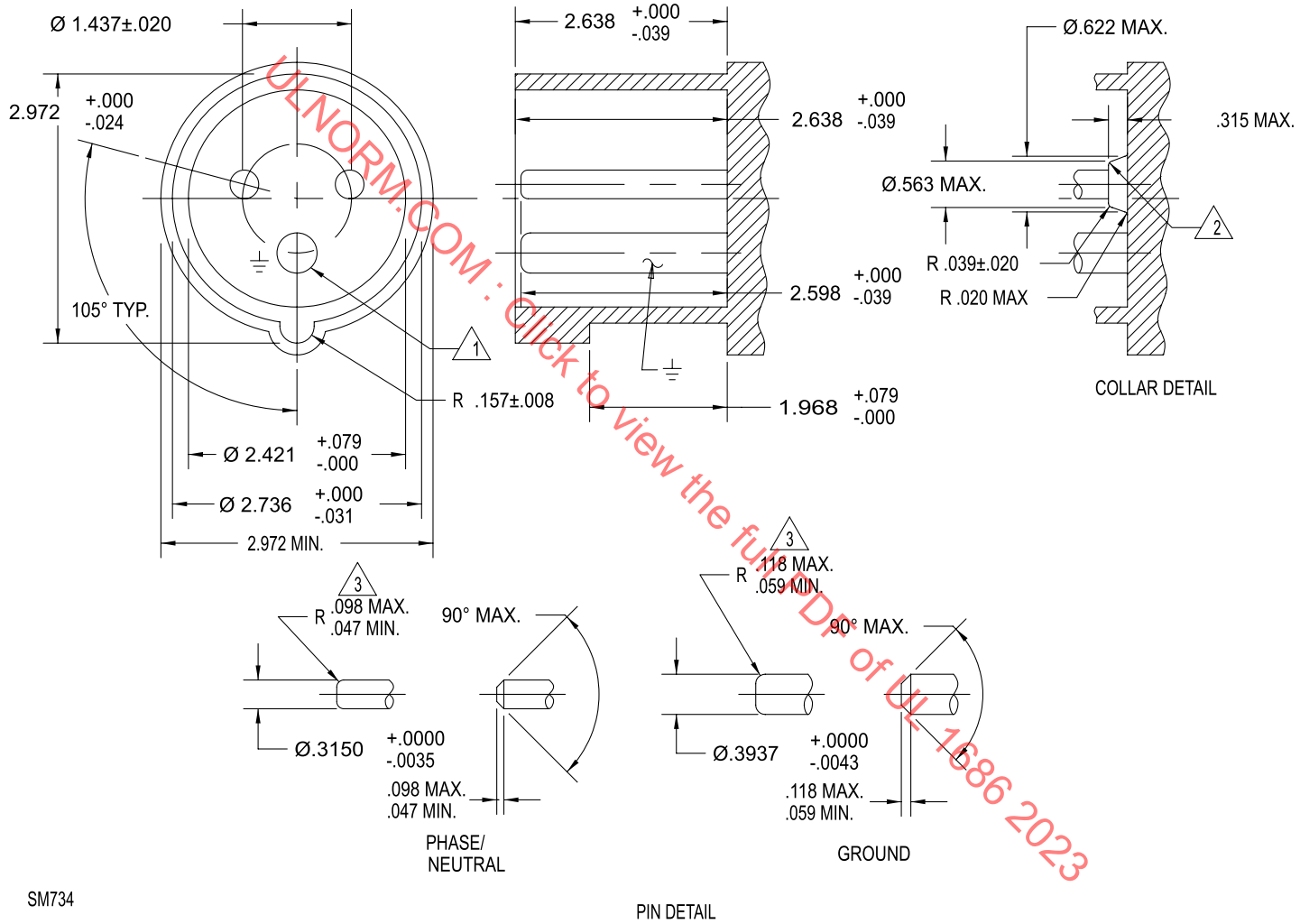

SM734

Figure C2.18  
Plug or Inlet  
60 Ampere, 3 Wire Without Pilot

- 1. MAIN VIEW SHOWN WITH GROUND AT 6 O'CLOCK POSITION FOR REFERENCE ONLY. SEE RATING CONFIGURATION FOR RELEVANT POSITIONS.
- 2. COLLARS REQUIRED FOR DEVICES HAVING RATED OPERATING VOLTAGES EXCEEDING 500 V. OPTIONAL FOR OTHER DEVICES.
- 3. END OF PINS MAY BE ROUNDED OFF TOWARDS THE EXTERNAL CYLINDRICAL SURFACE WITHIN A DISTANCE OF 1-1/2 TIMES OF THE MAXIMUM DIMENSION.
- 4.  $\equiv$  DENOTES EQUIPMENT GROUND CONTACT. TERMINAL SHALL BE IDENTIFIED BY THE WORD "GREEN" AND/OR COLOR GREEN. TERMINAL MAY BE ADDITIONALLY IDENTIFIED BY EARTH SYMBOL ( $\equiv$ ).
- 5. N DENOTES GROUNDED LINE CONDUCTOR CONTACT. TERMINAL SHALL BE IDENTIFIED BY THE WORD "WHITE" AND/OR COLOR WHITE. TERMINAL MAY BE ADDITIONALLY IDENTIFIED BY THE LETTER "N".

Figure C2.18 (Cont.)

FIGURE C2.18 (CONT.)

RATING CONFIGURATIONS  
FRONT VIEW - PLUG OR INLET

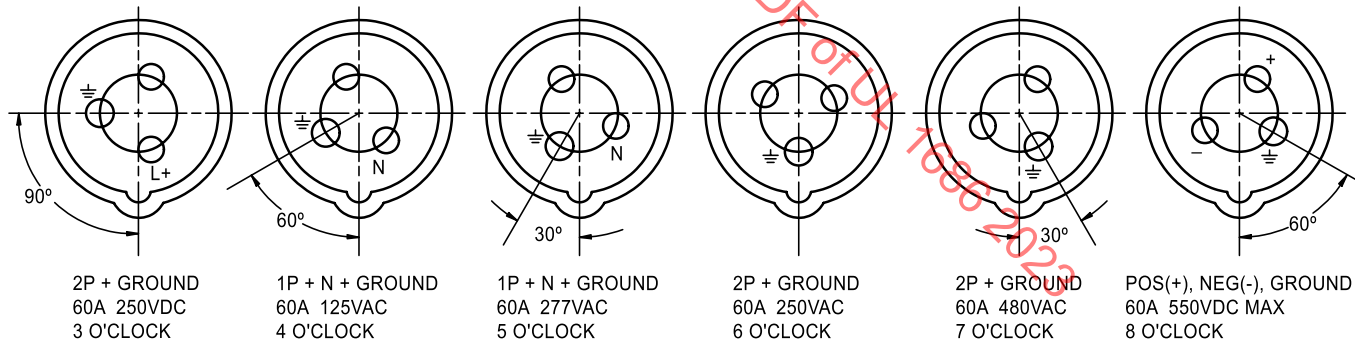

su0701

(Continued)

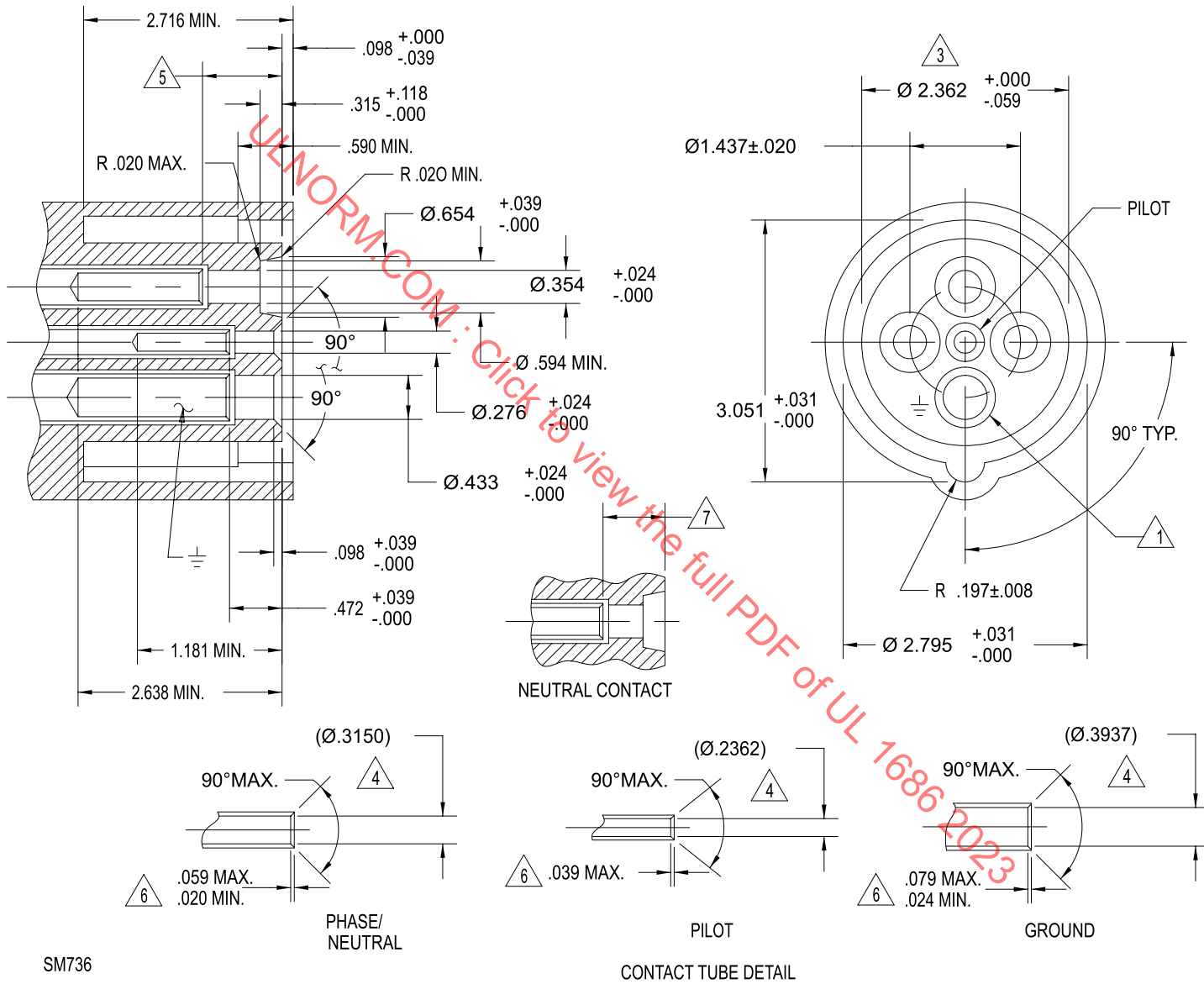

SM736

Figure C2.19  
Receptacle or Connector  
60 Ampere, 4 Wire With Pilot

Figure C2.19 (Cont.)

- 1. MAIN VIEW SHOWN WITH GROUND AT 6 O'CLOCK POSITION FOR REFERENCE ONLY. SEE RATING CONFIGURATION FOR RELEVANT POSITIONS.
- 2. HOLES OR RECESSES IN THE FRONTAL FACE, IF ANY, OTHER THAN THOSE FOR CONTACT TUBES, SHALL HAVE A DEPTH OF NOT MORE THAN .394 INCHES. (EXCEPTIONS: SEE NOTE 3)
- 3. THIS DIMENSION SHALL NOT EXCEED THE PRESCRIBED LIMIT AT ANY POINT OVER THE WHOLE DEPTH, AND SHALL BE WITHIN THE PRESCRIBED LIMITS OVER A MINIMUM DEPTH OF .236 INCHES WITH THE EXCEPTION OF A MAXIMUM OF 4 CUT-OUTS SPACED AROUND THE CIRCUMFERENCE WITH NOT MORE THAN ONE CUT-OUT BETWEEN ADJACENT HOLES FOR THE CONTACT TUBES AND EACH HAVING A WIDTH NOT EXCEEDING .590 INCHES INCLUDING ANY RADII. HOLES DEEPER THAN .394 INCHES IN THE AREA ARE ALLOWED.
- 4. DIMENSIONS REFER TO PIN DIAMETERS; THE CONTACTS TUBES NEED NOT BE CIRCULAR.
- 5. THIS DIMENSION IS AS FOLLOWS:  
ELECTRIC INTERLOCK -- .827  
MECHANICAL INTERLOCK -- .827 TO 1.575  
WITHOUT INTERLOCK -- .827 TO 1.575
- 6. THE BEVELLING OF THE CONTACTS TUBES MAY BE ROUNDED OFF TOWARDS THE INTERNAL CYLINDRICAL SURFACE WITHIN A DISTANCE OF 1-1/2 TIMES THE MAXIMUM DIMENSION.
- 7. NEUTRAL CONTACT WHEN REQUIRED SHALL BE LESS THAN THE PHASE BUT MORE THAN THE GROUND FROM THE FRONTAL FACE.
- 8.  $\perp$  DENOTES EQUIPMENT GROUND CONTACT. TERMINAL SHALL BE IDENTIFIED BY THE WORD "GREEN" AND/OR COLOR GREEN. TERMINAL MAY BE ADDITIONALLY IDENTIFIED BY EARTH SYMBOL ( $\perp$ ).
- 9. N DENOTES GROUNDED LINE CONDUCTOR CONTACT. TERMINAL SHALL BE IDENTIFIED BY THE WORD "WHITE" AND/OR COLOR WHITE. TERMINAL MAY BE ADDITIONALLY IDENTIFIED BY THE LETTER "N".

RATING CONFIGURATIONS  
FRONT VIEW - RECEPTACLE OR CONNECTOR

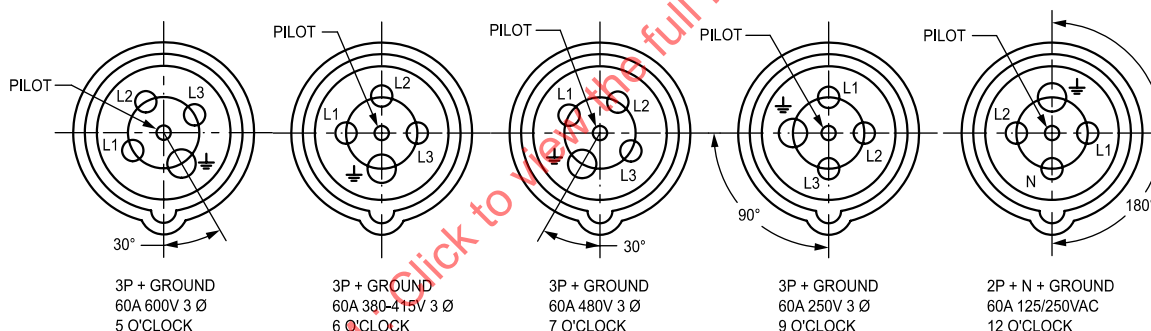

su1360

(Continued)

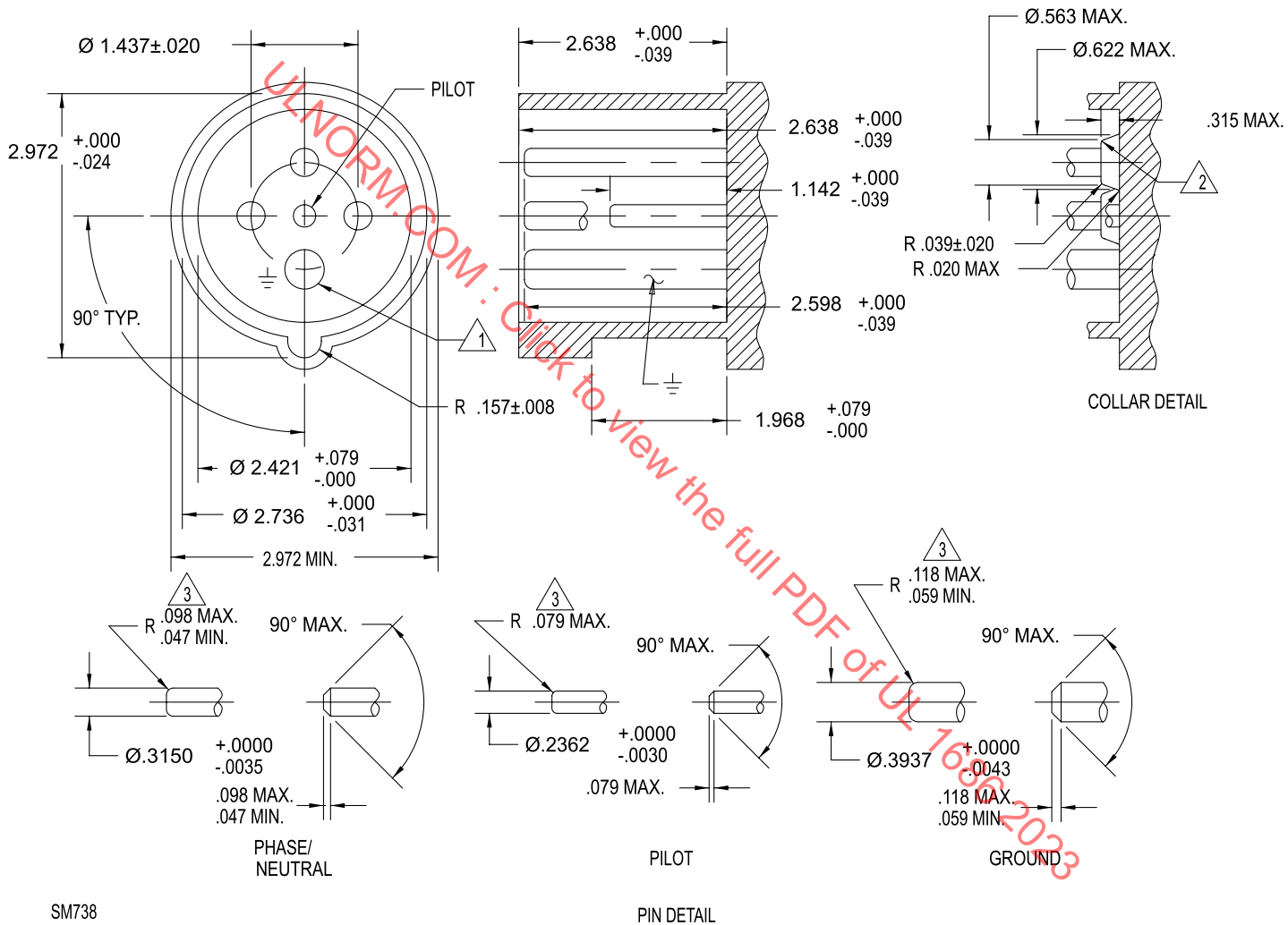

- 1 MAIN VIEW SHOWN WITH GROUND AT 6 O'CLOCK POSITION FOR REFERENCE ONLY. SEE RATING CONFIGURATION FOR RELEVANT POSITIONS.
- 2 COLLARS REQUIRED FOR DEVICES HAVING RATED OPERATING VOLTAGES EXCEEDING 500 V, OPTIONAL FOR OTHER DEVICES.
- 3 ENDS OF PINS MAY BE ROUNDED OFF TOWARDS THE EXTERNAL CYLINDRICAL SURFACE WITHIN A DISTANCE OF 1-1/2 TIMES OF THE MAXIMUM DIMENSION.

- 4  $\perp$  DENOTES EQUIPMENT GROUND CONTACT. TERMINAL SHALL BE IDENTIFIED BY THE WORD "GREEN" AND/OR COLOR GREEN. TERMINAL MAY BE ADDITIONALLY IDENTIFIED BY EARTH SYMBOL ( $\perp$ ).
- 5 N DENOTES GROUNDED LINE CONDUCTOR CONTACT. TERMINAL SHALL BE IDENTIFIED BY THE WORD "WHITE" AND/OR COLOR WHITE. TERMINAL MAY BE ADDITIONALLY IDENTIFIED BY THE LETTER "N".

RATING CONFIGURATIONS  
FRONT VIEW - PLUG OR INLET

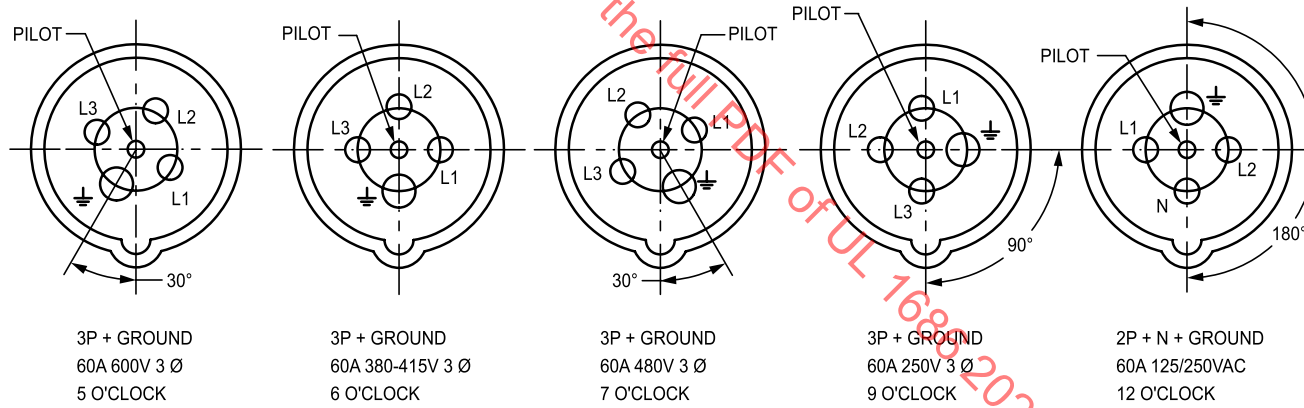

su1361

Figure C2.20 (Cont.)

(Continued)

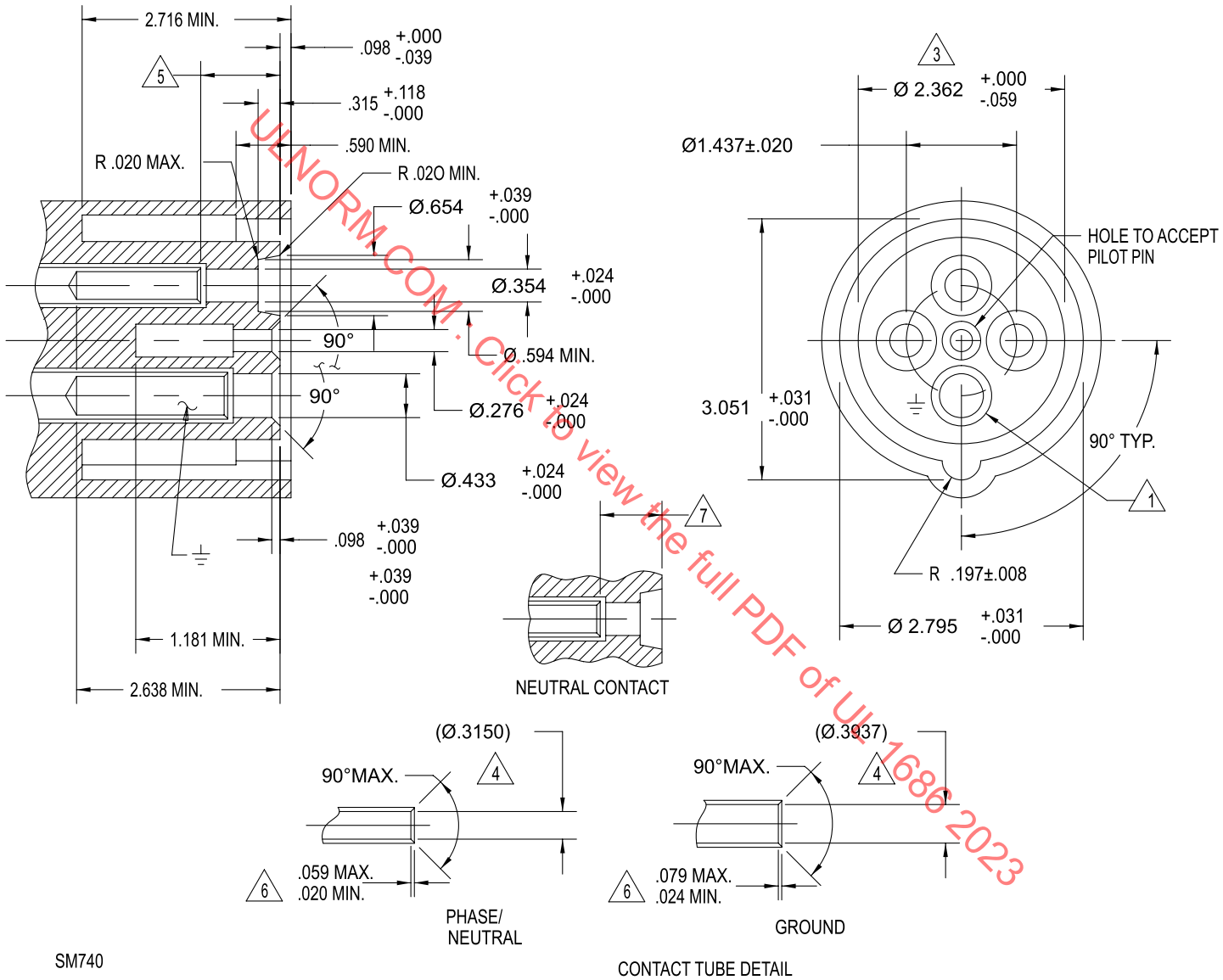

SM740

60 Ampere, 4 Wire Without Pilot  
Receptacle or Connector

Figure C2.21

- 1. MAIN VIEW SHOWN WITH GROUND AT 6 O'CLOCK POSITION FOR REFERENCE ONLY. SEE RATING CONFIGURATION FOR RELEVANT POSITIONS.
- 2. HOLES OR RECESSES IN THE FRONTAL FACE, IF ANY, OTHER THAN THOSE FOR CONTACT TUBES, SHALL HAVE A DEPTH OF NOT MORE THAN .394 INCHES. (EXCEPTIONS: SEE NOTE 3)
- 3. THIS DIMENSION SHALL NOT EXCEED THE PRESCRIBED LIMIT AT ANY POINT OVER THE WHOLE DEPTH, AND SHALL BE WITHIN THE PRESCRIBED LIMITS OVER A MINIMUM DEPTH OF .236 INCHES WITH THE EXCEPTION OF A MAXIMUM OF 4 CUT-OUTS SPACED AROUND THE CIRCUMFERENCE WITH NOT MORE THAN ONE CUT-OUT BETWEEN ADJACENT HOLES FOR THE CONTACT TUBES AND EACH HAVING A WIDTH NOT EXCEEDING .590 INCHES INCLUDING ANY RADII. HOLES DEEPER THAN .394 INCHES IN THE AREA ARE ALLOWED.
- 4. DIMENSIONS REFER TO PIN DIAMETERS; THE CONTACTS TUBES NEED NOT BE CIRCULAR.
- 5. THIS DIMENSION IS AS FOLLOWS:  
ELECTRIC INTERLOCK -- .827  
MECHANICAL INTERLOCK -- .827 TO 1.575  
WITHOUT INTERLOCK -- .827 TO 1.575
- 6. THE BEVELLING OF THE CONTACTS TUBES MAY BE ROUNDED OFF TOWARDS THE INTERNAL CYLINDRICAL SURFACE WITHIN A DISTANCE OF 1-1/2 TIMES THE MAXIMUM DIMENSION.
- 7. NEUTRAL CONTACT WHEN REQUIRED SHALL BE LESS THAN THE PHASE BUT MORE THAN THE GROUND FROM THE FRONTAL FACE.
- 8.  $\perp$  DENOTES EQUIPMENT GROUND CONTACT. TERMINAL SHALL BE IDENTIFIED BY THE WORD "GREEN" AND/OR COLOR GREEN. TERMINAL MAY BE ADDITIONALLY IDENTIFIED BY EARTH SYMBOL ( $\perp$ ).
- 9. N DENOTES GROUNDED LINE CONDUCTOR CONTACT. TERMINAL SHALL BE IDENTIFIED BY THE WORD "WHITE" AND/OR COLOR WHITE. TERMINAL MAY BE ADDITIONALLY IDENTIFIED BY THE LETTER "N".

RATING CONFIGURATIONS  
FRONT VIEW - RECEPTACLE OR CONNECTOR

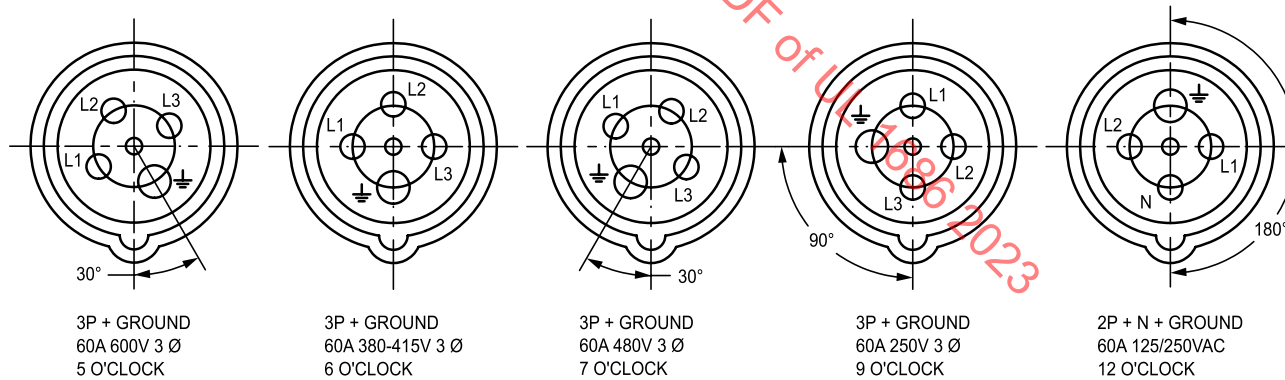

su1362

Figure C2.21 (Cont.)

(Continued)

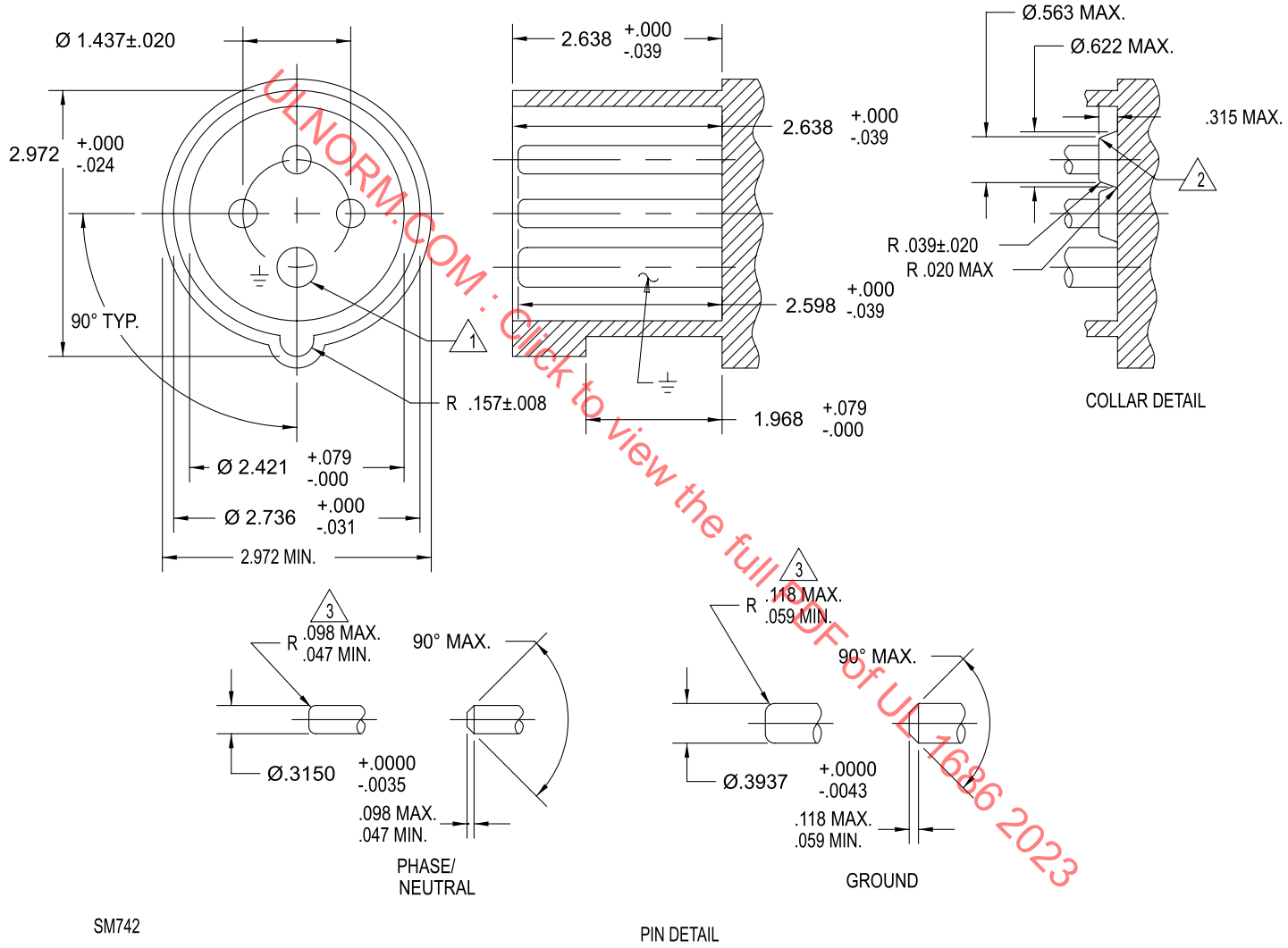

SM742

PIN DETAIL

60 Ampere, 4 Wire Without Pilot Plug or Inlet

Figure C2.22

- 1. MAIN VIEW SHOWN WITH GROUND AT 6 O'CLOCK POSITION FOR REFERENCE ONLY. SEE RATING CONFIGURATION FOR RELEVANT POSITIONS.
- 2. COLLARS REQUIRED FOR DEVICES HAVING RATED OPERATING VOLTAGES EXCEEDING 500 V, OPTIONAL FOR OTHER DEVICES.
- 3. ENDS OF PINS MAY BE ROUNDED OFF TOWARDS THE EXTERNAL CYLINDRICAL SURFACE WITHIN A DISTANCE OF 1-1/2 TIMES OF THE MAXIMUM DIMENSION.
- 4.  $\perp$  DENOTES EQUIPMENT GROUND CONTACT. TERMINAL SHALL BE IDENTIFIED BY THE WORD "GREEN" AND/OR COLOR GREEN. TERMINAL MAY BE ADDITIONALLY IDENTIFIED BY EARTH SYMBOL ( $\perp$ ).
- 5. N DENOTES GROUNDED LINE CONDUCTOR CONTACT. TERMINAL SHALL BE IDENTIFIED BY THE WORD "WHITE" AND/OR COLOR WHITE. TERMINAL MAY BE ADDITIONALLY IDENTIFIED BY THE LETTER "N".

RATING CONFIGURATIONS  
FRONT VIEW - PLUG OR INLET

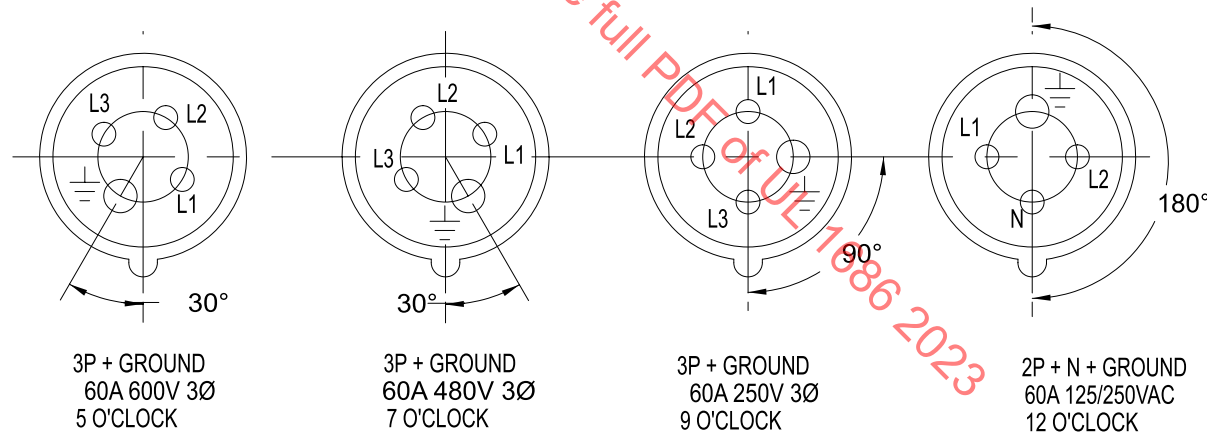

SM743A

Figure C2.22 (Cont.)

(Continued)

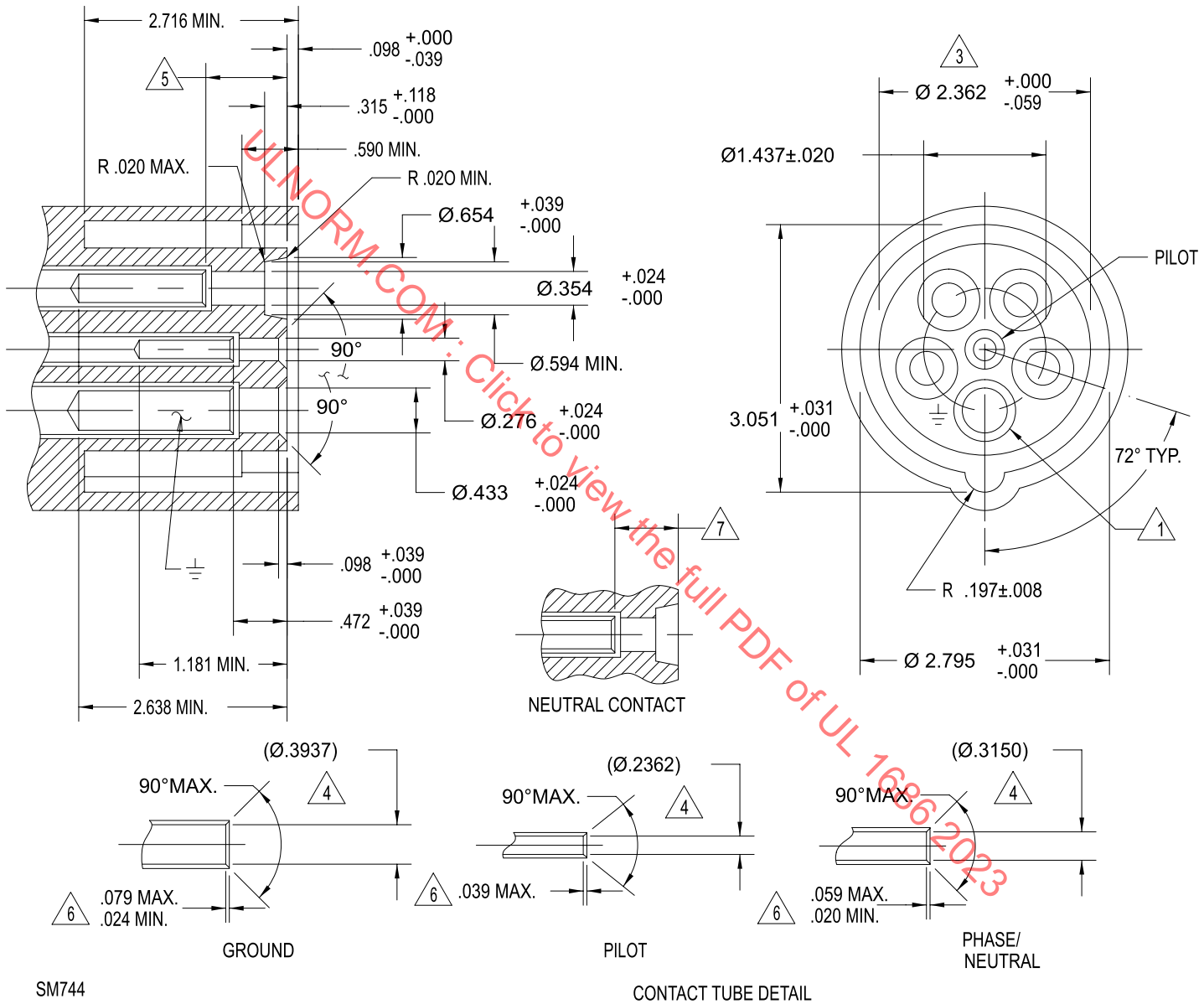

SM744

Figure C2.23  
Receptacle or Connector  
60 Ampere, 5 Wire With Pilot

- 1. MAIN VIEW SHOWN WITH GROUND AT 6 O'CLOCK POSITION FOR REFERENCE ONLY. SEE RATING CONFIGURATION FOR RELEVANT POSITIONS.
- 2. HOLES OR RECESSES IN THE FRONTAL FACE, IF ANY, OTHER THAN THOSE FOR CONTACT TUBES, SHALL HAVE A DEPTH OF NOT MORE THAN .394 INCHES. (EXCEPTION: SEE NOTE 3)
- 3. THIS DIMENSION SHALL NOT EXCEED THE PRESCRIBED LIMIT AT ANY POINT OVER THE WHOLE DEPTH, AND SHALL BE WITHIN THE PRESCRIBED LIMITS OVER A MINIMUM DEPTH OF .236 INCHES WITH THE EXCEPTION OF A MAXIMUM OF 5 CUT-OUTS SPACED AROUND THE CIRCUMFERENCE WITH NOT MORE THAN ONE CUT-OUT BETWEEN ADJACENT HOLES FOR THE CONTACT TUBES AND EACH HAVING A WIDTH NOT EXCEEDING .590 INCHES INCLUDING ANY RADII. HOLES DEEPER THAN .394 INCHES IN THE AREA ARE ALLOWED.
- 4. DIMENSIONS REFER TO PIN DIAMETERS; THE CONTACTS TUBES NEED NOT BE CIRCULAR.
- 5. THIS DIMENSION IS AS FOLLOWS:  
ELECTRIC INTERLOCK -- .827  
MECHANICAL INTERLOCK -- .827 TO 1.575  
WITHOUT INTERLOCK -- .827 TO 1.575
- 6. THE BEVELLING OF THE CONTACTS TUBES MAY BE ROUNDED OFF TOWARDS THE INTERNAL CYLINDRICAL SURFACE WITHIN A DISTANCE OF 1-1/2 TIMES THE MAXIMUM DIMENSION.
- 7. NEUTRAL CONTACT WHEN REQUIRED SHALL BE LESS THAN THE PHASE BUT MORE THAN THE GROUND FROM THE FRONTAL FACE.
- 8.  $\perp$  DENOTES EQUIPMENT GROUND CONTACT. TERMINAL SHALL BE IDENTIFIED BY THE WORD "GREEN" AND/OR COLOR GREEN. TERMINAL MAY BE ADDITIONALLY IDENTIFIED BY EARTH SYMBOL ( $\perp$ ).
- 9. N DENOTES GROUNDED LINE CONDUCTOR CONTACT. TERMINAL SHALL BE IDENTIFIED BY THE WORD "WHITE" AND/OR COLOR WHITE. TERMINAL MAY BE ADDITIONALLY IDENTIFIED BY THE LETTER "N".

FIGURE C2.23 (CONT.)

Figure C2.23 (Cont.)

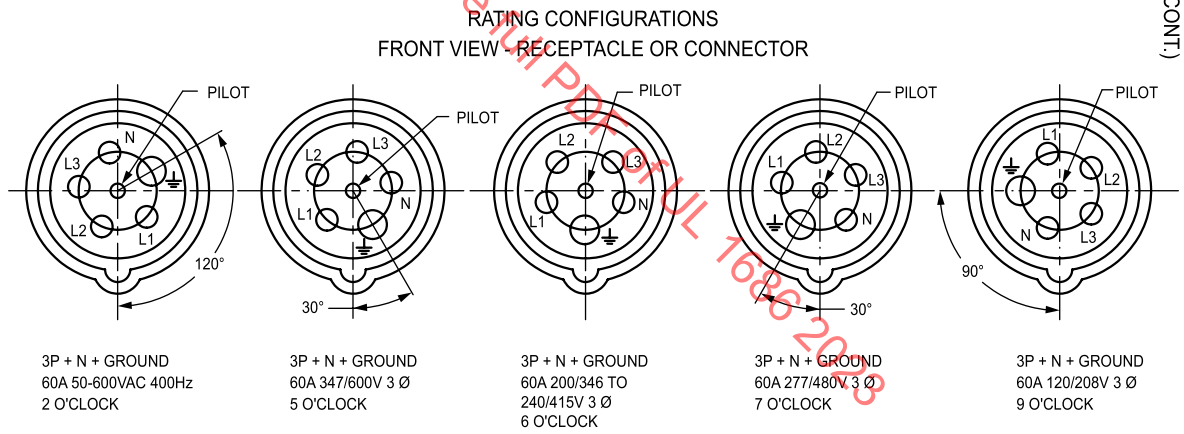

su1363

(Continued)

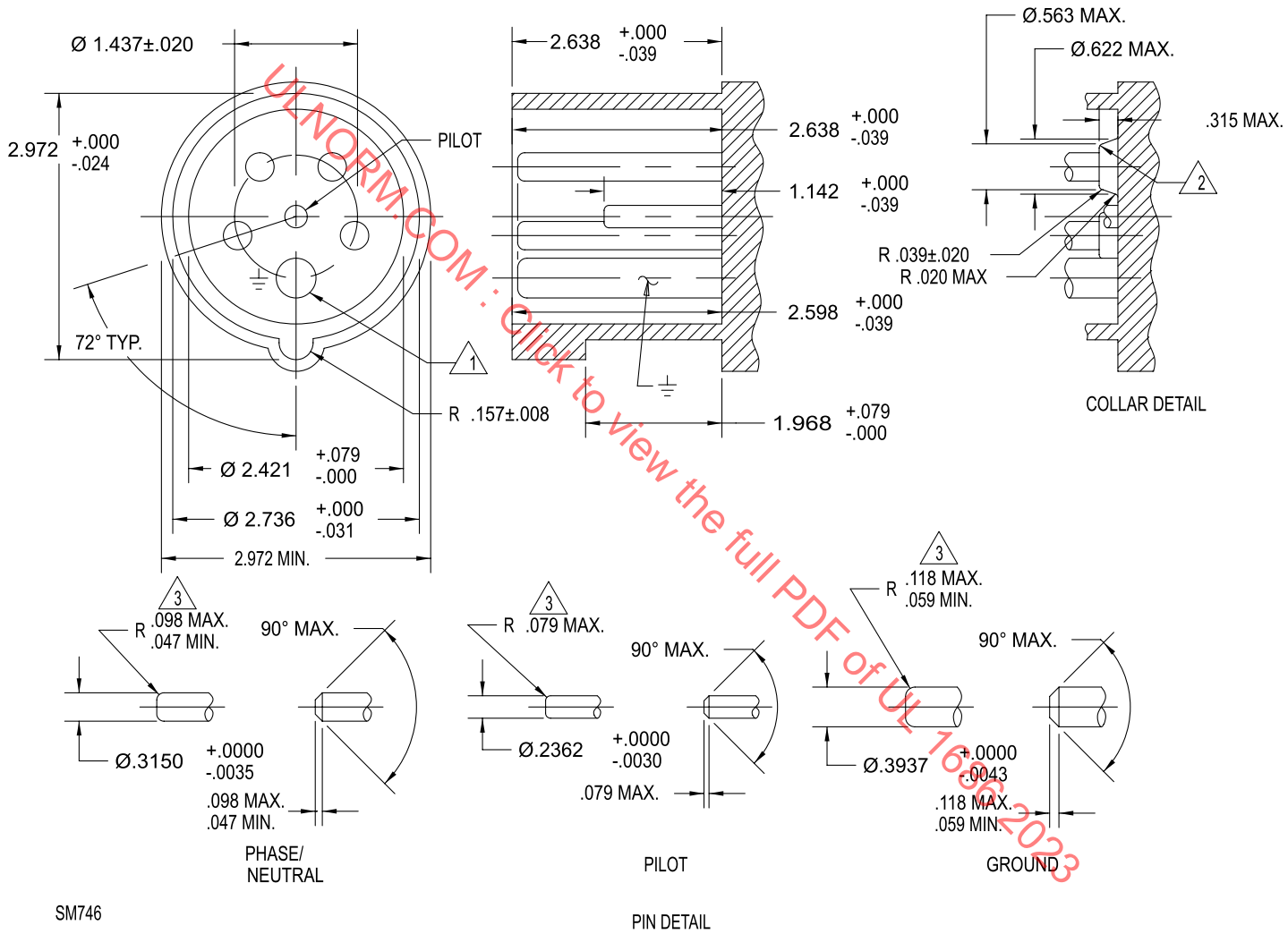

SM746

Figure C2.24  
Plug or Inlet  
60 Ampere, 5 Wire With Pilot

- 1. MAIN VIEW SHOWN WITH GROUND AT 6 O'CLOCK POSITION FOR REFERENCE ONLY. SEE RATING CONFIGURATION FOR RELEVANT POSITIONS.
- 2. COLLARS REQUIRED FOR DEVICES HAVING RATED OPERATING VOLTAGES EXCEEDING 500 V, OPTIONAL FOR OTHER DEVICES.
- 3. ENDS OF PINS MAY BE ROUNDED OFF TOWARDS THE EXTERNAL CYLINDRICAL SURFACE WITHIN A DISTANCE OF 1-1/2 TIMES OF THE MAXIMUM DIMENSION.
- 4.  $\perp$  DENOTES EQUIPMENT GROUND CONTACT. TERMINAL SHALL BE IDENTIFIED BY THE WORD "GREEN" AND/OR COLOR GREEN. TERMINAL MAY BE ADDITIONALLY IDENTIFIED BY EARTH SYMBOL ( $\perp$ ).
- 5. N DENOTES GROUNDED LINE CONDUCTOR CONTACT. TERMINAL SHALL BE IDENTIFIED BY THE WORD "WHITE" AND/OR COLOR WHITE. TERMINAL MAY BE ADDITIONALLY IDENTIFIED BY THE LETTER "N".

RATING CONFIGURATIONS  
FRONT VIEW - PLUG OR INLET

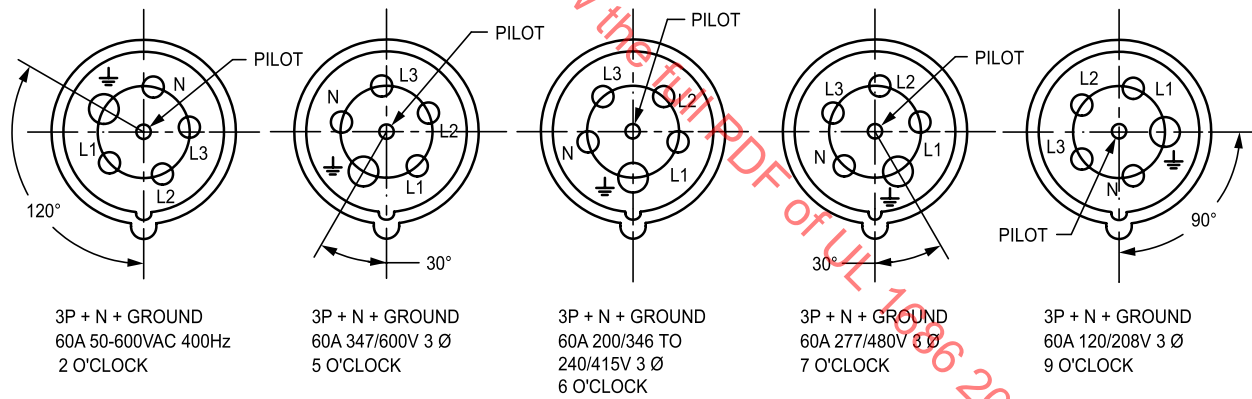

su1364

Figure C2.24 (Cont.)

(Continued)

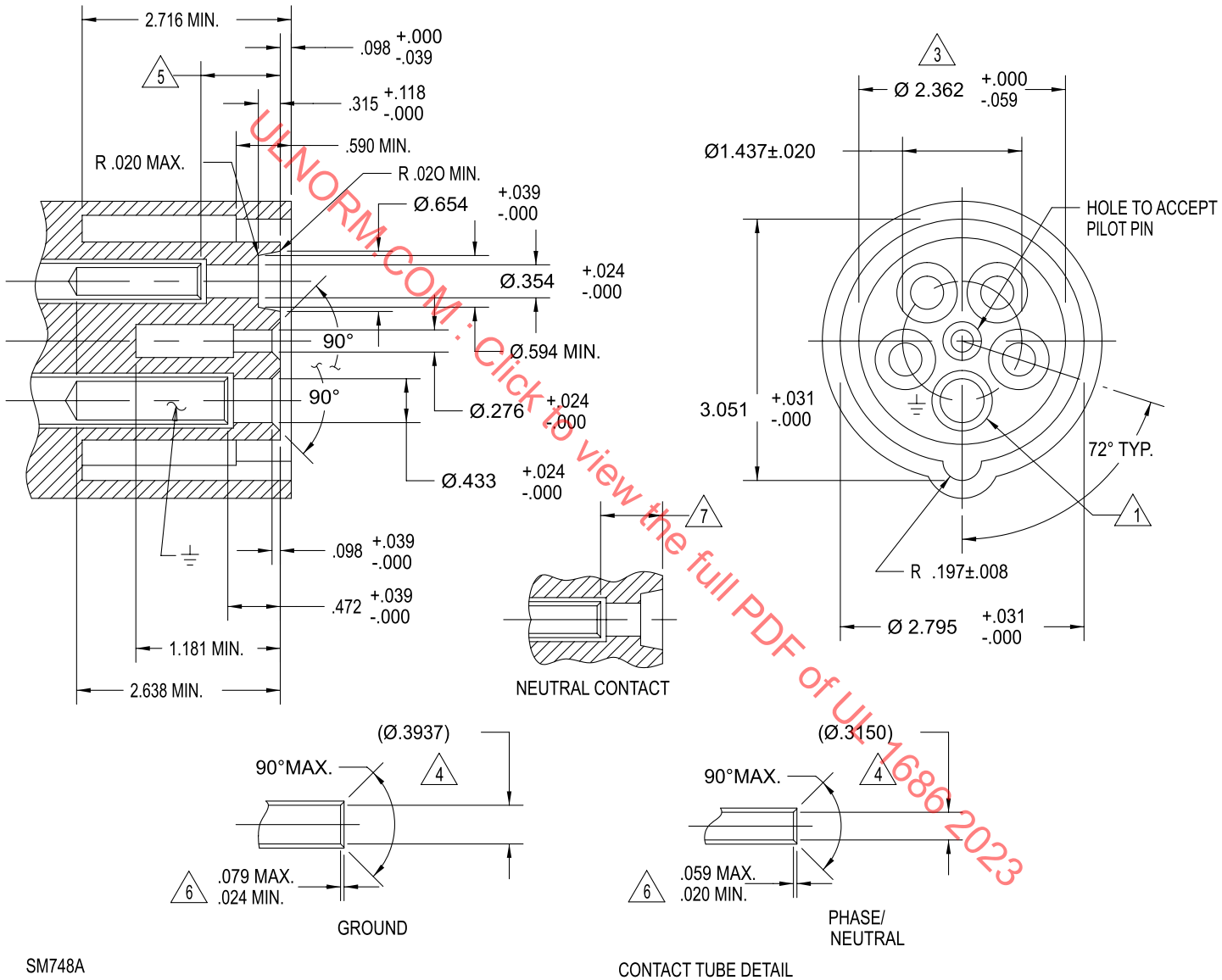

SM748A

Figure C2.25  
Receptacle or Connector  
60 Ampere, 5 Wire Without Pilot

- 1. MAIN VIEW SHOWN WITH GROUND AT 6 O'CLOCK POSITION FOR REFERENCE ONLY. SEE RATING CONFIGURATION FOR RELEVANT POSITIONS.
- 2. HOLES OR RECESSES IN THE FRONTAL FACE, IF ANY, OTHER THAN THOSE FOR CONTACT TUBES, SHALL HAVE A DEPTH OF NOT MORE THAN .394 INCHES. (EXCEPTION: SEE NOTE 3)
- 3. THIS DIMENSION SHALL NOT EXCEED THE PRESCRIBED LIMIT AT ANY POINT OVER THE WHOLE DEPTH, AND SHALL BE WITHIN THE PRESCRIBED LIMITS OVER A MINIMUM DEPTH OF .236 INCHES WITH THE EXCEPTION OF A MAXIMUM OF 5 CUT-OUTS SPACED AROUND THE CIRCUMFERENCE WITH NOT MORE THAN ONE CUT-OUT BETWEEN ADJACENT HOLES FOR THE CONTACT TUBES AND EACH HAVING A WIDTH NOT EXCEEDING .590 INCHES INCLUDING ANY RADII. HOLES DEEPER THAN .394 INCHES IN THE AREA ARE ALLOWED.
- 4. DIMENSIONS REFER TO PIN DIAMETERS; THE CONTACTS TUBES NEED NOT BE CIRCULAR.
- 5. THIS DIMENSION IS AS FOLLOWS:  
ELECTRIC INTERLOCK - - .827  
MECHANICAL INTERLOCK - - .827 TO 1.575  
WITHOUT INTERLOCK - - .827 TO 1.575
- 6. THE BEVELLING OF THE CONTACTS TUBES MAY BE ROUNDED OFF TOWARDS THE INTERNAL CYLINDRICAL SURFACE WITHIN A DISTANCE OF 1-1/2 TIMES THE MAXIMUM DIMENSION.
- 7. NEUTRAL CONTACT WHEN REQUIRED SHALL BE LESS THAN THE PHASE BUT MORE THAN THE GROUND FROM THE FRONTAL FACE.
- 8.  $\perp$  DENOTES EQUIPMENT GROUND CONTACT. TERMINAL SHALL BE IDENTIFIED BY THE WORD "GREEN" AND/OR COLOR GREEN. TERMINAL MAY BE ADDITIONALLY IDENTIFIED BY EARTH SYMBOL ( $\perp$ ).
- 9. N DENOTES GROUNDED LINE CONDUCTOR CONTACT. TERMINAL SHALL BE IDENTIFIED BY THE WORD "WHITE" AND/OR COLOR WHITE. TERMINAL MAY BE ADDITIONALLY IDENTIFIED BY THE LETTER "N".

RATING CONFIGURATIONS  
FRONT VIEW - RECEPTACLE OR CONNECTOR

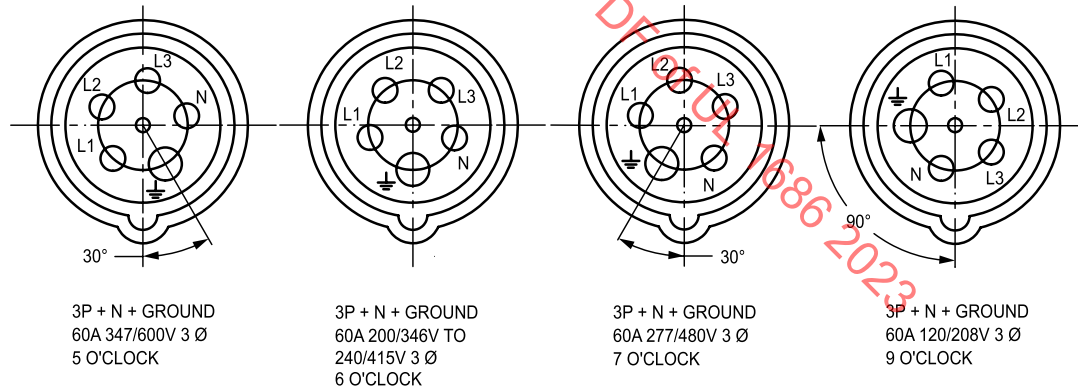
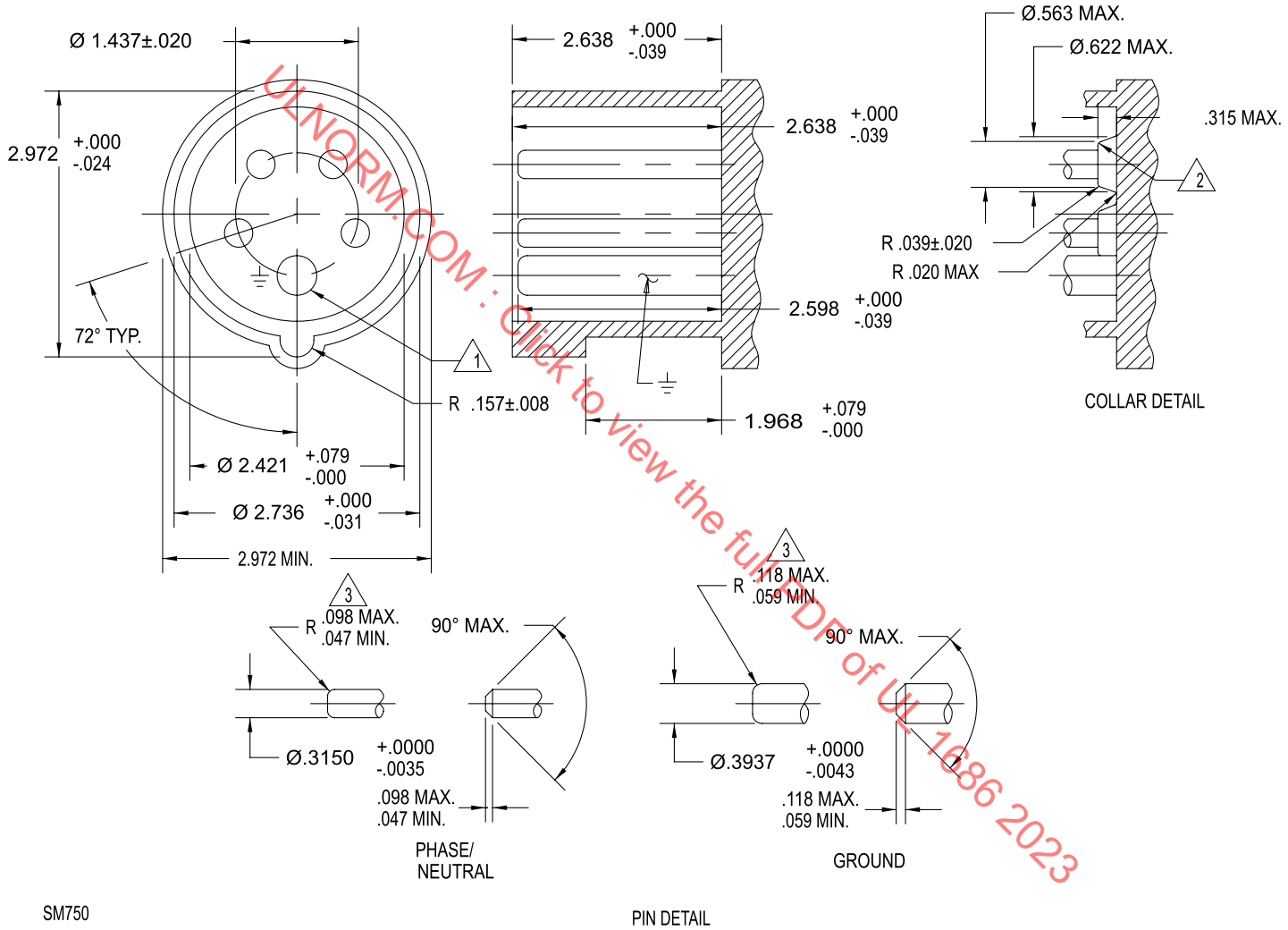

Figure C2.25 (Cont.)

(Continued)



SM750

PIN DETAIL

60 Ampere, 5 Wire Without Pilot  
Plug or Inlet  
Figure C2.26

- 1. MAIN VIEW SHOWN WITH GROUND AT 6 O'CLOCK POSITION FOR REFERENCE ONLY. SEE RATING CONFIGURATION FOR RELEVANT POSITIONS.
- 2. COLLARS REQUIRED FOR DEVICES HAVING RATED OPERATING VOLTAGES EXCEEDING 500 V, OPTIONAL FOR OTHER DEVICES.
- 3. ENDS OF PINS MAY BE ROUNDED OFF TOWARDS THE EXTERNAL CYLINDRICAL SURFACE WITHIN A DISTANCE OF 1-1/2 TIMES OF THE MAXIMUM DIMENSION.
- 4.  $\perp$  DENOTES EQUIPMENT GROUND CONTACT. TERMINAL SHALL BE IDENTIFIED BY THE WORD "GREEN" AND/OR COLOR GREEN. TERMINAL MAY BE ADDITIONALLY IDENTIFIED BY EARTH SYMBOL ( $\perp$ ).
- 5. N DENOTES GROUNDED LINE CONDUCTOR CONTACT. TERMINAL SHALL BE IDENTIFIED BY THE WORD "WHITE" AND/OR COLOR WHITE. TERMINAL MAY BE ADDITIONALLY IDENTIFIED BY THE LETTER "N".

RATING CONFIGURATIONS  
FRONT VIEW - PLUG OR INLET

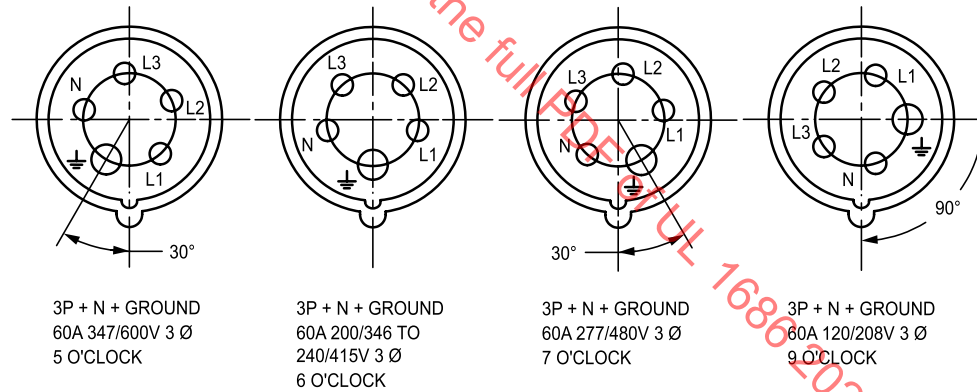

Figure C2.26 (Cont.)

su1366