



# UL 1637

## STANDARD FOR SAFETY

### Home Health Care Signaling Equipment

[ULNORM.COM](https://www.ulnorm.com) : Click to view the full PDF of UL 1637 2022

[ULNORM.COM](https://www.ulnorm.com) : Click to view the full PDF of UL 1637 2022

UL Standard for Safety for Home Health Care Signaling Equipment, UL 1637

Fifth Edition, Dated September 21, 2017

### **Summary of Topics**

***This revision of ANSI/UL 1637 dated July 21, 2022 is being issued to update the title page to reflect the most recent designation as a Reaffirmed American National Standard (ANS). No technical changes have been made.***

Text that has been changed in any manner or impacted by UL's electronic publishing system is marked with a vertical line in the margin.

The requirements are substantially in accordance with Proposal(s) on this subject dated April 22, 2022.

All rights reserved. No part of this publication may be reproduced, stored in a retrieval system, or transmitted in any form by any means, electronic, mechanical photocopying, recording, or otherwise without prior permission of UL.

UL provides this Standard "as is" without warranty of any kind, either expressed or implied, including but not limited to, the implied warranties of merchantability or fitness for any purpose.

In no event will UL be liable for any special, incidental, consequential, indirect or similar damages, including loss of profits, lost savings, loss of data, or any other damages arising out of the use of or the inability to use this Standard, even if UL or an authorized UL representative has been advised of the possibility of such damage. In no event shall UL's liability for any damage ever exceed the price paid for this Standard, regardless of the form of the claim.

Users of the electronic versions of UL's Standards for Safety agree to defend, indemnify, and hold UL harmless from and against any loss, expense, liability, damage, claim, or judgment (including reasonable attorney's fees) resulting from any error or deviation introduced while purchaser is storing an electronic Standard on the purchaser's computer system.

No Text on This Page

[ULNORM.COM](https://ulnorm.com) : Click to view the full PDF of UL 1637 2022

**SEPTEMBER 21, 2017**  
(Title Page Reprinted: July 21, 2022)



**ANSI/UL 1637-2017 (R2022)**

1

**UL 1637**

**Standard for Home Health Care Signaling Equipment**

First Edition – May, 1989  
Second Edition – November, 1993  
Third Edition – October, 1998  
Fourth Edition – December, 2006

**Fifth Edition**

**September 21, 2017**

This ANSI/UL Standard for Safety consists of the Fifth Edition including revisions through July 21, 2022.

The most recent designation of ANSI/UL 1637 as a Reaffirmed American National Standard (ANS) occurred on July 21, 2022. ANSI approval for a standard does not include the Cover Page, Transmittal Pages, and Title Page.

Comments or proposals for revisions on any part of the Standard may be submitted to UL at any time. Proposals should be submitted via a Proposal Request in UL's On-Line Collaborative Standards Development System (CSDS) at <https://csds.ul.com>.

UL's Standards for Safety are copyrighted by UL. Neither a printed nor electronic copy of a Standard should be altered in any way. All of UL's Standards and all copyrights, ownerships, and rights regarding those Standards shall remain the sole and exclusive property of UL.

**COPYRIGHT © 2022 UNDERWRITERS LABORATORIES INC.**

No Text on This Page

[ULNORM.COM](https://ULNORM.COM) : Click to view the full PDF of UL 1637 2022

## CONTENTS

### INTRODUCTION

1	Scope .....	9
2	Components .....	9
3	Units of measurement .....	10
4	Undated references .....	10
5	Glossary .....	10
6	Installation and Operating Instructions .....	11

### CONSTRUCTION

#### ASSEMBLY

7	General .....	13
	7.1 General .....	13
	7.2 Adhesives used to secure conductive parts .....	13
	7.3 Accessibility of uninsulated live parts .....	13
	7.4 Protection of service personnel .....	16
8	Enclosures .....	16
	8.1 General .....	16
	8.2 Cast metal .....	16
	8.3 Sheet metal .....	17
	8.4 Nonmetallic .....	19
	8.5 Doors and covers .....	20
	8.6 Enclosure openings .....	20
	8.7 Screens and expanded metal .....	25
	8.8 Enclosure mounting .....	25
	8.9 Battery compartment (unsealed batteries) .....	25
9	Corrosion Protection .....	26

#### FIELD WIRING

10	Power Supply .....	26
	10.1 General .....	26
	10.2 Field wiring compartment .....	26
	10.3 Terminals (general application) .....	27
	10.4 Terminals (qualified application) .....	27
	10.5 Leads .....	28
	10.6 Cord connected equipment .....	29
	10.7 Permanently connected equipment .....	29
	10.8 Grounding .....	30
11	Polarity Identification .....	31

#### INTERNAL WIRING

12	General .....	31
13	Wiring Methods .....	32
14	Separation of Circuits .....	32
15	Bonding for Grounding .....	33
16	Secondary (Standby) Power Supply .....	35

### COMPONENTS

17	General .....	35
	17.1 Mounting of components .....	35
	17.2 Current-carrying parts .....	36
	17.3 Insulating materials .....	36
	17.4 Fuseholders .....	37
	17.5 Operating mechanisms .....	37
18	Bushings .....	37
19	Transformers, Coils, and Relays .....	38
20	Switches .....	38
21	Overcurrent Protection .....	38
22	Printed Wiring Boards .....	38
23	Capacitors .....	39
24	Semiconductors .....	39
25	Storage Batteries .....	39

## SPACINGS

26	General .....	39
27	Components .....	41

## COMBINATION SYSTEMS

28	General .....	41
	28.1 General .....	41
	28.2 Carbon monoxide signaling systems .....	41

## FCC VERIFICATION

29	General .....	47
----	---------------	----

## PERFORMANCE

### ALL UNITS

30	General .....	47
	30.1 Test units and data .....	47
	30.2 Test voltages .....	47
31	Normal Operation Test .....	48
32	Electrical Supervision Test .....	49
33	Power Supply Supervision Test .....	51
	33.1 Battery powered units .....	51
	33.2 Residential control unit .....	52
	33.3 Central station receiving units .....	52
34	Electrical Measurements Test .....	53
	34.1 Input circuit .....	53
	34.2 Output circuit .....	53
	34.3 Battery circuit .....	53
	34.4 Circuits connected to specific equipment .....	53
35	Volt-Ampere Capacity Test, Low-Voltage Power-Limited Circuits .....	54
36	Undervoltage Operation Test .....	55
37	Overvoltage Operation Test .....	55
38	Jarring Test .....	56
39	Component Temperature Test .....	56
40	Charging Current Test .....	61
41	Battery Charger Tests .....	61

42	Variable Ambient Temperature Test .....	61
43	Humidity Test .....	61
44	Leakage Current Test .....	61
45	Overload Test.....	63
46	Overload Test – Separately Energized Units .....	63
47	Endurance Test.....	63
48	Electrical Transient Tests .....	64
	48.1 General.....	64
	48.2 Externally induced high-voltage (ring wave surge voltage) transients .....	64
	48.3 Internally induced transients .....	65
	48.4 Input/output (low-voltage) field-wiring transients .....	65
49	Dielectric Voltage-Withstand Test .....	72
50	Abnormal Operation Test .....	73
	50.1 General.....	73
	50.2 Variable autotransformer .....	73
	50.3 Overvoltage .....	74
51	Strain Relief Test.....	74
	51.1 Flexible cord.....	74
	51.2 Plug restraining .....	74
	51.3 Field-wiring leads.....	74
52	Drop Test.....	74
53	Mechanical Strength Tests for Enclosures .....	74
54	Polymeric Materials Tests .....	75
	54.1 General.....	75
	54.2 Temperature test .....	75
	54.3 Flame test.....	75
55	Special Terminal Assemblies Test.....	76
	55.1 General.....	76
	55.2 Disconnection and reconnection .....	76
	55.3 Mechanical secureness.....	77
	55.4 Flexing test .....	77
	55.5 Millivolt drop test.....	77
	55.6 Temperature test .....	77
56	Ignition Test Through Bottom-Panel Openings .....	77

## SIGNAL INITIATING UNITS

57	General .....	78
58	Vibration Test.....	78
59	Static Discharge Test.....	79
60	Stability Test .....	79
61	Battery Replacement Test.....	79
62	Polarity Reversal Test.....	80
63	Sensitivity and Range Tests .....	80
64	Photoelectric.....	80
	64.1 Foreign light .....	80
	64.2 Operating speed.....	80
	64.3 Beam cutoff.....	80
	64.4 Range.....	80

## MOVEMENT DETECTORS

65	Microwave .....	81
	65.1 General.....	81
	65.2 Sensitivity .....	81

	65.3 Range.....	81
	65.4 Maximum power density.....	81
66	Sonic and Ultrasonic.....	82
	66.1 General.....	82
	66.2 Sensitivity .....	82
	66.3 Range.....	82
67	Passive Infrared .....	82
	67.1 General.....	82
	67.2 Sensitivity .....	82
	67.3 Stability.....	83
	67.4 Range.....	83
68	Multiplex Systems .....	83
	68.1 General.....	83
	68.2 Operation.....	83
	68.3 Private radio facilities .....	84
69	Digital Communicator Units.....	85
70	Program-Controlled Units and Systems.....	85
	70.1 General.....	85
	70.2 Program access and control .....	85

#### SHORT RANGE RADIO FREQUENCY DEVICES

71	General .....	86
72	Reference Level Determination .....	86
	72.1 Method 1.....	86
	72.2 Method 2.....	88
	72.3 Method 3.....	90
73	Interference Immunity .....	91
74	Frequency Selectivity .....	91
75	Time to Report Alarm.....	92
76	Inoperative Transmitter Reporting.....	92
77	Clash.....	92
78	Error (Falsing) Rate .....	93
79	Throughput Rate .....	94
80	Maximum Duration of Transmission .....	95
81	Battery Status Indication .....	95
82	Transmitter Stability Tests .....	95
83	Transmitter Accelerated Aging Test.....	96
84	Installation Instructions and User Manual .....	96

#### MANUFACTURING AND PRODUCTION LINE TESTS

85	Production-Line Dielectric Voltage-Withstand Test .....	97
86	Production-Line Grounding Continuity Test.....	97

#### MARKING

87	General .....	98
----	---------------	----

#### SUPPLEMENT SA – INSTRUCTIONS FOR CALCULATING ATTENUATION PARAMETERS AND OPEN AREA TEST DISTANCE ( $D_{EOAT}$ )

SA1	Instructions for Determining L1, L2, L3, and L4 Values.....	101
SA2	Determining $L_w$ .....	101
SA3	Determining $L_f$ .....	101

SA4 Determining  $L_b$  ..... 101  
SA5 Determining  $D_{EOAT}$  ..... 101  
SA6 Example Calculation ..... 101  
SA6.1 Use a frequency of 1 GHz, calculate  $D_{EOAT}$  (equivalent open area test distance). .... 101

**APPENDIX A**

Standards for Components ..... 104

ULNORM.COM : Click to view the full PDF of UL 1637 2022

No Text on This Page

[ULNORM.COM](https://www.ulnorm.com) : Click to view the full PDF of UL 1637 2022

## INTRODUCTION

### 1 Scope

1.1 These requirements cover the individual units that comprise a home health care system intended for use in ordinary indoor residential locations.

1.2 These requirements also cover a complete home health care system in which a signal initiating device (both routine monitoring and medical emergency signals) may be connected directly or indirectly to receiving equipment at a residence or to continuously monitored receiving equipment at a central supervising station. The system is arranged so that a predetermined change in the status of the signal initiating circuits or devices automatically causes transmission of a signal over a communication channel to receiving equipment at a residence, to a central supervising station, or to a private telephone number.

1.3 The components of the home health care system may include signal initiating devices, control units, transmitters, and digital communicators, all located at the residence, and the receiving, processing, and displaying equipment located at the central supervising station.

1.4 All field wiring extending to signal initiating units located at the residence is intended to be energized from power limited circuits as defined in [5.3](#) (c).

1.5 The units covered by these requirements are intended to be installed in accordance with the requirements of:

- a) The National Electrical Code, NFPA 70;
- b) Other applicable installation codes; and
- c) The local inspection authority having jurisdiction.

1.6 Where a unit employs residential fire alarm functions, it shall comply with the Standard for Household Fire Warning System Units, UL 985. Where a unit employs household burglar alarm functions, it shall comply with the Standard for Household Burglar-Alarm System Units, UL 1023. A unit utilizing non-fire and/or non-carbon monoxide emergency and/or non-emergency signaling functions shall meet the requirements of the Standard for General Purpose Signaling Devices and Systems, UL 2017.

### 2 Components

2.1 Except as indicated in [2.2](#), a component of a unit covered by this standard shall comply with the requirements for that component. See Appendix [A](#) for a list of standards covering components generally used in the units covered by this standard.

2.2 A component need not comply with a specific requirement that:

- a) Involves a feature or characteristic not needed in the application of the component in the unit covered by this standard or
- b) Is superseded by a requirement in this standard.

2.3 A component shall be used in accordance with its recognized rating established for the intended conditions of use.

2.4 Specific components are recognized as being incomplete in construction features or restricted in performance capabilities. Such components are intended for use only under limited conditions, such as

certain temperatures not exceeding specified limits and shall be used only under those specific conditions for which they have been recognized.

2.5 If a digital alarm communicator transmitter is used to transmit signals to a remote location and is to be included as a component of the system, it shall comply with the applicable requirements in the Standard for Digital Alarm Communicator System Units, UL 1635. Otherwise the user must be notified that the off-premises transmission method has not been so investigated.

### 3 Units of measurement

3.1 When a value for measurement is followed by a value in other units in parentheses, the first stated value is the requirement.

3.2 Unless otherwise indicated, all voltage and current values mentioned in this standard are root-mean-square (rms).

### 4 Undated references

4.1 Any undated reference to a code or standard appearing in the requirements of this standard shall be interpreted as referring to the latest edition of that code or standard.

### 5 Glossary

5.1 For the purpose of this standard the following definitions apply.

5.2 CENTRAL STATION RECEIVING UNIT – Equipment located at a central station that receives and displays the information to the operator for action.

5.3 CIRCUITS, ELECTRICAL –

- a) High-Voltage – A circuit involving a potential of not more than 600 volts and having circuit characteristics in excess of those of a low-voltage power limited circuit.
- b) Low-Voltage – A circuit involving a potential of not more than 30 volts AC rms, 42.4 volts AC peak or DC.
- c) Power Limited – A circuit in which the output is limited to 100 volt-amperes, at a maximum of 30 volts AC, 42.4 volts DC. The power limitation is typically provided by a transformer, a fixed impedance, a noninterchangeable fuse, a nonadjustable manual reset circuit protective device, or a regulating network.

5.4 CORD-CONNECTED UNIT – A unit intended for connection to the power source by means of a supply cord.

5.5 MEDICAL EMERGENCY SIGNAL – A signal from an initiating device that requires specific action from the receiver.

5.6 MONITOR SIGNAL – A signal from a monitor-type initiating device that requires no immediate action.

5.7 NORMAL STANDBY CONDITION – The ready-to-operate condition that exists prior to any type of signaling condition.

5.8 PERSONAL CALL UNIT – A device from which the resident may place a call to a central station receiving unit, other receiving unit, or to a private telephone number. This unit may be fixed or portable (carried by the resident). Operation of the unit transmits a medical emergency signal.

5.9 PROGRAM – A set of instructions that is carried out in a sequential and repetitive manner and that determines the system output signal resulting from system input signal.

5.10 RADIO FREQUENCY – Electromagnetic radiation 10 kilohertz or higher.

5.11 RESIDENTIAL CONTROL UNIT – A device that receives input signals from the monitor and personal call units and transmits the information to a central station receiving unit or to a private telephone number. A residential control unit may or may not process the signal.

5.12 SIGNAL INITIATING UNIT – A manually or automatically operated device in which intended operation results in a signal indication to the residential control unit. The signals may be "Medical Emergency," "Monitor," or "Trouble."

5.13 SIGNALING UNIT – All devices and appliances covered by this standard.

5.14 STORED – The action provided by a memory device used for retaining information, instruction, status, and the like. It may be permanent or volatile.

5.15 SUPERVISION – Monitoring of a critical circuit for a fault condition, such as an open, ground, short circuit fault, or loss of transmission capability.

5.16 TROUBLE SIGNAL – A signal that indicates the presence of a fault condition that may impair system operation.

5.17 UNOCCUPIED PERIOD – Period during which the residence is vacant.

5.18 TRAINED INSTALLER – An individual knowledgeable in the product operation and received instruction on installing the product.

## 6 Installation and Operating Instructions

6.1 A copy or draft of the installation and operating instructions, related schematic wiring diagrams, and installation drawings intended to accompany the equipment are to be furnished with the sample submitted for investigation and are to be used as a guide in the examination and test of the equipment.

6.2 The instructions and drawings shall include at least the following:

- a) Typical installation drawing layouts and complete representative installation wiring diagram(s) for the signaling unit(s) indicating recommended locations and wiring methods.
- b) A concise description of the operation, testing, and maintenance procedures for the signaling unit(s), and recommended testing frequency.
- c) Replacement parts, such as lamps or batteries, identified in the instructions by a part number, manufacturer's model number, or the equivalent.
- d) A description of the conditions which might be expected to result in unintended signals or impaired operation of the signaling unit(s).

e) A description of any features provided to reduce the risk of fire or electric shock and a warning against bypassing such features.

f) Identification of units that are factory serviceable only. A statement shall be provided indicating that these units should be returned to the manufacturer for service. The manufacturer's name and address shall also be included.

6.3 An installation wiring diagram(s) shall be provided with each signaling unit indicating the field connections to be made. The diagram(s) shall be attached to the residence and receiving units or, if separate, shall be referenced in the marking attached to these units with the diagram number and issue number or date, or both.

6.4 An installation wiring diagram shall show a pictorial view or equivalent of the installation terminals or leads to which field connections are made as they would appear when viewed from the front or normal connecting position. The terminal numbers on the unit shall agree with the numbers on the diagram. An unattached diagram shall be marked with the name or trademark of the manufacturer and an identification number or equivalent.

6.5 If low-voltage, power limited circuit terminal configurations are used that require a special tool for connection, the tool shall be referenced in the instructions.

6.6 The instructions shall be incorporated on the inside of the product, on a separate sheet, or as part of a manual, unless meeting [6.7](#) or [6.8](#). If not included directly on the signaling unit product, the instructions or manual shall be referenced in the marking information on the product. See Marking, General, Section [87](#).

6.7 For products intended only to be installed by a trained installer the installation instructions containing the information required by [6.1](#) – [6.6](#) is not prohibited from being made available by one or more of the following means:

- a) Electronic instructions within the basic product software;
- b) Electronic media such as website, CD-ROM, DVD, etc.; or
- c) When the instructions are included as described in (a) or (b), the instructions shall be referenced in the product marking by:
  - 1) Name or trademark of manufacturer,
  - 2) Drawing number, <URL address> (This may be a root or home page and not a specific location), and/or equivalent identification, and
  - 3) Issue date, revision level, and/or release date, or equivalent information such as date of manufacture or firmware level, which correlates the applicable digital manual revision to the product's current hardware/software. (For example, the product is marked with the date of manufacture or firmware level and the digital manual references the date or firmware range to which the manual is applicable).

6.8 Installation Instructions for products that require an Internet connection for initial configuration containing the information required by [6.1](#) – [6.6](#) is not prohibited from being made available by the means provided in [6.7](#) given the requirements of one of the following are met:

- a) Where hardcopy installation instructions are not provided, the product annunciates an audible trouble signal when the product is energized until the product; or

b) A constant visual signal visible to the user after the product is installed is permitted to be used in lieu of the audible trouble signal required by [82.1](#) Exception No. 2 (1) when the following information is provided in hardcopy with the product:

- 1) Statement the device must be installed and configured before it is to be used,
- 2) Statement the full manual is to be obtained before installation is started and the website or online location where it is available, and
- 3) Description of the visual indication given and its meaning.

## CONSTRUCTION

### ASSEMBLY

#### 7 General

##### 7.1 General

7.1.1 Products that currently meet all the requirements of the Standard for Information Technology Equipment - Safety - Part 1: General Requirements, UL 60950-1 or the Standard for Audio, Video, and Similar Electronic Apparatus-Safety Requirements, UL 60065 need only be evaluated to the following construction requirements: [10.6.1](#), [10.6.6](#), [10.6.7](#), and the following sections: [8.5](#), Doors and covers, [8.8](#), Enclosure mounting, [10.5](#), Leads, [16](#), Secondary (Standby) Power Supply, [21](#), Overcurrent Protection, [23](#), Capacitors, [24](#), Semiconductors, [25](#), Storage Batteries, and [28](#), General.

##### 7.2 Adhesives used to secure conductive parts

7.2.1 An adhesive that is relied upon to reduce a risk of fire, electric shock, or injury to persons shall comply with the requirements for adhesives in the Standard for Polymeric Materials – Use in Electrical Equipment Evaluations, UL 746C.

7.2.2 The requirement in [7.1.1](#) applies to an adhesive used to secure a conductive part, including a nameplate, that may, if loosened or dislodged:

- a) Energize an accessible dead metal part,
- b) Make a live part accessible,
- c) Reduce spacings below the minimum required values, or
- d) Short-circuit live parts.

7.2.3 Whether the conditions specified in [7.2.2](#) (a) – (d) can occur is to be considered with respect to both:

- a) A part inside the device and
- b) A part on the outside of the device that may affect equipment in which the device is to be installed.

##### 7.3 Accessibility of uninsulated live parts

7.3.1 An opening shall not permit entrance of a 1/2-inch (12.7-mm) diameter rod and shall be sized and arranged so that a nonmetallic probe, as illustrated in [Figure 7.1](#), cannot be made to contact any

uninsulated live electrical part (other than a low-voltage part) when inserted through the opening in a straight or articulated position.

[ULNORM.COM](https://www.ulnorm.com) : Click to view the full PDF of UL 1637 2022

Figure 7.1  
Articulate probe with web stop

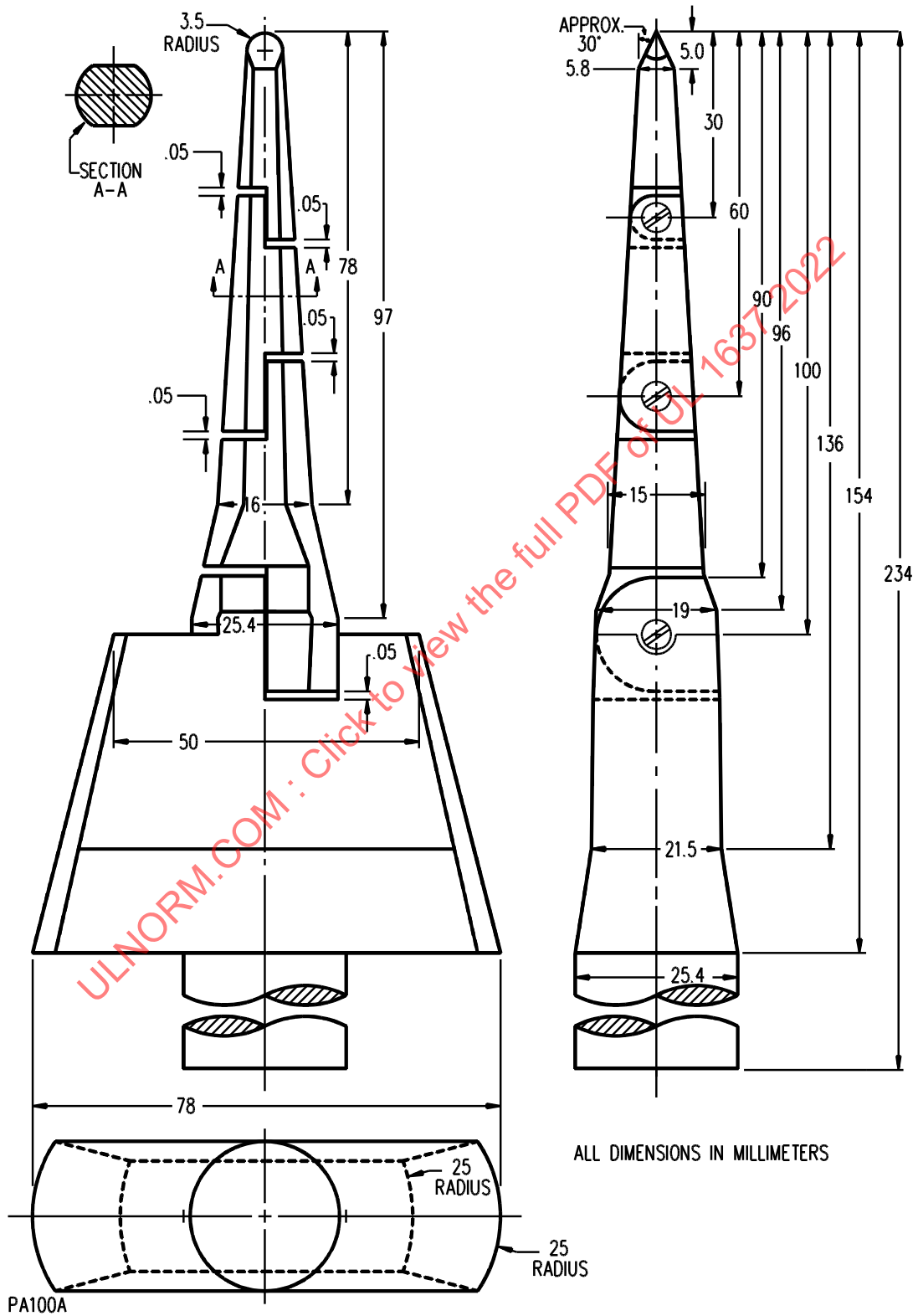

The UL articulate probe without the web stop may be used for openings having a minor dimension less than 3/4 inch (19.1 mm).

## 7.4 Protection of service personnel

7.4.1 An uninsulated live part of a high-voltage circuit within the enclosure shall be located, guarded, or enclosed so as to reduce the risk of accidental contact by persons performing service functions that may be performed while the equipment is energized.

7.4.2 During the examination of a signaling unit in connection with the requirements in [7.3.1](#), a part of the outer enclosure that may be removed without the use of tools, or part of the outer enclosure that may be removed by the user to allow access for making intended operating adjustments, is to be disregarded. It will not be assumed that the part in question affords protection against electric shock.

7.4.3 An electrical component requiring examination, replacement, adjustment, servicing, or maintenance while the signaling unit is energized shall be located and mounted with respect to other components and with respect to grounded metal so that it is accessible for such service without subjecting service personnel to the risk of electric shock from adjacent uninsulated high-voltage live parts.

7.4.4 The following are not considered to be uninsulated live parts:

- a) Coils of relays and solenoids, and transformer windings, if the coils and windings are provided with insulating overwraps rated for the potentials encountered;
- b) Terminals and splices having insulation rated for the potential encountered; and
- c) Insulated wire.

7.4.5 If the linear distance from a component requiring servicing to all uninsulated current-carrying parts in excess of 30 volts rms, 42.4 volts peak, 60 volts DC, is less than 6 inches (152 mm), protection shall be provided by insulating tape, barriers, or the equivalent.

*Exception: Compliance with this requirement may be achieved by use of:*

- a) *An interlock provided on the cover that de-energizes all live parts in the enclosure when the cover is removed or*
- b) *The following or equivalent permanent and prominent marking provided on the cover front: "CAUTION – Risk of Electrical Shock, De-Energize Unit Prior To Servicing." This marking may be located on a rear panel or at the point of entry if the equipment is factory serviceable only.*

## 8 Enclosures

### 8.1 General

8.1.1 The frame and enclosure of a signaling unit shall have the strength and rigidity to resist total or partial collapse and the subsequent reduction of spacings, or loosening or displacement of parts. See the Mechanical Strength Tests for Enclosures, Section [53](#).

### 8.2 Cast metal

8.2.1 The thickness of a cast metal enclosure shall be as specified in [Table 8.1](#).

*Exception: Cast metal of lesser thickness may be employed if, consideration being given to the shape, size, and function of the enclosure, it provides equivalent mechanical strength to metal of the thickness specified in the table. See the Mechanical Strength Tests for Enclosures, Section [53](#).*

**Table 8.1  
Cast-metal electrical enclosures**

Use, or dimensions of area involved <sup>a</sup>	Minimum thickness			
	Die-cast metal,		Cast metal of other than the die-cast type,	
	inch	(mm)	inch	(mm)
Area of 24 square inches (115 cm <sup>2</sup> ) or less and having no dimensions greater than 6 inches (152 mm)	1/16	(1.6)	1/8	(3.2)
Area greater than 24 square inches (155 cm <sup>2</sup> ) or having any dimension greater than 6 inches (152 mm)	3/32	(2.4)	1/8	(3.2)
At a threaded conduit hole	1/4	(6.4)	1/4	(6.4)
At an unthreaded conduit hole	1/8	(3.2)	1/8	(3.2)

<sup>a</sup> The area limitation for metal 1/16 inch (1.6 mm) in thickness may be obtained by the provision of reinforcing ribs subdividing a larger area.

**8.3 Sheet metal**

8.3.1 The thickness of sheet metal for an enclosure shall be not less than that indicated in [Table 8.2](#) or [Table 8.3](#), whichever applies.

*Exception: Sheet metal of lesser thickness may be employed if, consideration being given to the shape, size, and function of the enclosure, it provides equivalent mechanical strength to metal of the thickness specified in the table. See the Mechanical Strength Tests for Enclosures, Section 53.*

**Table 8.2  
Minimum thickness of sheet metal for electrical enclosures – carbon steel or stainless steel**

Without supporting frame <sup>a</sup>		With supporting frame or equivalent reinforcing <sup>a</sup>		Minimum thickness, Uncoated,		Minimum thickness, Metal coated,			
Maximum width, <sup>b</sup>	Maximum length, <sup>b</sup>	Maximum width, <sup>b</sup>	Maximum length, <sup>b</sup>	inch	(mm)	inch	(mm)		
inches	(cm)	inches	(cm)	[MSG]		[GSG]			
4.0	(10.2)	Not limited	6.25	(15.9)	Not limited	0.020	(0.51)	0.023	(0.58)
4.75	(12.1)	5.75	(14.6)	6.75	(17.1)	8.25	(21.0)	[24]	[24]
6.0	(15.2)	Not limited	9.5	(24.1)	Not limited	0.026	(0.66)	0.029	(0.74)
7.0	(17.8)	8.75	(22.2)	10.0	(25.4)	12.5	(31.8)	[22]	[22]
8.0	(20.3)	Not limited	12.0	(30.5)	Not limited	0.032	(0.81)	0.034	(0.86)
9.0	(22.9)	11.5	(29.2)	13.0	(33.0)	16.0	(40.6)	[20]	[20]
12.5	(31.8)	Not limited	19.5	(49.5)	Not limited	0.042	(1.07)	0.045	(1.14)
14.0	(35.6)	18.0	(45.7)	21.0	(53.3)	25.0	(63.5)	[18]	[18]
18.0	(45.7)	Not limited	27.0	(68.6)	Not limited	0.053	(1.35)	0.056	(1.42)
20.0	(50.8)	25.0	(63.5)	29.0	(73.7)	36.0	(91.4)	[16]	[16]
22.0	(55.9)	Not limited	33.0	(83.8)	Not limited	0.060	(1.52)	0.063	(1.60)
25.0	(63.5)	31.0	(78.7)	35.0	(88.9)	43.0	(109.2)	[15]	[15]
25.0	(63.5)	Not limited	39.0	(99.1)	Not limited	0.067	(1.70)	0.070	(1.78)
29.0	(73.7)	36.0	(91.4)	41.0	(104.1)	51.0	(129.5)	[14]	[14]

Table 8.2 Continued on Next Page