



UL 153

STANDARD FOR SAFETY

Portable Electric Luminaires

ULNORM.COM : Click to view the full PDF of UL 153 2025

[ULNORM.COM](https://ulnorm.com) : Click to view the full PDF of UL 153 2025

UL Standard for Safety for Portable Electric Luminaires, UL 153

Thirteenth Edition, Dated March 3, 2014

Summary of Topics

These revisions to ANSI/UL 153 dated February 24, 2025 includes the following changes in requirements:

- **QR code as an Alternative to Website Address (URL); [198.1.3](#)**
- **Marking Adjusted to Remove the Word “max”; [199.1](#)**
- **LED Portable Luminaires with Smaller than 18 AWG Power Supply Cord; [17.3](#), [17.4](#), [27.1.1](#), [Table 27.1](#), [30.3](#), [Table 31.1](#), [31.2](#), [31.5](#), [31.5A](#), [31.7](#), [Table 35.1](#), [Sections 69A – 69C](#), and [Table 75.1](#)**
- **Photobiological Safety Assessment for battery-operated portable luminaires with visible light spectrum light source – Supplement SA, [SA5.6.1](#)**
- **Button Batteries or Coin Cell Batteries; [47.4.1](#) and [Appendix A](#)**

Text that has been changed in any manner or impacted by ULSE's electronic publishing system is marked with a vertical line in the margin.

The new and revised requirements are substantially in accordance with Proposal(s) on this subject dated September 13, 2024.

All rights reserved. No part of this publication may be reproduced, stored in a retrieval system, or transmitted in any form by any means, electronic, mechanical photocopying, recording, or otherwise without prior permission of ULSE Inc. (ULSE).

ULSE provides this Standard "as is" without warranty of any kind, either expressed or implied, including but not limited to, the implied warranties of merchantability or fitness for any purpose.

In no event will ULSE be liable for any special, incidental, consequential, indirect or similar damages, including loss of profits, lost savings, loss of data, or any other damages arising out of the use of or the inability to use this Standard, even if ULSE or an authorized ULSE representative has been advised of the possibility of such damage. In no event shall ULSE's liability for any damage ever exceed the price paid for this Standard, regardless of the form of the claim.

Users of the electronic versions of UL's Standards for Safety agree to defend, indemnify, and hold ULSE harmless from and against any loss, expense, liability, damage, claim, or judgment (including reasonable attorney's fees) resulting from any error or deviation introduced while purchaser is storing an electronic Standard on the purchaser's computer system.

No Text on This Page

ULNORM.COM : Click to view the full PDF of UL 153 2025

MARCH 3, 2014

(Title Page Reprinted: February 24, 2025)

1

UL 153

Standard for Portable Electric Luminaires

The first through the eleventh editions were titled Portable Electric Lamps.

First Edition – October, 1952
Second Edition – August, 1955
Third Edition – March, 1958
Fourth Edition – September, 1970
Fifth Edition – October, 1976
Sixth Edition – August, 1978
Seventh Edition – April, 1981
Eighth Edition – April, 1982
Ninth Edition – November, 1988
Tenth Edition – May, 1994
Eleventh Edition – May, 1995
Twelfth Edition – March, 2002

Thirteenth Edition

March 3, 2014

This ANSI/UL Standard for Safety consists of the Thirteenth Edition including revisions through February 24, 2025.

The most recent designation of ANSI/UL 153 as an American National Standard (ANSI) occurred on February 24, 2025. ANSI approval for a standard does not include the Cover Page, Transmittal Pages, and Title Page.

Comments or proposals for revisions on any part of the Standard may be submitted to ULSE at any time. Proposals should be submitted via a Proposal Request in the Collaborative Standards Development System (CSDS) at <https://csds.ul.com>.

Our Standards for Safety are copyrighted by ULSE Inc. Neither a printed nor electronic copy of a Standard should be altered in any way. All of our Standards and all copyrights, ownerships, and rights regarding those Standards shall remain the sole and exclusive property of ULSE Inc.

© 2025 ULSE Inc. All rights reserved.

No Text on This Page

ULNORM.COM : Click to view the full PDF of UL 153 2025

CONTENTS

INTRODUCTION

1	Scope	19
2	Glossary	20
3	Organization and Application	25
4	Components	26
5	Units of Measurement	26
6	Undated References	26

CONSTRUCTION

MECHANICAL CONSTRUCTION – GENERAL

7	General	27
8	Assembly and Packaging	27
9	Enclosures	28
10	Metal Thickness for Enclosures	29
11	Corrosion Protection	31
12	Polymeric Enclosures	31
13	Decorative Parts	32
14	Enclosure Openings	32
15	Wireways and Tubing	34
16	Shade Construction	34
17	Strain Relief	35
18	Portable Luminaires Having Play Value	35
19	Resistance to Liquid Damage	36
20	Portable Luminaire Containing Hazardous Substance	36
20A	Plant Luminaires	36
	20A.1 General	36
	20A.2 Resistance to moisture	37
	20A.3 Resistance to chemicals	37
	20A.4 Lamp replacement	37

ELECTRICAL CONSTRUCTION – GENERAL

21	General	37
22	Assembly and Packaging	37
23	Accessibility of Live Parts	38
24	Electrical Spacings	40
25	Insulating Materials	41
26	Electrical Ratings	42
27	Wiring and Conductors	43
	27.1 Conductor size	43
	27.2 Temperature and voltage rating	43
28	Splices and Connections	46
29	Wiring Attached to Movable or Flexible Parts	47
30	Protection of Wiring	47
31	Power-Supply Cords	48
32	Attachment Plugs	49
33	Interconnected Units	50
34	Alternate Power-Supply Connections	51
35	Polarization and Identification	52

36	Grounding and Bonding	53
37	Electronic Circuits	54
38	Secondary Low Voltage Circuits	54
39	Separation of Secondary Circuit Conductors	55
40	Separation of Communication Circuit Conductors	55
41	Component Mounting	55
42	Lampholders	56
	42.1 General.....	56
	42.2 Incandescent lampholders.....	57
	42.3 Fluorescent lampholders	57
43	Switches and Dimmers	57
44	Receptacles.....	59
45	Transformers	59
46	Motors	60
46A	Overcurrent Protection	60
47	Portable Luminaires with Batteries.....	60

INCANDESCENT UNITS – SUPPLEMENTARY

48	General	61
49	Temperature Test-Exempt Units	62
	49.1 General.....	62
	49.2 Determination of temperature test-exempt status	62
	49.3 Shade designation.....	62
	49.4 Lamp-to-shade spacing.....	65
	49.5 Wire insulation temperature rating.....	69
	49.6 Other shade designs.....	69
50	Incandescent Torchiere.....	69
51	Tests	70
	51.1 Normal temperature test.....	70
	51.2 Incandescent torchiere abnormal operation tests	70
	51.3 Torchiere input test	70
52	Markings.....	71
53	Instructions	71

TUNGSTEN HALOGEN UNITS – SUPPLEMENTARY

54	General	71
55	Construction – Mechanical	71
	55.1 General.....	71
	55.2 Guard	74
	55.3 Guards for torchiere style units	75
	55.4 Lamp containment barrier.....	77
	55.5 Ultraviolet (UV) filter.....	78
	55.6 Flexible or articulated arms.....	79
56	Construction – Electrical	79
	56.1 Switches	79
	56.2 Interlock switch.....	80
	56.3 Automatic temperature-regulating or limiting control	80
	56.4 Tipover switch	80
57	Tests	81
	57.1 Normal temperature test.....	81
	57.2 Tungsten-halogen lamp adjacent surfaces and overlamping abnormal operation tests ..	81
	57.3 Tungsten-halogen torchiere abnormal operation tests.....	81
	57.4 Guard, lamp containment barrier & UV filter security tests.....	82

57.5 Polymeric lamp containment test..... 82
 57.6 Interlock switch tests..... 82
 57.7 Torchiere input test 82
 58 Marking 82
 59 Instructions 82

FLUORESCENT UNITS – SUPPLEMENTARY

60 General 83
 61 Construction – Electrical 83
 61.1 Ballasts..... 83
 61.2 Lampholder..... 83
 61.3 Wire temperature ratings 83
 62 Tests 84
 62.1 Normal temperature test..... 84
 62.2 Abnormal operation shorted starter test..... 84
 63 Temperature Test-Exempt Units 84
 64 Marking 86

HIGH INTENSITY DISCHARGE UNITS – SUPPLEMENTARY

65 General 86
 66 Construction – Mechanical 86
 66.1 Metal halide lamp containment and UV filter..... 86
 67 Construction – Electrical 86
 67.1 Lampholders 86
 67.2 Ballasts..... 86
 67.3 Capacitors 86
 67.4 Nonintegral oil-filled capacitors 87
 68 Tests 88
 68.1 Normal temperature test..... 88
 68.2 Glass impact test..... 89
 68.3 Glass thermal shock/containment test 89
 69 Markings..... 89

LED PORTABLE LUMINAIRES WITH SMALLER THAN 18 AWG POWER SUPPLY CORD – SUPPLEMENTARY

69A General..... 89
 69B Construction – Electrical 90
 69B.1 Electrical ratings..... 90
 69B.2 Power supply cord 90
 69B.3 Wiring and conductors 90
 69C Power Supply Cord Short Circuit Test 90

SURFACE MOUNTED UNITS – SUPPLEMENTARY

70 General 91
 71 Wall Mounted Units 91
 71.1 General..... 91
 71.2 Construction – mechanical 91
 71.3 Construction – electrical 92
 71.4 Instructions 92
 72 Under-Shelf Mounted Units 92
 72.1 General..... 92

72.2	Mounting means	92
72.3	Construction – electrical	92
72.4	Markings	93
73	Appliance Mounted Units	93
73.1	General.....	93
73.2	Instructions	93

CORD AND CHAIN SUSPENDED UNITS – SUPPLEMENTARY

74	General	93
75	Construction – Mechanical	94
75.1	Chains	94
75.2	Support hardware	94
75.3	Maximum weight.....	94
76	Construction – Electrical	95
76.1	Internal wiring protection	95
76.2	Power-supply cord	95
76.3	Lampholders and switches	96
77	Tests	97
77.1	Mounting means test.....	97
77.2	Tests for suspended toys.....	97
78	Markings.....	97
79	Instructions	97

CLAMP-ON MOUNTED UNITS – SUPPLEMENTARY

80	General	97
81	Construction – Mechanical	97
81.1	Clamp.....	97
82	Construction – Electrical	98
82.1	Power-supply cords	98
82.2	Lampholders and switches	98
83	Tests	98
83.1	Mounting means test.....	98

PORTABLE CABINET LIGHTS – SUPPLEMENTARY

84	General	98
85	Construction – Mechanical	98
85.1	Mounting means	98
86	Construction – Electrical	99
86.1	Power-supply cords	99
86.2	Interconnecting cord	99
86.3	Attachment plugs and receptacles	99
86.4	Lampholders	99
86.5	Low voltage portable cabinet lights.....	99
86.6	Portable cabinet light accessories	100
87	Tests	100
87.1	Normal temperature test.....	100
88	Markings.....	100
89	Instructions	100

UNITS FOR USE WITH OFFICE FURNISHINGS – SUPPLEMENTARY

90	General	100
----	---------------	-----

91	Construction – Mechanical	100
92	Construction – Electrical	101
	92.1 Power-supply cords	101
	92.2 Plugs and receptacles	101
	92.3 Interconnecting cord	101
93	Markings.....	101
94	Instructions	102

CONVERTIBLE UNITS – SUPPLEMENTARY

95	General	102
96	Construction – Mechanical	102
	96.1 Swag-to-chandelier conversion kits	102
	96.2 Surface mount conversion kits	102
	96.3 Under-shelf mounted conversion kits.....	102
97	Construction – Electrical	103
	97.1 Grounding	103
	97.2 General.....	103
	97.3 Polarity	103
	97.4 Power – supply cord.....	103
98	Markings.....	103
99	Instructions	103

INTERCHANGEABLE UNITS – SUPPLEMENTARY REQUIREMENTS

100	General	104
101	Construction – Mechanical	104
	101.1 Mounting	104
102	Construction – Electrical	104
	102.1 Power-supply cords	104
	102.2 Polarization	104
	102.3 Adapter	105
103	Markings	105

TRACK-STYLE UNITS – SUPPLEMENTARY

104	General	105
105	Construction – Mechanical	105
	105.1 Track	105
	105.2 Securement of cord and end cap.....	105
	105.3 Mounting means	105
106	Construction – Electrical	106
	106.1 Power-supply cords	106
	106.2 Polarity	106
	106.3 Receptacles	106
107	Tests	106
	107.1 Mechanical means of polarity test	106
	107.2 Track clip securement test	106
108	Markings.....	106
109	Instructions	107

PORTABLE LUMINAIRE KIT – SUPPLEMENTARY

110	General.....	107
111	Construction – Mechanical.....	107

111.1	General	107
111.2	Shade	107
112	Construction – Electrical.....	107
112.1	General	107
112.2	Mounting of components	108
113	Tests.....	108
113.1	Assembly and installation test	108
114	Markings	108
115	Instructions	108

PORTABLE LUMINAIRE SUBASSEMBLIES – SUPPLEMENTARY

116	General.....	108
117	Construction – Electrical.....	108
117.1	General	108
117.2	Power-supply cord	109
117.3	Mounting of components	109
118	Assembly and Installation Test.....	109
119	Markings	109
120	Instructions	109

PORTABLE LUMINAIRE ACCESSORIES – SUPPLEMENTARY

121	General	109
122	Construction	109
123	Markings.....	109
124	Instructions	110

WORK LIGHTS – SUPPLEMENTARY

125	General	110
126	Construction – Mechanical.....	110
126.1	Assembly	110
126.2	Guards.....	110
126.3	Handles	111
126.4	Bases and stands	112
127	Construction – Electrical	112
127.1	Power-supply cords	112
127.2	Grounding type attachment plug	112
127.3	Receptacles	113
127.4	Tipover switches	113
128	Tests	114
128.1	Normal temperature test.....	114
128.2	Abnormal operation tests.....	114
128.3	Stability tests	114
129	Markings.....	114

DAMP LOCATION USE – SUPPLEMENTARY

129A	General	114
129B	Construction	114
129C	Tests	115
129D	Markings	115

WET LOCATION USE – SUPPLEMENTARY

130	General	115
131	Construction – Mechanical	115
	131.1 Enclosure	115
	131.2 Water shields	116
	131.3 Corrosion protection	116
	131.4 Drain openings	116
	131.5 Gaskets	117
	131.6 Mounting stakes	117
132	Construction – Electrical	117
	132.1 Power-supply cords	117
	132.2 Grounding type attachment plug	117
	132.3 Receptacles	118
	132.4 Lampholders	118
	132.5 Switches	118
	132.6 Electrical insulation	118
133	Tests	118
	133.1 Wet location tests	118
134	Markings	118
135	Instructions	118

PORTABLE HAND LIGHTS – SUPPLEMENTARY

136	General	118
137	Construction – Mechanical	119
	137.1 General	119
	137.2 Assembly and packaging	119
	137.3 Lamp guard	119
	137.4 Corrosion protection	120
138	Construction – Electrical	120
	138.1 General	120
	138.2 Assembly	120
	138.3 Wiring and conductors	121
	138.4 Protection of wiring	121
	138.5 Power-supply cords	121
	138.6 Grounding type attachment plug	122
	138.7 Incandescent lampholders	122
	138.8 Switches	122
	138.9 Receptacles	123
139	Supplementary Protection	123
140	Tests	124
	140.1 Normal temperature test	124
	140.2 Abnormal operation tests	124
	140.3 Mechanical tests	124
	140.4 Electrical tests	124
141	Markings	124
142	Instructions	125

PERFORMANCE

GENERAL – NORMAL TEMPERATURE TEST

143	General	125
144	Test Method – General	125
	144.1 Temperature limits	125
	144.2 Test duration	128

144.3	Temperature measurement by thermocouple	128
144.4	Temperature measurement by change-of-resistance	129
144.5	Ambient temperature measurement	129
144.6	Test voltage, current, and wattage	129
144.7	High intensity discharge lamp nominal test conditions	130
144.8	Incandescent test lamps	130
144.9	Tungsten-halogen test lamps	132
144.10	Fluorescent test lamps	132
144.11	High intensity discharge test lamps	132
144.11A	Self-Ballasted LED Lamps	132
144.12	Shade positions and decorative parts	133
144.13	Portable luminaires with secondary batteries	133
145	Specific Test Conditions – Free Standing and Surface Mounted Units	133
145.1	General	133
145.2	Test results	134
146	Specific Test Conditions – Portable Cabinet Lights	134
146.1	Other than pot style	134
146.2	Pot style	136
146.3	Test results	137
147	Specific Test Conditions – Work Lights	137
147.1	General	137
147.2	Test results	137
148	Specific Test Conditions – Portable Hand Lights	137
148.1	General	137
148.2	Test results	138

GENERAL – ABNORMAL OPERATION TESTS

149	Adjustable Position or Multiple Shade Abnormal Operation Test	138
149.1	General	138
149.2	Test method – general	138
149.3	Test method – adjustable or flexible shade position	139
149.4	Test method – multiple shades	139
149.5	Test method – folding position	139
149.6	Test results	139
150	Transformer Short-Circuited Test	140
150.1	General	140
150.2	Test method	140
150.3	Test results	140
151	Component Fault Test	141
151.1	General	141
151.2	Test method	141
151.3	Test results	141
152	Conductor Short Circuit and Abnormal Operation Test	142
152.1	General	142
152.2	Test method – short circuit	142
152.3	Test method – abnormal operation	142
152.4	Test results	142
152A	Exposed Class 2 Conductor Abnormal Operation Test	142

GENERAL – MECHANICAL TESTS

153	Stability Test	143
153.1	General	143
153.2	Test method – general	143
153.3	Test method – units with flexible or articulated arm	143

153.4	Test method – units having provisions for loading	144
153.5	Test results	144
154	Strain Relief Test	144
154.1	General	144
154.2	Test method	144
154.3	Test results	145
155	Drop Test	145
155.1	General	145
155.2	Test method	145
155.3	Test results	145
156	Security of Screws Test	146
156.1	General	146
156.2	Test method	146
156.3	Test results	146
157	Power-Supply Cord Twist Test	146
157.1	General	146
157.2	Method	146
157.3	Results	147

GENERAL – ELECTRICAL TESTS

158	Grounding Continuity Test	147
158.1	General	147
158.2	Test method	147
158.3	Test results	147
159	Dielectric Voltage-Withstand Test	147
159.1	General	147
159.2	Test method	147
159.3	Test results	148
160	Low Voltage Hinged or Movable Part Cycling Test	148
160.1	General	148
160.2	Test method	148
160.3	Test results	148
161	Leakage Current Measurement Test	148
161.1	General	148
161.2	Test method	149
161.3	Test results	150
161A	Input Power Measurement	150

INCANDESCENT UNIT TESTS

162	Torchiere Input Test	150
162.1	General	150
162.2	Test method	150
162.3	Test results	151
163	Lamp Harp Torque Test	151
163.1	General	151
163.2	Test method	151
163.3	Test results	152
164	Lampshade Ease of Ignition Test	152
164.1	General	152
164.2	Test method	152
164.3	Test results	152

TUNGSTEN-HALOGEN UNIT TESTS

165	Tungsten Halogen Lamp Adjacent Surfaces and Overlapping Abnormal Operation Tests ...	153
165.1	General.....	153
165.2	Test method – general.....	153
165.3	Test method – severe condition.....	154
165.4	Test method – vertical surface.....	154
165.5	Test method – supporting surface.....	154
165.6	Test method – overhead surface.....	154
165.7	Test method – overlamping.....	155
165.8	Test results.....	155
166	Tungsten-Halogen Lamp Guard, Lamp Containment Barrier, and UV Filter Security Test	155
166.1	General.....	155
166.2	Test method.....	155
166.3	Test results.....	156
167	Tungsten-Halogen Torchere Abnormal Operation Test.....	156
167.1	General.....	156
167.2	Test method.....	156
167.3	Test results.....	157
168	Tungsten-Halogen Torchere Vertical Wall Test.....	157
168.1	General.....	157
168.2	Test method.....	158
168.3	Test results.....	158
169	Tungsten-Halogen Torchere Stability Test.....	158
169.1	General.....	158
169.2	Test method.....	158
169.3	Test results.....	158
170	Tungsten-Halogen Torchere Flexible or Articulated Arm Stop Test.....	159
170.1	General.....	159
170.2	Test method.....	159
170.3	Test results.....	159
171	<i>Reserved for future use</i>	159
172	Polymeric Lamp Containment Barrier Test.....	159
172.1	General.....	159
172.2	Test method.....	159
172.3	Test results.....	160
173	Interlock Switch Endurance Test.....	160
173.1	General.....	160
173.2	Test method.....	160
173.3	Test results.....	160
174	Heat Flux Density Measurement Test.....	160
174.1	General.....	160
174.2	Test method.....	161
174.3	Test results.....	161

FLUORESCENT UNIT TESTS

175	Abnormal Operation – Shorted Starter Test	162
175.1	General.....	162
175.2	Test method.....	162
175.3	Test results.....	162

HIGH-INTENSITY-DISCHARGE UNIT TESTS

176	Glass Impact Test.....	162
176.1	General.....	162
176.2	Test method.....	162
176.3	Test results.....	163

177 Glass Thermal Shock/Containment Test..... 163
 177.1 General..... 163
 177.2 Test method 163
 177.3 Test results..... 163

SURFACE MOUNTED UNIT FOR WALL OR UNDERSHELF MOUNTING TESTS

178 Mounting Means Test – Surface Mounted Unit 163
 178.1 General 163
 178.2 Test method 163
 178.3 Test results..... 164

CORD AND CHAIN SUSPENDED UNIT TESTS

179 Mounting Means Test – Chain and Suspended Units 164
 179.1 General..... 164
 179.2 Test method – general 164
 179.3 Test method – swag unit 164
 179.4 Test method – hanging unit..... 164
 179.5 Test results..... 164
 180 Test for Suspended Toys 165
 180.1 General..... 165
 180.2 Test method 165
 180.3 Test results..... 165

CLAMP-ON UNIT TESTS

181 Mounting Means Test – Clamp-On Unit 165
 181.1 General..... 165
 181.2 Test method 166
 181.3 Test results..... 166

TRACK-STYLE UNIT TESTS

182 Mechanical Means of Polarity Test..... 167
 182.1 General..... 167
 182.2 Test method 167
 182.3 Test results..... 167
 183 Track Clip Securement Test..... 167
 183.1 General..... 167
 183.2 Test method 167
 183.3 Test results..... 167

PORTABLE LUMINAIRE KIT AND SUBASSEMBLY TEST

184 Assembly and Installation Test..... 168
 184.1 General..... 168
 184.2 Test method 168
 184.3 Test results..... 168

WORK LIGHT TESTS

185 Guard Securement Test 168
 185.1 General..... 168
 185.2 Test method 168

WET LOCATION USE TESTS

186	Rain and Sprinkler Tests	169
	186.1 General.....	169
	186.2 Test method – general.....	169
	186.3 Test method – rain test.....	169
	186.4 Test method – sprinkler test.....	172
	186.5 Test results.....	172
187	Polymeric Thermal Conditioning Test	173
	187.1 General.....	173
	187.2 Test method	173
	187.3 Test results.....	173
188	Gasket Accelerated Aging Test.....	173
	188.1 General.....	173
	188.2 Test method A	173
	188.3 Test results A.....	174
	188.4 Test method B	174
	188.5 Test results B.....	174
189	Gasket Adhesion Test.....	174
	189.1 General.....	174
	189.2 Test method A	174
	189.3 Test results A.....	174
	189.4 Test method B	174
	189.5 Test results B.....	175
190	Paint Adhesion Test.....	175
	190.1 General.....	175
	190.2 Test method	175
	190.3 Test results.....	175

PORTABLE HAND LIGHT TESTS

191	Abnormal Operation Tests	175
	191.1 General.....	175
	191.2 Continuous operation.....	175
	191.3 Manual manipulation (following continuous operation)	176
	191.4 Mechanical manipulation	176
192	Crush Test	178
	192.1 General.....	178
	192.2 Test method	178
	192.3 Test results.....	178
193	Drop Test	178
	193.1 General.....	178
	193.2 Test method	178
	193.3 Test results.....	179
194	Conductor Secureness Test	179
	194.1 General.....	179
	194.2 Test method	179
	194.3 Test results.....	179
195	Dielectric Voltage-Withstand Test.....	179
	195.1 General.....	179
	195.2 Test method	179
	195.3 Test results.....	179
196	Hand Light Guard Securement Test	180
	196.1 General.....	180
	196.2 Test method	180

BATTERY TESTS

197	General	180
	197.1 Charge rate	180
	197.2 Battery charging circuit abnormal tests	180

MARKINGS

198	General	181
	198.1 Form	181
	198.2 Form "A" marking label	182
	198.3 Tag type markings	183
	198.4 Pictograph type markings	183
	198.5 Manufacturer's identification	183
	198.6 Electrical ratings	183
	198.7 Mounting orientation	184
	198.8 Hot surface marking	184
	198.9 Interconnected units	184
	198.10 Units with integral shelf, rack, or table	185
	198.11 Resemblance to toy	185
	198.12 Marking for luminaires containing hazardous substances	185
199	Non-Integral Power Supply	185
200	Portable Luminaires with Batteries	185
201	Incandescent Units	186
	201.1 Lamp replacement	186
	201.2 Incandescent units shipped without lampshade	187
	201.3 Removal of dust cover	187
202	Tungsten Halogen Units	187
	202.1 Lamp replacement – single envelope lamp	187
	202.2 Lamp replacement – double envelope lamp	187
	202.3 Risk of fire and injury warnings	188
	202.4 Five foot minimum mounting	189
	202.5 Date code	189
203	Fluorescent Units	189
	203.1 Lamp replacement	189
204	Light Emitting Diode (LED) Units	190
205	High-Intensity-Discharge Units	191
	205.1 Lamp replacement	191
	205.2 Double-ended metal halide lamp	192
206	Cord and Chain Suspended Units	192
207	Portable Cabinet Lights	192
	207.1 Identification	192
	207.2 Shortened cord	192
	207.3 Interconnecting receptacle	192
	207.4 Portable cabinet light accessory	192
208	Units for Use with Office Furnishings	192
209	Convertible Units	193
210	Interchangeable Units	193
211	Track-Style Units	193
212	Portable Luminaire Kits and Subassemblies	194
213	Portable Luminaire Accessory	194
214	Work Light	194
214A	Damp Location Use	195
215	Wet Location Use	195
216	Portable Hand Lights	195
217	Portable Luminaires with Batteries	196

INSTRUCTIONS

218	General	196
	218.1 Location	196
	218.2 Assembly instructions	196
	218.3 Polarization instructions	197
	218.4 Interconnected units.....	197
	218.5 Pin type attachment plug	197
	218.6 Shortened cord.....	197
	218.7 Alternate supply connection.....	197
	218.8 Attachment plugs complying with foreign standards.....	198
	218.9 Portable luminaires with batteries.....	198
219	Incandescent Units	198
	219.1 Units shipped without lampshade	198
220	Tungsten-Halogen Units	198
221	Surface Mounted Units	199
	221.1 General.....	199
	221.2 Appliance mounting	200
222	Cord and Chain Suspended Units	200
223	Portable Cabinet Lights.....	200
	223.1 Installation instructions	200
	223.2 Markings	201
224	Portable Cabinet Light Accessory	201
225	Units for Use with Office Furnishings.....	201
226	Convertible Units	201
	226.1 General.....	201
	226.2 Swag to chandelier installation.....	202
	226.3 Surface mount installation	202
227	Track-Style Units	202
228	Portable Luminaire Kits and Subassemblies	203
229	Portable Luminaire Accessory	203
230	Wet Location Use	203
231	Portable Hand Lights	204

MANUFACTURING AND PRODUCTION TESTS

232	Dielectric Voltage Withstand Test.....	204
233	Polarity Test	204
234	Continuity of Grounding Connection Test.....	204

SUPPLEMENT SA (Normative) – REQUIREMENTS FOR BATTERY-OPERATED PORTABLE LUMINAIRES

SA1	Scope	205
SA2	Glossary	205
SA3	Mechanical construction	205
SA4	Electrical Construction	205
SA5	Performance	206
	SA5.1 Normal temperature test	206
	SA5.2 Impact resistance.....	206
	SA5.3 Water entry resistance.....	206
	SA5.4 Limited power capacity test	207
	SA5.5 Battery charge tests	207
	SA5.6 Photobiological safety assessment.....	207
SA6	Markings	207
SA7	Instructions	207

APPENDIX A Standards for Components

APPENDIX B (Informative) Manufacturing and Production Tests

B1	Insulation Integrity.....	210
	B1.1 General	210
	B1.2 Dielectric Voltage Withstand Test.....	210
	B1.3 DC Insulation Resistance Measurement Test.....	211
B2	Polarity Test.....	211
B3	Continuity of Grounding Connection Test	212

ULNORM.COM : Click to view the full PDF of UL 153 2025

No Text on This Page

ULNORM.COM : Click to view the full PDF of UL 153 2025

INTRODUCTION

1 Scope

1.1 These requirements cover portable luminaires and subassemblies whose primary function is task or ambient illumination. These products are intended for use in accordance with the National Electrical Code, ANSI/NFPA 70.

1.2 These requirements cover portable luminaires intended for connection to a nominal 120-volt, 15- or 20-ampere branch circuit, by means of an attachment plug, a mating connector assembly, or a non-integral power supply.

1.2.1 These requirements also cover portable luminaires intended to receive power through a USB connection, or power over ethernet (POE) using category 5 (CAT5) or similar cables and 8P8C (RJ45) connectors. These portable luminaires do not include and need not be marked to specify their power source.

1.2.2 The requirements in Supplement [SA](#) also cover battery-operated portable luminaire intended to be used while disconnected from any external power source.

1.3 Light emitting diode (LED) components and subassemblies integral to a portable luminaire covered by this standard shall comply with the applicable requirements of the Standard for Light Emitting Diode (LED) Equipment for Use in Lighting Products, UL 8750.

1.4 These requirements do not cover portable luminaires within the scope of the following standards:

Standard for Electric Signs, UL 48

Standard for Portable Sun/Heat Lamps, UL 482

Standard for Seasonal and Holiday Decorative Products, UL 588^a

Standard for Luminaires for Use in Hazardous (Classified) Locations, UL 844

Standard for Household and Commercial Furnishings, UL 962^b

Standard for Electric Aquarium Equipment, UL 1018

Standard for Temporary Lighting Strings, UL 1088

Standard for Relocatable Power Taps, UL 1363^c

Standard for Flashlights, UL 1576

Standard for Direct Plug-In Nightlights, UL 1786

Standard for Rope Lights, UL 2388

Standard for Horticultural Luminaire Systems, UL 8800

Standard for Portable UV Germicidal Equipment With Uncontained UV Sources, UL 8803

^a UL 588 and UL 153 can be used for string lights for all-year use that use 18 AWG and larger cord sizes. UL 588 is the only applicable Standard for String lights for all-year use and lighting strings employing cords smaller than 18 AWG. All other seasonal and holiday decorative products, regardless of the size of the cord, are only covered under the scope of UL 588.

^b UL 962 applies where furnishings have integral illumination intended for aesthetic purposes and with only a modest contribution to ambient illumination levels.

^c UL 1363 applies for relocatable power taps where illumination is a secondary function of the device.

1.5 Work lights and portable hand lights that include primary or secondary battery packs are within the scope of the Standard for Flashlights and Lanterns, UL 1576.

2 Glossary

2.1 For the purpose of these requirements the following definitions apply.

2.2 ADAPTER – A component of a lighting assembly intended to mate with a base and provide mechanical attachment and electrical connection for interchangeable lighting assemblies.

2.3 ADAPTER FOR TRACK STYLE UNIT – A component of a lighting assembly intended to mate with a track and provide mechanical securement and electrical connection for track-style type units.

2.4 BALLAST – A current limiting device required to start and operate fluorescent lamps.

2.5 BASE – A weighted free standing or wall-mounted, cord-connected support that provides the electrical supply to one or more replaceable or interchangeable lighting assemblies.

2.5.1 BATTERY CELL – The basic manufactured unit of a battery. Provides electrical energy by direct conversion of chemical energy and designed to be charged electrically. Consists of electrodes, separators, electrolyte, container and terminals.

2.6 BATTERY, PRIMARY – A battery that can only be discharged once, not designed to be electrically recharged.

2.7 BATTERY, SECONDARY – A battery intended to be charged and discharged multiple times under prescribed rates of charging and discharging in accordance with the battery manufacturer's recommendations.

2.8 BULB (LAMP) – See [2.25](#).

2.9 CLASS 2 CIRCUIT – A circuit supplied by an isolating source whose electrical output complies with the requirements of the Standard for Class 2 Power Units, UL 1310, the LPS (limited power source) parameters of the Standard for Information Technology Equipment – Safety – Part 1: General Requirements, UL 60950-1 or the Standard for Audio/Video, Information and Communication Technology Equipment – Part 1: Safety Requirements, UL 62368-1, the LVLE (low voltage limited energy) parameters of the Standard for Light Emitting Diode (LED) Equipment for Use in Lighting Products, UL 8750, or the Limited Power Source Test of the Standard for Household and Commercial Batteries, UL 2054. Also includes POE and USB power sources.

2.10 CLEARANCE DISTANCE – The shortest distance measured through air between conductive parts.

2.11 COMBUSTION – Burning; or a chemical process (as an oxidation) accompanied by the evolution of light and heat. Examples of combustion are any blackening or disintegration, glowing, flaming or charring of any material or test indicators such as tissue paper, cheesecloth or wood.

2.12 COMPACT FLUORESCENT LAMP – A fluorescent lamp that is formed such that both ends fit into a support that is inserted into a single lampholder.

2.12.1 CONVENIENCE RECEPTACLE – A 15- or 20-amp receptacle suitable for a NEMA-style plug (see [32.1](#)) without a dedicated or defined load and intended for only occasional use. It may be integral with the portable luminaire body or at the end of an attached load-side cord. Load-side connectors or receptacles specifically for interconnected units (per Section [33](#)) are not considered convenience receptacles, regardless of their configuration.

2.13 CONVERTIBLE UNIT – A portable luminaire provided with instructions and a kit that converts the portable luminaire to a fixed luminaire (lighting fixture).

2.14 DECORATIVE PART – A part whose total or partial destruction does not affect intended performance of the portable luminaire.

2.15 DOUBLE INSULATION – An insulation system comprised of basic and supplementary insulation, with the two insulations physically separated and arranged so that they are not simultaneously subjected to the same deteriorating influences (temperature, contaminants, and the like) to the same degree. Each insulation layer (basic and supplementary) is individually able to comply with the spacings and dielectric voltage withstand requirements of this standard.

2.16 END CAP – A cover intended to close the open end of a track.

2.17 EXPOSED PART – A part that is not enclosed to prevent contact.

2.17.1 FREESTANDING PORTABLE LUMINAIRE – A portable luminaire designed to be stable and intended to be operated unattended while on a horizontal surface (e.g., table or floor).

2.18 FRICTION MATERIAL – Rubber or elastomer with or without dimples or ridges. Plastic or metal with or without dimples or ridges is not determined to be a friction material.

2.19 GUARD – That portion of the portable luminaire that prevents inadvertent contact with the lamp. Is able to be integral with the shield.

2.20 HOUSED PART – A part that is prevented from being contacted by a housing that does not meet the requirements for enclosing live parts.

2.20.1 HYGROSCOPIC – A material, including those identified as deliquescent, that absorbs atmospheric moisture at normal room temperatures. Examples include salts of various types, including calcium chloride, magnesium chloride, potassium carbonate, and others.

2.21 INTERCONNECTED UNIT – A luminaire designed to receive and/or provide power to or from another luminaire through a series connection.

2.22 INTERCONNECTING CORD – A conductor running between two luminaires.

2.23 INTERLOCK SWITCH – A switch that de-energizes the lamps when the portable luminaire is opened or when the lamp is replaced.

2.24 ISOLATED SECONDARY CIRCUIT – A circuit derived from an isolated secondary winding of a transformer and that has no direct connection back to the line-connected circuit (other than through grounding means). A secondary circuit that has a direct connection back to the line-connected circuit is determined to be part of the line-connected circuit.

2.25 LAMP – A light source of any configuration (e.g., bulb, tube, LED array or module, etc.), replaceable or not, intended to illuminate the environment where the portable luminaire is located.

2.26 LAMP ADAPTER – A self-ballasted lamp with a replaceable light source.

2.27 LAMP, SELF-BALLASTED – A device provided with a lamp base and incorporating a non-replaceable light source and any additional elements necessary for starting and stabilizing operation of the light source, which cannot be dismantled without being permanently damaged. May be identified as “SBCFL” when the light source is fluorescent or “SBLED” when the light source is LED.

2.28 LAMP CONTAINMENT BARRIER – Any part of a portable luminaire that encloses the lamp.

2.29 LIGHTING ASSEMBLY, INTERCHANGEABLE – An assembly consisting of a lighting unit and an adapter. One or more lighting assemblies is used with a base to make up the portable luminaire for interchangeable lighting assemblies.

2.30 LIGHTING ASSEMBLY, TRACK-STYLE – An assembly consisting of a lighting unit and an adapter. One or more lighting assemblies is used with a track to make up the track-style type unit.

2.31 LIGHTING UNIT, INTERCHANGEABLE – An assembly that includes a lamp enclosure or lamp compartment and any components and parts required for connecting the lamp compartment or enclosure to the adapter for interchangeable lighting assemblies.

2.32 LIGHTING UNIT, TRACK-STYLE – An assembly that includes a lamp enclosure or lamp compartment and any components and parts required for connecting the lamp compartment to the adapter for the track-style type units.

2.33 LINE OF SIGHT – A straight, unbroken, unobstructed, direct line between the eye and an object (for example, the lamp).

2.34 LIVE PART – A metal or other conductive part that has a potential difference during operation with respect to ground or any other conductive part.

2.35 LOW-VOLTAGE CIRCUIT – A circuit involving an open circuit potential within the levels permitted for a Class 2 circuit.

2.36 MANUFACTURER – The organization responsible for producing or distributing the product.

2.37 NORMAL MAINTENANCE AND USE – The cleaning, adjusting, moving, maintaining, and using of the portable luminaire. Includes items such as:

- a) Replacing a lamp, starter or fuse;
- b) Adjusting an illumination level; and
- c) Removal or cleaning of all parts not secured by use of tools.

2.38 ORDINARY TOOL – A tool, such as a flat-blade or cross-head screwdriver, a nut driver, or pliers.

2.38.1 PLANT LUMINAIRE – A portable luminaire with an integral platform or container onto (or into) which a living plant is to be located, primarily for decorative purposes. There is no specific size limitation for a plant luminaire. Luminaires intended to grow plants, vegetables, or herbs on a commercial scale are better identified as “horticultural luminaires” and are not within the scope of this standard.

2.39 **PLAY VALUE** – A characteristic of products with features that promote a child's interactive exploration and use a child's imagination and ability to pretend to create enjoyable play and incorporates a child's interest to encourage repeat play. Such features may include interactive characteristics similar to those of familiar toys (i.e., stuffed animals, model vehicles with moving parts, buildings, sports equipment, cartoon characters, playhouses, or a “busy box” with lights, sliding or rotating features, or manually actuated music, and similar features), that are attractive to children eight years or less in age. Non-interactive features like decorative displays with pre-set patterns, pictures, or music may be entertaining, but do not necessarily have play value.

2.40 **POLYMERIC MATERIAL** – A material made of a chemical compound or mixture of compounds formed by polymerization and consisting of repeating structural units. Polymeric materials include thermoplastic, thermosetting, and elastomeric materials. A thermoplastic material is able to be easily softened and resoftened by repeated heating. A thermosetting material cures by chemical reaction when heated and, when cured, is unable to be resoftened by reheating. An elastomeric material is capable of being stretched at room temperature to at least twice its length under low stress and recovers to its original length when released from the stress.

2.41 **PORTABLE CABINET LIGHT** – A portable lamp intended for installation into an open or enclosed cabinet such as a china hutch, bookcase, bed headboard, or kitchen cabinet.

2.42 **PORTABLE CABINET LIGHT, POT STYLE** – A portable cabinet light intended for recessed mounting within a cavity above the shelf to which it is secured.

2.43 **PORTABLE CABINET LIGHT ACCESSORY** – Components such as interconnecting cord sets, dimmers, or switch assemblies intended to be used with portable cabinet luminaires.

2.44 **PORTABLE HAND LIGHT ACCESSORY** – A component of a hand light such as a lampholder assembly, a lamp guard with or without a hook for hanging, or a handle. These accessories are intended for assembly by the user or for use in other portable hand light applications.

2.45 **PORTABLE HAND LIGHTS** – A complete assembly consisting of a handle, a lampholder assembly, a guard and a power-supply cord.

2.46 **PORTABLE LUMINAIRE** – A portable luminaire, also commonly known as a portable lamp, as defined in the scope of the Standard. For purposes of requirements in the Standard, the term “portable luminaire,” “luminaire,” and “unit” are used interchangeably.

2.46.1 **POWER OVER ETHERNET (POE)** – A wiring system conforming to the Standard for Ethernet, IEEE 802.3, that uses category 5 (CAT5) or similar cables and connectors to concurrently carry power and data, with voltage and power within the Class 2 limits of the National Electric Code, ANSI/NFPA 70. Includes PoE (type 1, 15.4 W max), POE+ (type 2, 30 W max), and 4PPoe / PoE++ (type 3, 60 W max and type 4, 100 W max).

2.47 **POWER SUPPLY** – An electronic assembly designed to convert and regulate an electrical power source to some defined (range of) output voltage and/or current. Within the context of this standard, this term also applies to assemblies commonly referred to as ballasts, drivers, or other assemblies that perform this function.

2.48 **POWER SUPPLY, NON-INTEGRAL** – A power supply contained in a separate enclosure from that of the portable luminaire lighting assembly, electrically connected at the supply side to a nominal 120 V branch circuit and at the load side to the lighting assembly at some other voltage. Direct plug-in and through-cord power supplies are common forms of non-integral power supplies. Within the context of this definition, a power supply includes fluorescent ballasts, LED drivers, and other electronic assemblies intended to operate incandescent, electroluminescent, or other lighting source types.

2.49 POWER-SUPPLY CORD FITTER – That portion of the assembly that terminates the power-supply cord at the track, connecting the conductors to the bus bars in the track.

2.50 REACTANCE BALLAST – A ballast, the impedance of which is provided by:

- a) Inductive reactance;
- b) Capacitive reactance; or
- c) Both inductance and capacitive reactance.

2.51 REACTOR (SIMPLE REACTANCE) BALLAST – A reactance type ballast in which the impedance (inductive reactance) is provided by a single coil and core - not a transformer. A reactor ballast usually has one lead in and one lead out.

2.52 SECONDARY CIRCUIT – A circuit that is supplied by an induced voltage from a primary where a primary circuit is that supplied by a branch circuit.

2.53 SHADE – The portion of the portable luminaire within which the lamp is located. The light from the lamp is diffused, deflected, reflected, transmitted through, or absorbed by the shade. The shade may be a functional or supportive part, or a decorative part.

2.54 SIGN – A self-contained, cord or permanently-connected, electrically illuminated product, usually with advertising or other words or symbols, intended to convey information or attract attention in a commercial setting.

2.55 SODALIME GLASS – Window glass which typically has a greenish tint readily discernible by viewing the glass from the edge. It scratches easily as compared to other types of glass. Sodalime glass is not determined to be heat resistant unless it is tempered.

2.56 SUBASSEMBLY – Consists of all the parts to a portable luminaire in an easy to assemble form either for “building” a unit (such as a craft kit) or rewiring a portable luminaire. They are intended to be assembled by a person presumed to possess little or no knowledge or no knowledge of electrical circuitry.

2.57 TEMPORARY – Used only for the amount of time required to complete the job. Not intended for long term use in one location. When the job is complete, the work light is moved to the next work area or stored until the next job.

2.58 TORCHIERE – A portable luminaire supported by the floor having a bowl shaped shade with the concave surface facing upward (open top/closed bottom design) intended to provide indirect light. This includes both opaque and translucent type shades. The lamp (bulb) is typically 5 – 6 feet (1.27 – 1.52 m) above the floor and is hidden from direct view by the concave shade. A floor unit that has an adjustable bowl shaped shade where the concave surface of the shade can be directed upward to an angle greater than 45 degrees from the horizontal is also defined as a torchiere.

2.59 TRACK – An enclosure that houses the bus bars and that houses or is integral with the bus bar support. Track is usually made of extruded material that usually resembles an “H” in cross section, with two vertical members connected by a horizontal member. The bus bar support and bus bars are factory-mounted in the lower half of the “H” and the connection of lighting assemblies is accomplished through the open bottom.

2.60 TUNGSTEN-HALOGEN DOUBLE ENVELOPE LAMP – See [2.62](#). The lamp also includes an outer integral glass envelope.

2.61 TUNGSTEN-HALOGEN LAMP, SUITABLE FOR USE IN OPEN LUMINAIRE – A lamp that complies with the following:

- a) The lamp containment and UV filter requirements of UL 153 and is identified as a “Classified” lamp; or
- b) The lamp is single enveloped, complies with the Standard for Incandescent Lamps – Safety Specifications, Part 3: Tungsten Halogen Lamps (non-vehicle), ANSI/IEC C78.60432:3, and the lamp manufacturer declares on the lamp package that the lamp is suitable for use in an open luminaire; or
- c) The lamp is provided with an integral outer lamp envelope and the lamp manufacturer does not provide a caution requiring an additional lamp containment barrier or UV filter.

2.62 TUNGSTEN-HALOGEN SINGLE ENVELOPE LAMP – An incandescent lamp with a quartz or glass envelope, filled with a halogen gas, and a tungsten filament.

2.63 ULTRAVIOLET (UV) FILTER – A portion of the portable luminaire that limits ultraviolet (UV) emissions.

2.63.1 Universal Serial Bus (USB) – A wiring system for communication and power transfer between a wide range of digital devices. Several versions exist (USB 1.0, 2.0, 3.0, type C, Power Delivery), all with power levels evaluated under the Limited Power Source (LPS) protocol of the Standard for Information Technology Equipment – Safety – Part 1: General Requirements, UL 60950-1 or the Standard for Audio/Video, Information and Communication Technology Equipment – Part 1: Safety Requirements, UL 62368-1, (and similar) standard and conforming to the Class 2 limits of the National Electric Code, ANSI/NFPA 70.

2.64 USER SERVICING – See [2.37](#).

2.65.1 WATER SHIELD – A part or assembly of parts whose function is to exclude water from some portion of the portable luminaire. A water shield may additionally serve other functions.

2.66 WORK LIGHT – A cord and plug connected light for illumination of work areas such as construction sites, loading docks, and machinery work stations. Work lights are not intended to be hand held during use. Work lights are not intended for use in hazardous locations as defined in the National Electric Code, ANSI/NFPA 70.

3 Organization and Application

3.1 The requirements are organized as follows:

Construction requirements:

Sections [7](#) – [47](#) – applicable to all portable luminaires; and

Sections [48](#) – [142](#) – applicable to specific type units.

Performance tests:

Sections [143](#) – [161](#) – applicable to all portable luminaires; and

Sections [162](#) – [197](#) – applicable to specific type units.

Marking requirements:

Section [198](#) – applicable to all portable luminaires; and

Sections [199](#) – [216](#) – applicable to specific type units.

Instruction requirements:

Section [218](#) – applicable to all portable luminaires; and

Sections [219](#) – [231](#) – applicable to specific type units.

Manufacturing and production tests:

Appendix [B](#) – applicable to all portable luminaires.

3.2 A portable luminaire is capable of having multiple supplementary requirements that are applicable. For example, a work light, in addition to complying with the general and the work light sections of the standard, shall also be required to comply with the supplementary requirements for tungsten-halogen and wet location type units when these requirements are applicable. Specific unit features which limit the application of the requirement(s) are identified by headings, subheadings, or the text of the paragraph. When a product type reference is not specified, the requirement is applicable to all portable luminaires.

4 Components

4.1 Except as indicated in [4.2](#), a component of a product covered by this standard shall comply with the requirements for that component. See Appendix [A](#) for a list of standards covering components generally used in the products covered by this standard.

4.2 A component is not required to comply with a specific requirement that:

- a) Involves a feature or characteristic not required in the application of the component in the product covered by this standard, or
- b) Is superseded by a requirement in this standard.

4.3 A component shall be used in accordance with its rating established for the intended conditions of use.

4.4 Specific components are incomplete in construction features or restricted in performance capabilities. Such components are intended for use only under limited conditions, such as certain temperatures not exceeding specified limits, and shall be used only under those specific conditions.

5 Units of Measurement

5.1 Values stated without parentheses are the requirement. Values in parentheses are explanatory or approximate information.

5.2 Unless indicated otherwise, all voltage and current values specified in this standard are rms.

6 Undated References

6.1 Any undated reference to a code or standard appearing in the requirements of this standard shall be interpreted as referring to the latest edition of that code or standard.

CONSTRUCTION

MECHANICAL CONSTRUCTION – GENERAL

7 General

7.1 These requirements apply to all portable luminaires and shall be used in conjunction with the applicable supplementary requirements in this standard.

8 Assembly and Packaging

8.1 Any portion of a portable luminaire that is detachable, for shipping purposes or otherwise, shall be constructed such that it is only able to be assembled in the intended manner.

Exception: A part that is capable of being detached and assembled without compromising the mechanical or electrical integrity of the unit is capable of being assembled in more than one manner.

8.2 A portable luminaire shall be shipped from the factory in a carton or as an unpackaged complete assembly. Unassembled parts, such as glassware, chains, and similar components, when required elsewhere in the standard to accompany the product, shall be included. Decorative glassware is not required to be mounted in a frame or holder and is able to be separately wrapped to protect it from breakage during shipment.

8.2.1 A portable luminaire designed for use with a non-integral power supply shall comply with (a), (b), or (c) below:

- a) The portable luminaire is packaged with a compatible power supply;
- b) The power supply is separately shipped and is marked in accordance with Section [199](#) (markings for non-integral power supply); or
- c) The portable luminaire is intended to operate from USB, or POE power sources.

Note: See glossary for defined terms.

8.3 A portable luminaire is not required to be completely mechanically assembled when:

- a) All parts required to assemble the product, other than an ordinary tool, are provided with the unit;
- b) Splices or electrical connections are not exposed nor require completion in the assembly;
- c) The integrity of the strain relief at all wiring terminations is intact (see Strain Relief Test, Section [154](#));
- d) Assembly instructions are provided in accordance with [218.2](#); and
- e) When assembled in accordance with the manufacturer's instructions, the unit complies with the requirements in this standard.

Exception No. 1: A splice or connection is capable of being exposed or incomplete when it consists of interlocking plug/receptacle parts where the means of maintaining polarity and strain relief are inherent to the construction of the interlocking parts.

Exception No. 2: An insulation-piercing or crimp connector is capable of being exposed during the assembly operation when:

- a) All live parts of the connector and the conductors are insulated; and
- b) The splice is located such that it and the conductors connected to it are unable to inadvertently snagged or grabbed.

8.4 When wires pass through a joint between sections of a portable luminaire that are separable for packing purposes, the wires exposed at the joint prior to assembly shall contain no splices. During assembly, the joint shall either:

- a) Be limited, by threads or mechanical interference or similar, to no more than 360 degrees of rotation; or
- b) Comply with the Power Supply Cord Twist Test, Section [157](#).

8.5 When fiberglass sleeving is provided for reducing the risk of cutting or abrasion of wiring between sections of a portable luminaire separable for packing purposes as noted in [8.3](#) and [8.4](#), the sleeving shall be secured in place by means other than friction. Unless the assembly is obvious between potential pinch points, the sleeving should not require careful positioning by the user to avoid damage to the wiring.

8.6 When a splice or an electrical connection is located in a section of a portable luminaire that is separable for packing purposes, as noted in [8.3](#) and [8.4](#), the unit shall be provided with strain relief to reduce the risk of stress being transmitted to the splice or electrical connection during unpackaging and assembly of the luminaire. The strain relief shall be reliable and not easily defeated by the user. See the Strain Relief Test, Section [154](#).

8.7 When in any position of adjustment, a spring-loaded or adjustable section of a pole unit shall not transmit stress to a splice or wiring within any section of the unit either during assembly or when completely assembled. For example, the stem of an adjustable height floor unit shall raise and lower without binding or crimping the wiring of the unit.

9 Enclosures

9.1 A portable luminaire shall be constructed so that it has the mechanical strength required to resist the handling to which it is likely to be subjected, without resulting in a risk of fire, electric shock, or injury to persons due to total or partial collapse of any part with resulting reduction of spacings (electrical or thermal), loosening or displacement of parts, or other serious defects.

9.2 Where an enclosure relies on adhesive for compliance with [9.1](#), the adhesive shall be evaluated and found suitable for the associated temperature, environmental exposure, surface materials, and mechanical forces.

9.3 A portable luminaire shall be constructed so that all user servicing is completed without subjecting any wiring, component, or part to mechanical damage, or reducing electrical spacings.

9.4 A portable luminaire shall be constructed of material such as glass, metal, urea, porcelain, phenolic composition, plastic or wood. Hygroscopic materials are permitted only for portable luminaires supplied by a non-integral class 2 power supply.

9.5 A live part operating above Class 2 circuit limits shall be enclosed in a material with fire containment capability, such as metal, glass, ceramic, porcelain, or a polymeric material that complies with Section [12](#), during normal maintenance and use.

Exception No. 1: A current-carrying part of a wiring device (such as the screw shell and center contact of a lampholder, and the lampholder contacts, starter holder contacts, and similar components of a fluorescent

lamp) that are normally fitted with a functional component (a lamp, a starter, and similar components during use of the unit is not required to be additionally enclosed.

Exception No. 2: A component, such as a ballast, that has an integral outer housing that has been evaluated as an enclosure is not required to be additionally enclosed.

Exception No. 3: The power-supply cord is not required to be contained within the unit.

Exception No. 4: A wire with minimum 0.030 inch (0.76 mm) thermoplastic insulation is not prohibited from being exposed for 2 inches (50.8 mm) or less when it is securely held in place and is routed in close proximity to a portion of the lamp such that the risk of being inadvertently snagged is minimized.

Exception No. 5: A wire or bundle of wires for a lamp supported lampholder is not prohibited from being exposed when:

- a) The exposed wire or bundle of wires is covered with a glass fiber sleeve or thermoplastic tubing that extends from a point inside the enclosure to within 1/2 inch (12.7 mm) of the lampholder, and the sleeving has a wall thickness of at least 0.017 inch (0.42 mm);
- b) The hole in the housing through which the nonenclosed wires emerge is not larger than 5/8 inch (15.9 mm) diameter, or has an area of 0.31 square inch (200 mm²) when other than round in shape; and
- c) The wires are provided with a strain relief device at the portable luminaire end, and the device complies with the Strain Relief Test, Section [154](#).

Exception No. 6: A wire or cord with a minimum 0.030 inch (0.76 mm) thermoplastic insulation and an insulation-piercing or a crimp connector having all live parts of the connector and the conductors insulated are only required to be housed within the unit such that they are unable to be grasped, pulled, or inadvertently snagged. For instance, it meets the intent of the requirement to have a metal base with a felt pad for a bottom cover where the felt pad is secured by an adhesive and the weight of the unit.

Exception No. 7: Wood and other organics are permitted for enclosing combustible parts that are insulated with material rated V2 or better.

10 Metal Thickness for Enclosures

10.1 The thickness of sheet metal used in a portable luminaire shall not be less than specified in [Table 10.1](#).

Exception No. 1: A form of construction that uses metal having a thickness less than specified is able to be used when investigated and found to comply with the applicable tests in Metal Thickness Equivalency Tests, in the Standard for Luminaires, UL 1598.

Exception No. 2: The thickness of metal is not specified for:

- a) A decorative part;
- b) A reflector part that does not form part of the enclosure; or
- c) Any part not required to serve as the enclosure, provide structural integrity, or act as support of a wiring device.

Table 10.1
Thickness of sheet metal

Largest dimension	Conditions of use	Minimum thickness of sheet metal					
		Uncoated		Zinc-coated		Copper, brass, or aluminum	
		Inch	(mm)	Inch	(mm)	Inch	(mm)
Not more than 26 inches (660 mm)	Component Support	0.020	(0.51)	0.023	(0.58)	0.025	(0.64)
		0.016 ^a	(0.41) ^a	0.019 ^a	(0.48) ^a	0.020 ^a	(0.51) ^a
Not more than 26 inches (660 mm)	No Component Support	0.016	(0.41)	0.019	(0.48)	0.020	(0.51)
		0.013 ^a	(0.33) ^a	0.016 ^a	(0.41) ^a	0.016 ^a	(0.41) ^a
Not more than 50 inches (1.27 m)	Component Support	0.026	(0.66)	0.029	(0.74)	0.032	(0.81)
		0.020 ^a	(0.51) ^a	0.023 ^a	(0.58) ^a	0.025 ^a	(0.64) ^a
Not more than 50 inches (1.27 m)	No Component Support	0.020	(0.51)	0.023	(0.58)	0.025	(0.64)
		0.016 ^a	(0.41) ^a	0.019 ^a	(0.48) ^a	0.020 ^a	(0.51) ^a
More than 50 inches (1.27 m)	Component Support	0.042	(1.07)	0.045	(1.14)	0.050	(1.27)
		0.031 ^a	(0.79) ^a	0.034 ^a	(0.86) ^a	0.040 ^a	(1.02) ^a
More than 50 inches (1.27 m)	No Component Support	0.031	(0.79)	0.034	(0.86)	0.040	(1.02)
		0.026 ^a	(0.66) ^a	0.029 ^a	(0.74) ^a	0.032 ^a	(0.81) ^a

^a Only when the surface involved is curved, ribbed, flanged, or reinforced with additional metal. A surface is determined to be flanged when the two opposite longer sides are bent at right angles to the surface to form 1/2 inch (12.7 mm) or wider flanges.

10.2 [Table 10.1](#) applies to any single surface or single flat sheet. Values for the thickness of sheet steel are based on uncoated material. Rigid members consisting of 1/2 by 1/2 inch (12.7 by 12.7 mm), 90 degree angle strips formed of sheet steel not less than 0.031 inch (0.79 mm) thick, or flat steel bars not less than 3/8 inch (9.5 mm) wide and 1/8 inch (3.2 mm) thick shall be used to reinforce and divide a larger area into sections for which lighter metal is able to be used. Such reinforcement, unless along the greater dimension of the surface, shall also be secured to the adjacent sides of the enclosure. A single sheet of metal having a bent corner that forms an angle of not more than 120 degrees is determined to be reinforced at that corner, and the thickness is based on the length and area of the maximum flat surface involved.

10.3 The minimum thickness of cast metal shall be in accordance with [Table 10.2](#).

Exception: A form of construction that uses metal having a thickness less than specified is able to be used when investigated and found to comply with the applicable tests in Metal Thickness Equivalency Tests, in the Standard for Luminaires, UL 1598.

Table 10.2
Thickness of cast metal

Metal	Minimum thickness, inch (mm)			
	At unreinforced areas		At all other areas ^a	
Die-cast metal	5/64	(2.0)	3/64	(1.2)
Cast malleable iron or permanent mold cast aluminum	3/32	(2.4)	1/16	(1.6)
Other cast metal	1/8	(3.2)	3/32	(2.4)

^a Applicable for the base of threads, and for surfaces that are curved, ribbed, or otherwise reinforced so as to meet the intent of the requirements, or for a surface of such shape or size that the required mechanical strength is provided.

10.4 Metallic tubing shall not be less than 0.040 inch (1.02 mm) thick when cut threads are employed.

10.5 Unthreaded metallic tubing or metallic tubing having rolled threads shall not be less than 0.025 inch (0.64 mm) thick.

10.6 The thickness of tubing is to be measured with a round-nose micrometer.

10.7 An enclosure, a frame, a guard, a handle, or similar part shall not be sufficiently sharp to constitute a risk of injury to persons in normal maintenance and use.

11 Corrosion Protection

11.1 Each external iron or steel surface of a portable luminaire enclosure or wireway shall be protected from corrosion.

Exception No. 1: Enclosed steel pipe stems are not required to be protected against corrosion.

Exception No. 2: Threaded holes and the cut edges and punched holes of an enclosure, and similar parts, formed of galvanized stock are not required to be protected against corrosion.

Exception No. 3: Cast materials are not required to have corrosion protection.

12 Polymeric Enclosures

12.1 A polymeric material, used as a part or all of the enclosure of a portable luminaire as specified in Enclosures, Section 9, shall have:

a) Mechanical temperature indexes (including impact) as a result of long term aging as described in the Standard for Polymeric Materials – Long Term Property Evaluations, UL 746B; and

b) Been evaluated for use in portable luminaires in accordance with the Standard for Polymeric Materials – Use in Electrical Equipment Evaluations, UL 746C.

Exception No. 1: A polymeric material used as an enclosure for a dry location unit does not require the volume resistivity test.

Exception No. 2: The distortion under load test is not required when the mold stress relief test is conducted.

Exception No. 3: For units which are not mounted to a surface, the impact test shall include the drop test, and the ball impact test is not required.

Exception No. 4: The mold-stress relief distortion test shall be conducted using the air-oven method only. The test-cell method is not required.

Exception No. 5: The input after mold stress relief distortion, the abnormal conditions test, and the severe conditions test are not required.

Exception No. 6: The mold stress relief distortion test is not required on extruded or protruded materials.

12.2 A polymeric material is relied upon to provide all or a portion of the strain relief, shall comply with the requirements of the Strain Relief Test, Section 154, after the Mold Stress Relief Distortion Test in the Standard for Polymeric Materials – Use in Electrical Equipment Evaluations, UL 746C.

13 Decorative Parts

13.1 A decorative part of polymeric material located near a lamp or other component that generates heat shall:

- a) Be present on the portable luminaire when it is temperature tested in accordance with the Normal Temperature Test, Sections [143](#) – [147](#); and
- b) Not melt or deform in any way that interferes with the normal operation of the unit or results in a risk of fire or electric shock during the temperature test.

13.2 A decorative part is able to be constructed of any material when the failure of the part does not interfere with the performance of the portable luminaire. Hygroscopic materials are permitted only for portable luminaires supplied by a non-integral class 2 power supply.

14 Enclosure Openings

14.1 An opening in a portable luminaire enclosure described in Enclosures, Section [9](#), shall comply with the requirements for the Accessibility of Live Parts, Section [23](#).

14.2 An enclosure containing an open core-and-coil device shall not contain open holes or open seams.

Exception No. 1: An opening provided for an automatic starter meets the intent of the requirement when it is no more than 1/8 inch (3.2 mm) diameter larger than the diameter of the starter.

Exception No. 2: Openings provided in through-cord transformers or direct plug-in transformers meet the intent of the requirement when the transformer complies with the Standard for Power Units Other Than Class 2, UL 1012, the Standard for Class 2 Power Units, UL 1310, or the Standards for Low Voltage Transformers – Part 1: General Requirements, UL 5085-1 and Low Voltage Transformers – Part 3: Class 2 and Class 3 Transformers, UL 5085-3.

Exception No. 3: A unit that incorporates an open coil type transformer or power supply is able to have open holes in the enclosure as specified in [Table 14.1](#) when the transformer has been determined to comply with the abnormal test specified in the Standard for Transformers and Motor Transformers for Use in Audio-, Radio-, and Television-Type Appliances, UL 1411, abnormal and short circuit test in the Standards for Low Voltage Transformers – Part 1: General Requirements, UL 5085-1 and Low Voltage Transformers – Part 3: Class 2 and Class 3 Transformers, UL 5085-3, or when a power supply has been investigated to determine compliance with the abnormal, burnout, and short-circuit tests specified in the Standard for Power Units Other Than Class 2, UL 1012, or the Standard for Class 2 Power Units, UL 1310.

Exception No. 4: An enclosure of an open coil ballast or transformer is able to have open holes in its surface when a metal baffle is provided that complies with [Figure 14.1](#) and the following:

- a) The distance between the baffle and the outer enclosure, X, shall not exceed 1/4 inch (6.4 mm).
- b) The dimensions of the baffle, Y, shall be at least the cross-sectional dimensions of the live part.
- c) The distance where the enclosure overlaps the baffle, Z, shall be at least two times the distance between the baffle and the outer enclosure (X).

Exception No. 5: A fluorescent unit that incorporates an open coil type ballast is able to have open holes in the enclosure as specified in [Table 14.1](#) when the ballast complies with the Class P requirements of the Standard for Fluorescent-Lamp Ballasts, UL 935.

Exception No. 6: A high intensity discharge unit that incorporates an open coil type ballast is able to have open holes in the enclosure as specified in [Table 14.1](#) when the ballast complies with the burnout test requirements of the Standard for High-Intensity-Discharge Lamp Ballasts, UL 1029.

Table 14.1
Maximum size of miscellaneous open holes

Opening shape	Dimension		Maximum area	
	Inch	(mm)	in ²	(cm ²)
Slot ^a	3/8	(9.6)	1-1/2	(9.68)
		(width)		
Square	1/2	(12.7)	–	–
		(side)		
Round	1/2	(12.7)	–	–
		(diameter)		
Irregular	–	–	1-1/2	(9.68)

^a An open hole between two assembled parts that does not exceed 1/32 inch (0.8 mm) is not required to comply with the area limitation.

Figure 14.1
Relationship of baffle and electrical part to prevent emission

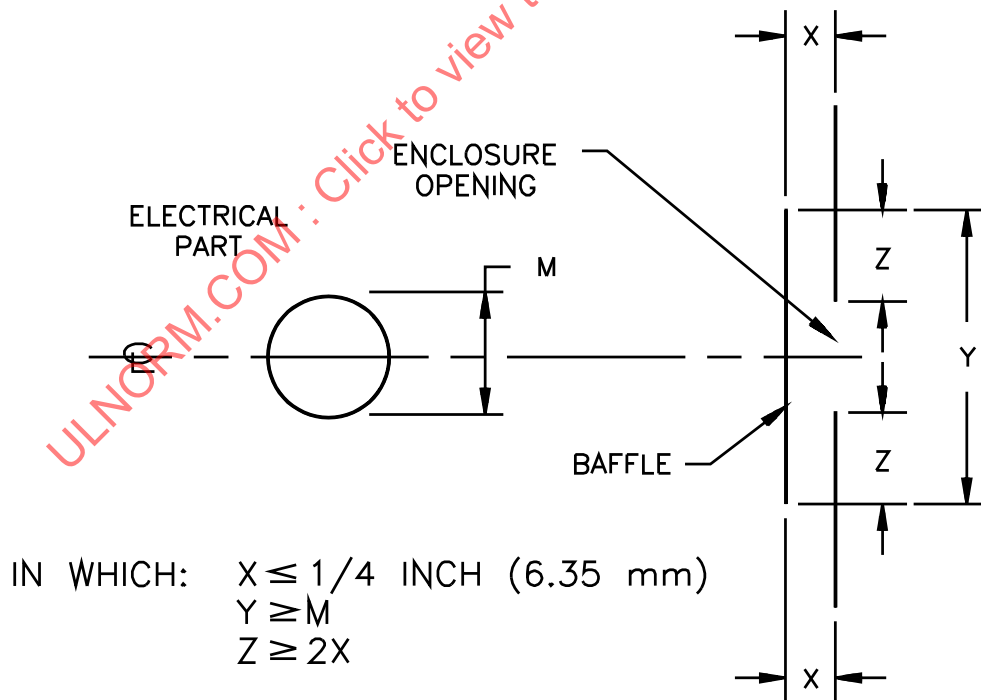

S3373

14.3 An enclosure shall not contain any opening that is usable for mounting the portable luminaire.

Exception No. 1: An opening that does not involve access to the enclosure interior is permitted.

Exception No. 2: A keyhole slot is not prohibited from being open when it is in accordance with [71.2](#).

15 Wireways and Tubing

15.1 A portable luminaire shall be constructed so that when wires are pulled through, or the unit otherwise wired, the covering or insulation on the conductors are not damaged against any surface they are able to contact. Also see Protection of Wiring, Section [30](#), for additional requirements.

15.2 Wireways shall be free from burrs and fins.

15.3 Tubing that is used as a wireway shall be free from kinks and cracks.

15.4 Screw threads of sheet metal screws and self-tapping screws shall not be exposed for a distance of more than 3/16 inch (4.8 mm) in a wireway.

Exception: The screw threads are not prohibited from being exposed for more than 3/16 inch (4.8 mm) when the wires are held away from or prevented from contacting the screw threads.

16 Shade Construction

16.1 A portable luminaire shall be shipped with a shade unless:

- a) The shade functions only as a decorative part and instructions are provided in accordance with [219.1.1](#);
- b) The design is not intended for use with a shade and instructions are provided in accordance with [219.1.2](#); or
- c) The design is not intended for and has no means to readily attach a shade.

16.2 A portable wall, table or floor type luminaire having a shade with one or more of the following features shall comply with the General – Abnormal Operation Tests, Section [149](#):

- a) The adjustable or flexible shade is able to be adjusted against the supporting surface so as to block the air flow to the lamp;
- b) There are multiple shades such that one shade directs light onto another; or
- c) The shade is able to fold up so as to block the air flow to the lamp.

16.3 A portable luminaire complying with the Temperature Test-Exempt Units requirements of Sections [49](#) or [63](#) is able to have a shade constructed of any material.

16.4 A shade shall reliably maintain its dimensions. For example, a breeze shall not be able to blow the cloth of a cloth shade closer to the lamp.

Exception: A shade is not required to reliably maintain its dimensions when the shade is used in accordance with the requirements for the minimum possible dimensions the shade is capable of attaining.

16.5 A dust cover is able to be provided over a shade only when instructions for removal are provided in accordance with [201.3](#).

Exception: The instructions are able to omitted when the dust cover does not restrict or reduce the required open area of the shade.

17 Strain Relief

17.1 A portable luminaire shall be provided with strain relief so that a pull exerted on the power supply cord is not transmitted directly to a terminal splice, or interior wiring of the unit. See Strain Relief Test, Section [154](#).

Exception No. 1: Additional strain relief is not required to be provided when the conductors of the supply cord are permanently assembled to a wiring device (such as a switch), lampholder, or similar device by the manufacturer of the wiring device, in such a manner that replacement of the cord requires the disassembly of the device by the removal of a rivet, drive screw, drive pin, or similar component.

Exception No. 2: Additional strain relief is not required to be provided when a lampholder has insulation piercing terminals and is identified as not requiring an additional strain relief device.

17.2 A metal strain-relief clamp or band used with Type SP-2 or lighter general-use, rubber-insulated cord shall be provided with auxiliary insulation over the cord for mechanical protection.

Exception: The auxiliary insulation is able to be omitted for Type SV or SVO cord.

17.3 A clamp of any material (metal or otherwise) shall not be used with Type SPE-2, SPT-2, SVT, or SVTO flexible cords, or a power supply cord for LED portable luminaires covered by the requirements of Sections [69A](#) – [69C](#).

Exception No. 1: The construction is able to be evaluated for use when the cord is protected by varnished-cloth or similar material under the clamp.

Exception No. 2: A strain-relief bushing of insulation material that has been investigated for the purpose is able to be used.

17.4 Auxiliary insulation is not required for a clamp used for strain relief of thermoplastic-insulated cord heavier than types as indicated in [17.3](#) when tested in accordance with the Strain Relief Test, Section [154](#), with no damage to the cord insulation.

17.5 When a knot in a flexible cord serves as strain relief, any surface against which the knot is able to bear or with which it is able to come in contact shall be free from projections, sharp edges, burrs, fins and similar conditions, that are capable of damaging the insulation on the conductors.

18 Portable Luminaires Having Play Value

18.1 A portion of a portable luminaire that has play value for children eight years or less in age and is intended to be removed from the unit and played with (for example a plush doll not integral with the luminaire) shall comply with the Standard Consumer Safety Specification for Toy Safety, ASTM F963. It is not possible to specify the conditions of tests for all constructions; however, the tests shall include evaluation of impact, bite, flexure, torque, tension, compression, sharp point, sharp edge, and small parts.

18.2 The portable luminaire shall not overturn when tested in accordance with the Stability Test, Section [153](#), with a 15 degree inclined plane.

18.3 A toy or stuffed animal suspended from a unit shall be designed for unexpected, forceful removal and shall comply with the requirements in the Test for Suspended Toys, Section [180](#).

18.4 The portable luminaire shall be marked in accordance with the requirements in [198.11](#).

Exception: The marking is able to be modified to indicate that the risks are associated with the luminaire portion and not to the separable portion having play value.

19 Resistance to Liquid Damage

19.1 When a portable luminaire is intended to be used where the deterioration or breakage of a liquid container, seal, or similar component increases the risk of electric shock or liquid spillage, the container, seal, or similar component shall be resistant to deterioration from the liquid intended to be used in contact with that component. The liquid shall be evaluated with respect to its toxic, acid, alkaline, flame and conductive properties. The determination of resistance to deterioration is based upon the material comprising the container, seal, or similar component, its size and shape, the mode of application, and other factors.

19.2 Deleted

20 Portable Luminaire Containing Hazardous Substance

20.1 A portable luminaire containing a hazardous substance, such as the mixture of chemicals used as decorative fluid in lava-type lamps, shall be evaluated with respect to ease of ignition, and whether the substance is toxic. The risk of injury shall be assessed on the basis of the amount of the substance or concentration and a one time exposure due to an accidental spill. Inhalation of vapors, contact with skin or eyes, and ingestion are to be considered as probable events. Chemical changes due to exposure to light (UV) and heat (operating temperature) also are to be determined.

20.2 A container of a hazardous substance shall not be adversely affected by the substance. Gaskets, seals, and caps shall not be adversely affected by the substance.

20.3 Soft glass shall not be used as a container of a hazardous substance.

20.4 The unit shall comply with the marking in [198.12](#).

20A Plant Luminaires

20A.1 General

20A.1.1 A portable luminaire intended to support or contain a plant shall be additionally evaluated for compliance with this section. This intent and the applicability of this section is to be determined by the design of the product, the use instructions, or the claims of the producer.

20A.1.2 For the purpose of this Standard and in the context of clause [1.1](#), plant hosting is considered a “task”. However, a portable luminaire may provide ambient lighting in addition to this task lighting.

20A.1.3 Portable luminaires intended for commercial-scale plant growth operations are not within the scope of this standard. Portable luminaires subject to the requirements of this section are limited to those intended for a residential setting where the plant is a peripheral and small scale use of the space.

20A.1.4 A portable plant luminaire whose light source may emit hazardous UV, blue, or infrared radiation shall qualify as Risk Group 0 when subjected to the Photobiological Safety Assessment of UL 8800, Standard for Horticultural Lighting Equipment and Systems.

NOTE: Standard incandescent or fluorescent lamps, and LEDs operating only in the visible light spectrum (400 – 700 nm), are not subject to this requirement.

20A.2 Resistance to moisture

20A.2.1 If the intended use of the portable luminaire involves introducing water (or other liquids) in the vicinity of any parts operating above Class 2 voltage limits for wet locations, the portable luminaire shall be evaluated for compliance with the Leakage Current Measurement Test, Section [161](#).

20A.3 Resistance to chemicals

20A.3.1 User instructions shall be reviewed for all chemical agents (fertilizers, soil or water supplements, or similar) that the manufacturer identifies as eligible for use with the portable luminaire. If the degradation of any portable luminaire materials could result in increased risk of fire or electric shock injury when exposed to these agents, at least one of the following mitigations are required:

- a) The material(s) shall be evaluated and determined to be adequately resistant to the degrading effects of the agent(s).
- b) The luminaire design and user instructions shall provide sufficient guidance to preclude exposure of the material(s) to the agent(s).

20A.3.2 If either mitigation (a) or (b) from [20A.3.1](#) is applicable, the instructions shall also provide guidance for detecting early indications of material degradation and steps to either arrest further development (i.e., stop using certain agents) or to halt all use of the portable luminaire.

20A.4 Lamp replacement

20A.4.1 If the portable luminaire has a user-replaceable light source, the user instructions shall provide guidance for acquiring a suitable replacement light source. This is in addition to the lamp replacement markings of Sections [201](#) – [205](#), as applicable. The instructions shall include the statement “Replace only with a light source of similar spectral bandwidth emissions”, or similar wording. A statement referring to a specific light source (i.e., catalog number) provided by the producer and designed for the same spectral output is a permitted alternative to this statement.

ELECTRICAL CONSTRUCTION – GENERAL

21 General

21.1 These requirements apply to all portable luminaires and shall be used in conjunction with the applicable supplementary requirements in this standard.

22 Assembly and Packaging

22.1 A portable luminaire shall be completely wired with each electrical component mounted in place and with each splice and connection completed.

Exception No. 1: A detachable power-supply cord is able to be disconnected from the product, as long as it is packaged with the product.

Exception No. 2: A portable luminaire consisting of a wiring harness that snap-fits into a decorative housing is not required to be assembled when such assembly precludes required packaging of the housing for shipping. For example, a ceramic or glass figurine requires packaging material inside and outside to prevent breakage during shipping.

Exception No. 3: Pendant switches (through cord) are able to be shipped unattached with the unit when installation instructions are included to indicate the intended power supply cord is Type SPT-2.

Exception No. 4: Attachment plugs with pin type (insulation piercing) terminals are able to be shipped unattached with the unit when installation instructions are included. See [32.4](#).

23 Accessibility of Live Parts

23.1 Each part or device that is required by Enclosures, Section [9](#), to be enclosed shall be located or shielded so that it is not accessible to unintentional contact by persons during normal use, including relamping, replacement of an automatic starter, or other user maintenance services.

Exception No. 1: An uninsulated live part that operates at a potential of 30 volts rms or less and 42.4 volts peak and is able to be accessible in accordance with Secondary Low Voltage Circuits, Section [38](#).

Exception No. 2: Wiring that is visible and follows the contour of the portable luminaire is able to be accessible during relamping, when it is not spliced and strain relief is maintained at all wiring terminations.

23.2 A live part is determined to be inaccessible when a probe as illustrated in [Figure 23.1](#) is unable to be manipulated such that it touches any part. The probe is to be articulated into any configuration and rotated or angled to any capable position before, during, or after inserting into the opening.

ULNORM.COM : Click to view the full PDF of UL 153 2025

Figure 23.1
Accessibility probe

