



UL 1286

STANDARD FOR SAFETY

Office Furnishing Systems

[ULNORM.COM](https://ulnorm.com) : Click to view the full PDF of UL 1286 2022

[ULNORM.COM](https://www.ulnorm.com) : Click to view the full PDF of UL 1286 2022

UL Standard for Safety for Office Furnishing Systems, UL 1286

Sixth Edition, Dated June 29, 2022

SUMMARY OF TOPICS

This new edition of ANSI/UL 1286 dated June 29, 2022 is being issued to Correct Cross References, Address Mandatory Language, Reflect Standards Writing Conventions, Clarify Requirements, And Other Similar Changes.

The revised requirements are substantially in accordance with Proposal(s) on this subject dated April 15, 2022.

All rights reserved. No part of this publication may be reproduced, stored in a retrieval system, or transmitted in any form by any means, electronic, mechanical photocopying, recording, or otherwise without prior permission of UL.

UL provides this Standard "as is" without warranty of any kind, either expressed or implied, including but not limited to, the implied warranties of merchantability or fitness for any purpose.

In no event will UL be liable for any special, incidental, consequential, indirect or similar damages, including loss of profits, lost savings, loss of data, or any other damages arising out of the use of or the inability to use this Standard, even if UL or an authorized UL representative has been advised of the possibility of such damage. In no event shall UL's liability for any damage ever exceed the price paid for this Standard, regardless of the form of the claim.

Users of the electronic versions of UL's Standards for Safety agree to defend, indemnify, and hold UL harmless from and against any loss, expense, liability, damage, claim, or judgment (including reasonable attorney's fees) resulting from any error or deviation introduced while purchaser is storing an electronic Standard on the purchaser's computer system.

ULNORM.COM : Click to view the full PDF of UL 1286 2022

No Text on This Page

ULNORM.COM : Click to view the full PDF of UL 1286 2022

JUNE 29, 2022



ANSI/UL 1286-2022

1

UL 1286

Standard for Office Furnishing Systems

First Edition – September, 1984

Second Edition – April, 1988

Third Edition – April, 1993

Fourth Edition – October, 1999

Fifth Edition – August, 2008

Sixth Edition

June 29, 2022

This ANSI/UL Standard for Safety consists of the Sixth Edition.

The most recent designation of ANSI/UL 1286 as an American National Standard (ANSI) occurred on June 24, 2022. ANSI approval for a standard does not include the Cover Page, Transmittal Pages, and Title Page.

Comments or proposals for revisions on any part of the Standard may be submitted to UL at any time. Proposals should be submitted via a Proposal Request in UL's On-Line Collaborative Standards Development System (CSDS) at <https://csds.ul.com>.

UL's Standards for Safety are copyrighted by UL. Neither a printed nor electronic copy of a Standard should be altered in any way. All of UL's Standards and all copyrights, ownerships, and rights regarding those Standards shall remain the sole and exclusive property of UL.

COPYRIGHT © 2022 UNDERWRITERS LABORATORIES INC.

No Text on This Page

ULNORM.COM : Click to view the full PDF of UL 1286 2022

CONTENTS

INTRODUCTION

1 Scope7
 2 Glossary7
 3 Components13
 4 Units of Measurement14
 5 Referenced Publications14

CONSTRUCTION

6 General16
 7 Accessibility of Electrical Component Parts17
 8 Accessories17

ELECTRICAL CONSTRUCTION

9 Contacts18
 10 Power-Supply Connections19
 10.1 General19
 10.2 Permanently connected systems19
 10.3 Cord-connected systems21
 11 Internal Wiring21
 12 Grounding23
 13 Electrical Connecting Assemblies24
 13.1 Unit-to-unit, pass-through-unit, and top- and base-feed electrical connecting assemblies24
 13.2 System jumpers26
 13.3 Mating connectors27
 13.4 Convenience outlets27
 14 Strain Relief29
 15 Bushings29
 16 Spacings29
 17 Office Furnishing Lighting Units29

STRUCTURAL CONSTRUCTION

18 Mechanical Assembly30
 18.1 General30
 18.2 Panels31
 18.3 Fabric Partitions31
 18.4 Cord channels31
 18.5 Raceway32
 18.6 Mechanical connectors32
 18.7 Glass panels32
 18.8 Protection against corrosion33
 18.9 Flammability of materials33
 18.10 Monitor arms33
 18.11 Video displays34

ELECTRICAL PERFORMANCE

19 Grounding-Impedance Test35

20	Dielectric Voltage-Withstand Test	36
21	Temperature Test	36
	21.1 Accessories	36
	21.2 Lighting attachments	37
22	Strength of Enclosure Test	38
	22.1 Snap-fit cover for enclosures	38
	22.2 Impact test – furnishing-supporting enclosures	38
23	Tightening Torque Test.....	38
24	Electrical Connecting Assemblies Test	39
25	Strain-Relief Tests	40
	25.1 General.....	40
	25.2 Top- and base-feed connections	40
	25.3 Unit-to-unit and pass-through-unit electrical connections	41
26	Conductor Secureness Test	41
27	Mating Connector Separation Tests	42
28	Spill Test.....	42
	28.1 Procedure	42
	28.2 Spill test dielectric voltage-withstand test.....	45
29	Knockout Test	45

STRUCTURAL PERFORMANCE

30	General	46
31	Functional and Proof Load Tests.....	47
32	Panel Systems with Cross-Members Over Walkways.....	47
33	Video Display Mounting System Tests.....	48
	33.1 Cycling test for articulating video mounts	48
	33.2 Proof load securement test	49
	33.3 Monitor arm tests	50
34	Glass Panel Tests.....	50
	34.1 Impact	50
	34.2 Retention	50
35	Mechanical Connector Tests	50
	35.1 Conditioning.....	50
	35.2 Flexing.....	51
36	Resistance to Corrosion Test.....	52
37	Trial Installation Test.....	52

MARKINGS

38	Details	52
39	Installation and Operating Instructions	55

MANUFACTURING AND PRODUCTION LINE TESTS

40	Grounding Continuity Test.....	57
41	Dielectric Voltage-Withstand Test	57

ANNEX A (informative) – MODULAR PRE-WIRED OFFICE FURNISHING FLOOR RACEWAY SYSTEMS

INTRODUCTION

A1	Scope	59
A2	Glossary.....	59

CONSTRUCTION

A3 Accessible Routes 59
 A3.1 Reduction of trip hazard 59
 A3.2 Slip resistance of floor surface materials 60
 A4 Mounting 60
 A5 Wiring Devices 60
 A6 Electrical Continuity 60
 A7 Grounding and Bonding 61
 A8 Accessibility of Parts 61
 A9 Conductor Fill Requirements 62
 A10 Mechanical Assembly 62
 A11 Corrosion Protection 63
 A11.1 General 63
 A11.2 Zinc coatings 63
 A11.3 Nonmetallic coatings 63
 A12 Power-Supply Connections 64
 A13 Mating Connectors 64
 A14 Convenience Receptacles 64
 A15 Outlet Boxes for Use with Pre-Wired Office Furnishing Raceway Wiring Systems 65
 A16 Gaskets and Seals 65
 A17 Cover Plates 65

PERFORMANCE

A18 Electrical Resistance Test 66
 A18.1 Individual pieces 66
 A18.2 Across joints 66
 A19 Crush Resistance 66
 A20 Deflection Test 67
 A21 Resistance to Vertical Impact 67
 A22 Resistance to Horizontal Impact 67
 A23 Temperature Test 68
 A24 Conductor Secureness Test 69
 A25 Fault Current Test 70
 A26 Receptacle Secureness Test 70
 A27 Air-Circulating Oven Conditioning Test for Gaskets and Seals 71
 A28 Water Exclusion Test 71
 A29 Volume Measurement of Raceways 71

MARKING AND INSTALLATION INSTRUCTIONS

A30 Details 72

ANNEX B (normative) – OFFICE FURNISHING SYSTEMS MOUNTED TO BUILDING STRUCTURES

INTRODUCTION

B1 Scope 74
 B2 Glossary 74

CONSTRUCTION

B3 General 74

B4 Flammability of Materials 74

PERFORMANCE

B5 Mechanical Tests 75
 B5.1 Mold stress test 75
 B5.2 Adhesive test 75
 B5.3 Mounting securement test 75
B6 Common Building Materials and Building Surface Arrangements 76

MARKINGS AND INSTALLATION INSTRUCTIONS

B7 Details 77
B8 Installation Instructions 77

ULNORM.COM : Click to view the full PDF of UL 1286 2022

INTRODUCTION

1 Scope

1.1 These requirements cover office furnishing panels, study carrels, work stations, and pedestal-style systems that form an office furnishing system in accordance with the National Electrical Code, ANSI/NFPA 70. These are able to be provided with an electrical distribution system, including switches, convenience outlets, and channels for routing communication cables within system components separate from electrical raceways. Office furnishing systems include filing cabinets, desks, work surfaces, shelves, storage units, and similar items that have a particular electrical or mechanical function unique to an office furnishing system.

1.2 These requirements also cover lighting units intended to be mechanically attached to particular components within an individual device or office furnishing system.

1.3 These requirements also cover modular pre-wired office furnishing wiring systems.

1.4 These requirements do not cover panels that are intended to penetrate the ceiling, or that are used to support the building structure.

1.5 These requirements also cover office furnishing systems intended for mounting to building structures for stability or support.

1.6 Individual commercial office furnishings are covered by UL 2999. These products may include, but are not limited to:

- a) Desks;
- b) Tables;
- c) Conference room tables;
- d) Bookcases;
- e) Storage cabinets; and
- f) Motorized carts and stands for audio/video equipment; and
- g) Benching Systems.

The above products may be provided with modesty and privacy screens.

2 Glossary

2.1 For the purposes of this Standard the following definitions apply.

2.2 **ACCESSIBLE PART** – A part located so that it is capable of being contacted by a person, either directly or as determined using the probe illustrated in [Figure 9.1](#).

2.3 **ACCESSORY** – An electrical component that is intended to be attached in the field or to be shipped separately; for example, a raceway, a top- or base-feed, a fixture, or similar component.

2.4 **BRANCH CIRCUIT** – The circuit conductors between the final overcurrent device protecting the circuit and the outlet(s).

2.5 **BRANCH CIRCUIT, MULTIWIRE** – A branch circuit that consists of two or more ungrounded conductors that have a voltage between them, and a grounded conductor that has equal voltage between it and each ungrounded conductor of the circuit and that is connected to the neutral or grounded conductor of the system.

2.6 **CHANNEL** – A passage intended for the routing and holding of communication wiring, low-voltage wiring, and wiring having functional insulation plus a layer of supplementary insulation. A channel is not required to provide mechanical protection, and is not evaluated as a raceway.

2.7 **CLASS 2 CIRCUIT** – A circuit having power and voltage limitations as defined in ANSI/NFPA 70, Article 725. To determine whether a circuit is within Class 2 limits, measurements shall be made in accordance with UL 5085-1 and UL 5085-3, or UL 1310.

2.8 **CONNECTOR, UNIT-TO-UNIT MECHANICAL** – An assembly that is used to connect two or more adjacent units for the purpose of providing mechanical support between the units.

2.9 **CORD CONNECTOR (convenience outlet)** – A female contact device that is wired or molded on flexible cord and intended to be installed as part of an office furnishing wiring system to supply current to utilization equipment.

2.10 **CONVENIENCE OUTLET** – A female connector of one of the configurations covered in the Standard for Wiring Devices – Dimensional Requirements, ANSI/NEMA WD6 that is provided for the connection of a small appliance, a work light, or similar product.

2.11 **CORE** – That portion of an office furnishing structural unit from one outside surface to its opposite outside surface, excluding decorative trim, electrical hardware, and mechanical supporting feet or glides.

2.12 **ELECTRICAL CONNECTING ASSEMBLY TYPES:**

BASE FEED – An electrical raceway assembly that contains supply conductors used to provide electrical power from a branch-circuit electrical supply located in the floor, column or wall of the building structure to the base of the office furnishing starter unit.

PASS-THROUGH UNIT – An electrical raceway assembly without any means for connection of utilization equipment. Used to pass electrical power through a unit.

TOP FEED – An electrical raceway assembly that contains the electrical supply conductors used to provide electrical power from a branch-circuit electrical supply located in the ceiling or wall of the building structure to the office furnishing starter unit.

UNIT-TO-UNIT – An electrical raceway assembly that is used to electrically interconnect two adjacent mechanically connected units.

SYSTEMS JUMPER – An electrical raceway connection assembly that is used for the interconnection of office furnishing electrical systems and manufactured wiring systems.

SYSTEM-TO-SYSTEM ADAPTER – An electrical raceway connection assembly that is used for the interconnection of one type or configuration of office furnishing electrical system to a different type or configuration of office furnishing electrical system.

2.13 **ENCLOSURE** – A part of the equipment that:

a) Renders inaccessible all or any parts of the equipment that may otherwise present a risk of electric shock;

b) Retards propagation of flame initiated by electrical disturbances occurring within; and

c) Provides the internal components with protection from outside physical abuses.

2.14 FABRIC PARTITIONS – A partition consisting of fabric without a rigid backing that is attached to a framing system.

2.15 FIELD-WIRING TERMINAL – A terminal to which a conductor is intended to be connected in the field.

2.16 FUNCTIONAL LOAD^a – The level of loading or force typical of hard use.

2.17 FURNISHING SYSTEM – An arrangement of interconnected or individual units, work stations, study carrels, and similar types of products. A furnishing system is defined as being of one of the following three types:

Type I – A system that provides all required parts and employs prewired modular raceways and accessories requiring only quick connect and disconnect means for electrical connections, other than the permanent connection to the branch-circuit supply. A Type I system is not prohibited from being shipped with accessories:

a) Installed in the panel; or

b) Installed in the field when the accessories are marked for use in the system.

Type II – A system that provides raceways for the routing and termination of wiring in the field. Wiring assemblies, when provided, are not always complete. This type of system requires inspection of the wiring by the local authorities.

Type III – A system that is not intended to be wired and has no provision for the routing and termination of wiring.

2.18 INSULATION, BASIC – Insulation applied to live parts to provide basic protection against electric shock.

2.19 INSULATION, SUPPLEMENTARY – A separate layer of insulation that is provided in addition to the basic insulation to reduce the risk of electric shock in the event of breakdown of the basic insulation.

2.20 LOSS OF SERVICEABILITY^a – The failure of any component to carry its intended load or to perform its normal function or adjustments.

^a With the permission of BIFMA, this definition is reproduced from ANSI/BIFMA X 5.6. BIFMA shall not be responsible for the manner in which the information is presented, used, nor for any interpretations thereof.

2.21 OFFICE FURNISHING SYSTEM – System formed from office furnishing panels, study carrels, workstations, and pedestal-style systems, and the like. See [1.1](#), [1.2](#) and [1.5](#).

2.22 OFFICE FURNISHING UNIT – A combination of panels that create one office area. An office furnishing system is made up of one or more office furnishing units.

2.23 PANEL^a – A flat or curved surface that controls and/or defines space; provides privacy and a means for hanging components.

2.24 PANEL MOUNTED COMPONENT^a – A product intended to be supported wholly by a panel system.

2.25 PANEL RUN^a – Two or more panels connected in a straight line.

2.26 PANEL-SUPPORTED^a – Individually connected panels and work surface, filing, storage, and shelving components and accessories that receive their primary support from the panels and that, when combined, form complete workstations.

2.27 PANEL SYSTEMS PRODUCTS^a – The panels, screens, and various panel-mounted components used in conjunction with panel systems.

2.28 PROOF LOAD^a – The level of loading or force in excess of hard use.

2.29 RACEWAY – A completely enclosed channel intended specifically for the holding and routing of system wiring, where the conductors of electric light and power systems are separate from the conductors of Class 2 circuit systems. A raceway provides mechanical protection to the internal system wiring.

2.30 RACEWAY TYPES:

FURNISHING RACEWAY – A raceway that is physically supported by an office furnishing unit after installation or is integral to the office furnishing unit.

FURNISHING (PANEL) SUPPORTING RACEWAY – A raceway that the office furnishing unit rests directly upon or to which supporting feet or glides are mechanically connected. See [Figure 2.1](#).

PASS-THROUGH FURNISHING RACEWAY – A raceway that is physically connected between other raceways that does not have convenience outlets or any other means for connection of utilization equipment and is used to pass electrical power through a unit.

2.31 RACEWAY, FURNISHING-SUPPORTING – A raceway that the furnishing rests directly upon, or to which supporting feet or glides are mechanically connected. See [Figure 2.1](#).

ULNORM.COM : Click to view the full text of UL 1286 2022

Figure 2.1
Furnishing-Supporting Raceway

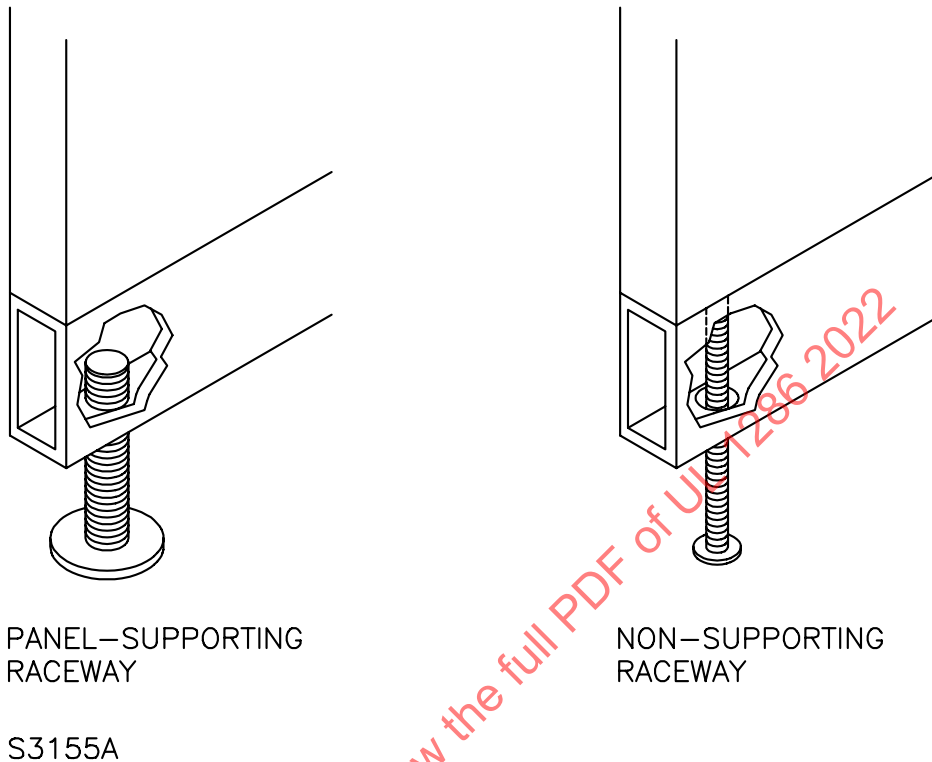

2.32 RECEPTACLE, CONVENIENCE (convenience outlet) – A female contact device intended to be installed as part of an office furnishing wiring system to supply current to utilization equipment.

2.33 SCREEN^a – Non-load-carrying space divider that is less than ceiling height.

2.34 STARTER UNIT – The unit that is connected to the external supply source and that sometimes has provision for electrical connection of additional portions of an office furnishing system. The physical location of the starter unit within the system is not specified, however, a series of electrically interconnected units forming a wall has a single starter unit.

2.35 STARTER UNIT TYPES:

FIXED STARTER UNIT – A unit that is intended for permanent attachment to the building structure. A unit is permanently attached when the unit is secured and supported by mechanical fastening to the building structure. A bracket or similar arrangement that has no positive fastening means, such as a bolt or screw, to secure the unit is not permanent attachment, nor is an arrangement that serves only to stabilize the unit.

FREESTANDING STARTER UNIT – A unit that is not intended for permanent attachment to the building structure and is not provided with means for such attachment.

2.36 SURFACE CLASSIFICATIONS^a:

ADJUSTABLE KEYBOARD SURFACE – An adjustable surface that is intended for placement of the keyboard, and/or other computer input devices.

DISPLAY SHELF – A shelf with a sloping surface and retaining flange or edge.

PRIMARY SURFACE – A surface that has the apparent potential for the highest loading within a workstation or a surface on which a person may sit. In cases where more than one horizontal surface exists, there may be more than one primary surface.

SECONDARY SURFACE – A surface that is used for storage (i.e., a shelf) or occupied exclusively by the equipment placed on the surface.

TRANSACTION SURFACE – A surface that is less than 16 in (406 mm) deep and is not enclosed. It is primarily used as a temporary work surface and not as a shelf.

WRITING SHELF – A moveable, typically stowable surface that is not intended to carry loads greater than 25 lb (11 kg), whose primary function is to support ancillary office tasks, such as writing and short-term reference material handling.

2.37 TEST LOAD^a – A particular load/force placed in or on a component specified by a test procedure and not included in the dead weight of the component.

2.38 TIP OVER^a – The condition where the unrestricted unit will not return to its normal upright position.

2.39 UNIT – A panel, table, storage cabinet, file cabinet or the like, the primary purpose of which is to form an office furnishing system or a portion of a system.

2.40 UNIT INSERT – A separable portion of a panel (excluding decorative trim, electrical components, and structural elements of the unit) that is intended to be removed or replaced in the field, with or without the use of tools.

2.41 USER SERVICING – Any form of servicing that is intended to be performed by personnel other than qualified service personnel. Some examples of user servicing are:

- a) The attachment of accessories by means of attachment plugs, convenience outlets, or by means of other separable connections.
- b) The replacement of:
 - 1) Fuses and lamps that are accessible without the use of tools, and
 - 2) Lamps such as those employed for ambient lighting and that require frequent replacement, whether or not the operation requires the use of tools.
- c) The disconnection or connection of a unit, excluding a permanently connected starter unit, constructed so that the user is not exposed to basic insulated or uninsulated live parts.
- d) The laying in of communication-type cables or telephone cord in a cord-management trough or a designated communication channel.

2.42 USER ADJUSTABLE SURFACES^a – A surface that is intended to be adjusted by the user while under normal use.

2.43 VIDEO MOUNTING SYSTEM TYPES:

ADJUSTABLE MOUNT – A mounting system designed with components that may be adjusted once, infrequently or requires a tool be used for adjustment and is intended to support the video display in a fixed position after assembly and installation.