



UL 1082

STANDARD FOR SAFETY

Household Electric Coffee Makers and
Brewing-Type Appliances

ULNORM.COM : Click to view the full PDF of UL 1082 2024

ULNORM.COM : Click to view the full PDF of UL 1082 2024

UL Standard for Safety for Household Electric Coffee Makers and Brewing-Type Appliances, UL 1082
Sixth Edition, Dated March 17, 2009

Summary of Topics

This revision of ANSI/UL 1082 dated July 10, 2024 includes the following changes in requirements:

- Adding DC voltage as output of equipment for Dielectric Voltage-Withstand; [51.1](#), [51.7](#)***
- Revisions to references to UL 4200A to Update Standard Title and Reference to Supplement SB Products Based on Reese's Law; [26.10](#)***

Text that has been changed in any manner or impacted by ULSE's electronic publishing system is marked with a vertical line in the margin.

The revised requirements are substantially in accordance with Proposal(s) on this subject dated May 31, 2024.

All rights reserved. No part of this publication may be reproduced, stored in a retrieval system, or transmitted in any form by any means, electronic, mechanical photocopying, recording, or otherwise without prior permission of ULSE Inc. (ULSE).

ULSE provides this Standard "as is" without warranty of any kind, either expressed or implied, including but not limited to, the implied warranties of merchantability or fitness for any purpose.

In no event will ULSE be liable for any special, incidental, consequential, indirect or similar damages, including loss of profits, lost savings, loss of data, or any other damages arising out of the use of or the inability to use this Standard, even if ULSE or an authorized ULSE representative has been advised of the possibility of such damage. In no event shall ULSE's liability for any damage ever exceed the price paid for this Standard, regardless of the form of the claim.

Users of the electronic versions of UL's Standards for Safety agree to defend, indemnify, and hold ULSE harmless from and against any loss, expense, liability, damage, claim, or judgment (including reasonable attorney's fees) resulting from any error or deviation introduced while purchaser is storing an electronic Standard on the purchaser's computer system.

No Text on This Page

ULNORM.COM : Click to view the full PDF of UL 1082 2024

MARCH 17, 2009
(Title Page Reprinted: July 10, 2024)



ANSI/UL 1082-2024

1

UL 1082

Standard for Household Electric Coffee Makers and Brewing-Type

Appliances

First Edition – December, 1972
Second Edition – July, 1979
Third Edition – August, 1985
Fourth Edition – October, 1991
Fifth Edition – November, 1996

Sixth Edition

March 17, 2009

This ANSI/UL Standard for Safety consists of the Sixth Edition including revisions through July 10, 2024.

The most recent designation of ANSI/UL 1082 as an American National Standard (ANSI) occurred on July 10, 2024. ANSI approval for a standard does not include the Cover Page, Transmittal Pages, and Title Page.

The Department of Defense (DoD) has adopted UL 1082 on February 6, 1976. The publication of revised pages or a new edition of this Standard will not invalidate the DoD adoption.

Comments or proposals for revisions on any part of the Standard may be submitted to ULSE at any time. Proposals should be submitted via a Proposal Request in ULSE's Collaborative Standards Development System (CSDS) at <https://csds.ul.com>.

Our Standards for Safety are copyrighted by ULSE Inc. Neither a printed nor electronic copy of a Standard should be altered in any way. All of our Standards and all copyrights, ownerships, and rights regarding those Standards shall remain the sole and exclusive property of ULSE Inc.

© 2024 ULSE Inc. All rights reserved.

No Text on This Page

ULNORM.COM : Click to view the full PDF of UL 1082 2024

CONTENTS

INTRODUCTION

1	Scope	7
2	Components	7
3	Undated References	7
4	Units of Measurement	7
5	Glossary.....	7

CONSTRUCTION

6	General	10
7	Frame and Enclosure	11
8	Assembly	17
9	Handles.....	18
	9.1 General	18
	9.2 Handle assembly.....	19
10	Corrosion Protection.....	20
11	Supply Connections.....	20
	11.1 General.....	20
	11.2 Strain relief.....	23
	11.3 Pin terminals	23
	11.4 Bushings	25
12	Current-Carrying Parts.....	26
13	Internal Wiring.....	26
	13.1 General.....	26
	13.2 Protection of wiring	27
	13.3 Splices.....	27
14	Secondary Circuits	28
	14.1 General.....	28
	14.2 Limited-energy secondary circuits	29
15	Heating Elements.....	29
16	Electrical Insulation.....	30
	16.7 Film-coated wire (magnet wire)	31
17	Thermal Insulation.....	31
18	Thermal Cutoffs	31
19	Lampholders.....	32
20	Switches.....	32
21	Dual Voltage Appliance.....	33
22	Controls and Control Circuits.....	33
22A	Electromechanical and Electronic Controls	34
22B	Controls – End Product Test Parameters.....	34
	22B.1 General	34
	22B.2 Auxiliary controls	35
	22B.3 Operating controls (regulating controls).....	35
	22B.4 Protective controls (limiting controls).....	36
	22B.5 Controls using a temperature sensing device.....	38
22C	Capsule-Type Brewing Appliance Controls	38
	22C.1 General	38
	22C.2 Temperature regulating.....	38
	22C.3 Limiting-type devices	39
23	Overheating Protection	39
24	Spacings	40
	24.1 General.....	40

24.2	Barriers.....	41
24A	Spacings on Printed-Wiring Boards	41
25	Grounding	42
26	Protection Against Injury to Persons	42
26A	Ground-Fault, Arc-Fault, and Leakage Current Detectors/Interrupters	44
26B	Surge Protective Device	44
27	Pressure Vessels and Parts Subject to Pressure.....	44

PERFORMANCE

28	General	46
29	Resistance of Grounding Test.....	46
30	Power Input	46
31	Leakage Current Test	46
32	Operational Tests	48
33	Normal Temperature Tests	49
	33.1 General.....	49
	33.2 Specific test conditions.....	56
34	Leakage Current as a Result of Moisture Tests	57
35	Dielectric Voltage-Withstand Test	59
36	Broken Element Test	60
37	Strain Relief Test.....	60
38	Push-Back Relief Test.....	61
39	Metal Enclosure Impact Tests.....	61
40	Thermal Degradation.....	64
41	Handle Securement Tests	65
	41.1 General.....	65
	41.2 Oven conditioning.....	65
	41.3 Dishwashing.....	65
	41.4 Flexing test	65
	41.5 Static load	66
	41.6 Static force.....	66
	41.7 Dynamic load	69
42	Under-Cabinet and Wall Mounted Appliances-Impact Test.....	69
43	Loading Test	69
44	Stability Test	70
45	Tip Over Test	70
46	Dynamic Stability Test.....	70
46A	Hydrostatic Pressure Tests for Parts Subject to Pressure	73
46B	Open Brew Chamber Test – Pressure Brewing Appliances.....	74
46C	Brew Chamber Blockage Following Mold Stress Test for Capsule-Type Brewing Appliances.....	74
47	Abnormal Operation Tests.....	74
	47.1 General.....	74
	47.2 Specific test conditions.....	76
	47.3 Dual voltage appliances	78
	47.4 Fusible devices test	79
	47.5 Surge test	79
	47.6 Pressure brewing appliances.....	80
	47.7 Abnormal operation reused sealed capsule test	81
48	Component Failure Test.....	81
49	Automatic Controls Test	82
	49.1 General.....	82
	49.2 Endurance	82
50	Permanence of Marking Tests	83

MANUFACTURING AND PRODUCTION-LINE TESTS

51 Dielectric Voltage-Withstand Test 84
 51A Insertion/Withdrawal Test for Electric Kettles 86
 52 Polarization and Grounding Continuity Tests..... 86
 52.1 Polarization test..... 86
 52.2 Continuity of grounding connection 86
 52.3 Electrical indicating device..... 86

RATINGS

53 Details 87

MARKINGS

54 Details 87
 55 Carton Marking 89

INSTRUCTION MANUAL

56 General 90
 57 All Appliances 91
 58 Specific Appliances 91
 59 User Maintenance 92

SUPPLEMENT SA – HOUSEHOLD ELECTRIC DRIP-TYPE COFFEE MAKERS AND SIMILAR DRIP-TYPE BREWING APPLIANCES

SA1 Scope 95
 SA2 Glossary 95
 SA3 Assembly 95
 SA4 Corrosion Protection 95
 SA5 Supply Connections 95
 SA6 Gaskets and Seals 96
 SA7 Water Connections 96
 SA8 Thermal Conductivity 97
 SA9 Grounding 97
 SA10 Operating Controls 97
 SA11 Power-On Indicator 98
 SA12 Temperature Controls 98
 SA12.1 General 98
 SA12.2 Temperature regulating 99
 SA12.3 Limiting-type devices 99
 SA13 Operation Degradation 100
 SA14 Leakage Current 101
 SA15 Normal Temperature 101
 SA16 Leakage Current as a Result of Moisture 102
 SA17 Stability 103
 SA18 Loading Test 103
 SA19 Impact Test 103
 SA20 Abnormal Operation 104
 SA20.1 General 104
 SA20.2 Specific test conditions 104
 SA20.3 Dry operation 104
 SA20.4 Overfill 105

SA20.5	Restricted water inlet	106
SA21	Tests by Manufacturer	106
SA21.1	Polarization verification	106
SA21.2	Continuity of grounding connection	107
SA21.3	Indicator	107
SA22	Markings	107
SA23	Graphical Symbols and Supplemental Markings	107
SA23.1	No user-serviceable parts compartment warning	107
SA23.2	Graphical symbol size and color	109
SA23.3	Supplemental marking size and color	109
SA23.4	Size of outlines and symbols	110
SA23.5	Explanation of graphical symbols in the operating instructions	110
SA24	Important Safeguards	111
SA25	User Maintenance	112

SUPPLEMENT SB – HOSPITALITY-USE APPLIANCES

SB1	Scope	115
SB2	Assembly	115
SB3	Supply Connections	115
SB4	Grounding	116
SB5	Operating Controls	116
SB6	Power-On Indicator	117
SB7	Operation Tests	117
SB8	Test for Permanence of Cord Tag	117
SB9	Tests by Manufacturer – Continuity of Grounding Connection	118
SB10	Markings	118
SB11	Important Safeguards Cord Tag	119
SB12	User Maintenance	119

SUPPLEMENT SC – SAFETY OF SMART ENABLED HOUSEHOLD ELECTRIC COFFEE MAKERS AND BREWING-TYPE APPLIANCES

SC1	Scope	121
SC2	Construction – General	122
SC2.1	Controls	122
SC2.2	Separation of Circuits	122
SC2.3	Communication and Display Devices	122
SC2.4	Communication Conductors and Cables	123
SC2.5	Communication Connectors	123
SC2.6	Smart Enabled or Remote Operation	123
SC3	Functional Safety	123
SC4	Resistance to Electro-Magnetic Phenomena (Immunity)	124
SC5	Markings and Instructions	124

Appendix A

INTRODUCTION

1 Scope

1.1 These requirements cover portable electric coffee makers, percolators, coffee urns, and other brewing-type appliances rated 120 V or less, for use in ordinary locations in accordance with the National Electrical Code, NFPA 70.

1.2 In addition to coffee makers, this Standard covers tea pots, water kettles, carafes, soup warmers, and other similar appliances in which liquid is heated to greater than 115°F (46°C), and are lifted and tilted to dispense the liquid in normal service.

1.3 These requirements do not cover coffee-making-type appliances with capacities of more than 250 ounces (7.4 L), appliances intended for outdoor use, or appliances that are covered in individual requirements that are separate from this Standard.

1.4 For the purposes of this Standard, a requirement that applies to one type of equipment is identified by a specific reference to the type of equipment involved (for example, percolator or other specific appliance). In the absence of such specific reference or if the term "appliance" is employed, it is to be understood that the requirement applies to all types of equipment covered by the Standard.

2 Components

Section 2 deleted

3 Undated References

3.1 Any undated reference to a code or standard appearing in the requirements of this standard shall be interpreted as referring to the latest edition of that code or standard.

4 Units of Measurement

4.1 Values stated without parentheses are the requirement. Values in parentheses are explanatory or approximate information.

4.2 Unless indicated otherwise all voltages and current values mentioned in this Standard are root-mean-square (rms).

5 Glossary

5.1 For the purposes of this Standard the following definitions apply.

5.1.1 **APPLIANCE COUPLER** – A single-outlet, female contact device for attachment to a flexible cord as part of a detachable power-supply cord to be connected to an appliance inlet (motor attachment plug).

5.1.2 **APPLIANCE INLET (Motor Attachment Plug)** – A male contact device mounted on an end product appliance to provide an integral blade configuration for the connection of an appliance coupler or cord connector.

5.1.3 **APPLIANCE (FLATIRON) PLUG** – An appliance coupler type of device having a cord guard and a slot configuration specified for use with heating or cooking appliances.

5.1.3.1 CAPSULE-TYPE BREWING APPLIANCE – An appliance intended to be used with open capsules or sealed capsules.

5.1.4 COMPONENT – A device or fabricated part of the appliance covered by the scope of a safety standard dedicated to the purpose. When incorporated in an appliance, equipment otherwise typically field installed (e.g. luminaire) is considered to be a component. Unless otherwise specified, materials that compose a device or fabricated part, such as thermoplastic or copper, are not considered components.

5.1.5 CONTROL, AUTOMATIC ACTION – A control in which at least one aspect is non-manual.

5.1.6 CONTROL, AUXILIARY – A device or assembly of devices that provides a functional utility, is not relied upon as an operational or protective control, and therefore is not relied upon for safety. For example, an efficiency control not relied upon to reduce the risk of electric shock, fire, or injury to persons during normal or abnormal operation of the end product is considered an auxiliary control.

5.1.7 CONTROL, MANUAL – A device that requires direct human interaction to activate or rest the control.

5.1.8 CONTROL, OPERATING – A device or assembly of devices, the operation of which starts or regulates the end product during normal operation. For example, a thermostat, the failure of which a thermal cutout/limiter or another layer of protection would reduce the risk of electric shock, fire, or injury to persons, is considered an operating control.

5.1.9 CONTROL, PROTECTIVE – A device or assembly of devices, the operation of which is intended to reduce the risk of electric shock, fire or injury to persons during normal and reasonably anticipated abnormal operation of the appliance. For example, a thermal cutout/limiter, or any other control/circuit relied upon for normal and abnormal conditions, is considered a protective control. (During the testing of the protective control/circuit, the protective functions are verified under normal and single-fault conditions of the control.)

5.1.10 CONTROL, TYPE 1 ACTION – The actuation of an automatic control for which the manufacturing deviation and the drift (tolerance before and after certain conditions) of its operating value, operating time, or operating sequence has not been declared and tested under this standard.

5.1.11 CONTROL, TYPE 2 ACTION – The actuation of an automatic control for which the manufacturing deviation and the drift (tolerance before and after certain conditions) of its operating value, operating time, or operating sequence have been declared and tested under this standard.

5.1.12 CORD CONNECTOR – A female contact device wired on flexible cord for use as an extension from an outlet to make a detachable electrical connection to an attachment plug or, as an appliance coupler, to an equipment inlet.

5.1.13 CORDLESS KETTLE – Kettle which is connected to the electricity supply only when placed on the base provided with it.

5.1.14 ELECTRONIC CIRCUIT – Circuit incorporating at least one electronic component. Parts of the circuit may also be used for functional purposes.^a

^a ©IEC. This material is reproduced from IEC 60335-1 Ed. 5.0 b:2010 with permission of the American National Standards Institute (ANSI) on behalf of the International Electrotechnical Commission. All rights reserved.

5.1.15 ELECTRONIC COMPONENT – Part in which conduction is achieved principally by electrons moving through a vacuum, gas, or semiconductor. Neon indicators are not considered to be electronic components.^a

^a ©IEC. This material is reproduced from IEC 60335-1 Ed. 5.0 b:2010 with permission of the American National Standards Institute (ANSI) on behalf of the International Electrotechnical Commission. All rights reserved.

5.2 LINE-VOLTAGE CIRCUIT – A circuit involving a potential of not more than 120 volts, and having circuit characteristics in excess of those of a low-voltage or an isolated-limited secondary circuit.

5.3 LOW-VOLTAGE (SECONDARY) CIRCUIT – A circuit involving a potential of not more than 30 volts alternating-current, (42.4 volt peak or direct-current), and supplied by an isolating transformer. A circuit derived from a source of supply classified as a line voltage circuit, using impedance in series with the supply circuit as a means of limiting the voltage and current, is not considered to be a low voltage nor an isolated limited-energy secondary circuit. See [14.2.1](#).

5.3.1 OFF POSITION – Stable position of a switching device in which the circuit controlled by the switch is disconnected from its supply or, for electronic disconnection, the circuit is de-energized. Off position does not imply an all-pole disconnection.^a

^a ©IEC. This material is reproduced from IEC 60335-1 Ed. 5.0 b:2010 with permission of the American National Standards Institute (ANSI) on behalf of the International Electrotechnical Commission. All rights reserved.

5.3.1.1 OPEN CAPSULE – A capsule that is able to receive the brewing media or provides a permeable container for brewing media that can operate in a pressure brewing appliance.

5.3.1.2 PRESSURE BREWING APPLIANCE – A heated appliance intended to make a brewed beverage such as coffee or tea, and with a water reservoir separate from the brewed beverage container; the brewed beverage container is not required to be provided with the appliance. A pressure brewing appliance has either an integrated sealed brewing chamber or is capable of using a sealed capsule as brewing material.

5.3.2 PROTECTIVE ELECTRONIC CIRCUIT – An electronic circuit which is intended to reduce the risk of electric shock, fire, or injury to persons during normal and reasonable anticipated abnormal operation of the appliance.

5.3.3 PUMP – A device which has as its primary function to move fluid by mechanical action.

5.3.4 SEALED CAPSULE – Prepackaged brewing media in a non-permeable container that must be punctured for brewing.

5.4 TEMPERATURE-LIMITING THERMOSTAT – A thermostat which functions only under conditions which produce abnormal temperatures. The malfunction of such a thermostat might or might not result in a risk of fire.

5.5 TEMPERATURE-REGULATING THERMOSTAT – A thermostat which functions only to regulate the temperature of the appliance under normal conditions of use, and whose malfunction does not result in a risk of fire.

5.6 TEMPERATURE-REGULATING AND -LIMITING THERMOSTAT – A thermostat which functions to regulate the temperature of the heating appliance under normal conditions of use, and also serves to prevent a risk of fire which might result from conditions of abnormal operation of the appliance.

5.7 THERMOSTAT – A temperature-sensing device or system, the operating temperature of which may be either fixed or adjustable, and which keeps the temperature of the controlled part between certain limits by automatically opening and/or closing a circuit.

CONSTRUCTION

6 General

6.1 Only materials that are acceptable for the particular use shall be used in an appliance. An appliance shall be made and finished with the degree of uniformity and grade of workmanship practicable in a well-equipped factory.

6.2 A component of a product covered by this Standard shall:

- a) Comply with the requirements for that component as indicated in the individual section covering that component;
- b) Be used in accordance with its rating established for the intended conditions of use;
- c) Be used within its established use limitations or conditions of acceptability;
- d) Additionally comply with the applicable requirements of this end product Standard; and
- e) Not contain mercury, unless used within a fluorescent, high intensity discharge, or neon lamp bulb.

Exception No. 1: A component of a product covered by this Standard is not required to comply with a specific component requirement that:

- a) Involves a feature or characteristic not required in the application of the component in the product;*
- b) Is superseded by a requirement in this Standard; or*
- c) Is separately investigated when forming part of another component, provided the component is used within its established ratings and limitations.*

Exception No. 2: A component complying with a component standard other than those cited in this Standard is acceptable if:

- a) The component also complies with the applicable component standard indicated in this Standard; or*
- b) The component standard:*
 - 1) Is compatible with the ampacity and overcurrent protection requirements in the National Electrical Code, NFPA 70, where appropriate;*
 - 2) Considers long-term thermal properties of polymeric insulating materials in accordance with the Standard for Polymeric Materials – Long Term Property Evaluations, UL 746B; and*
 - 3) Any use limitations of the other component standard is identified and appropriately accommodated in the end use application. For example, a component used in a household application, but intended for industrial use and complying with the relevant component standard may assume user expertise not common in household applications.*

6.3 A component that is also intended to perform other functions, such as over current protection, ground-fault circuit-interruption, surge suppression, any other similar functions, or any combination thereof, shall comply additionally with the requirements of the applicable UL standard that cover devices that provide those functions.

Exception: Where these other functions are not required for the application and not identified as part of markings, instructions, or packaging for the appliance, the additional component standard need not be applied.

6.4 A component not anticipated by the requirements of this end product Standard, not specifically covered by the component standards noted in this Standard, and that involves a risk of fire, electric shock, or injury to persons, shall be additionally investigated in accordance with the applicable UL standard, and shall comply with [6.2](#) (b) – (e).

6.5 With regard to a component being additionally investigated, reference to construction and performance requirements in another UL end product standard is suitable where that standard anticipates normal and abnormal use conditions consistent with the application of this end product Standard.

7 Frame and Enclosure

7.1 The frame and enclosure of an appliance shall be strong and rigid enough to resist the abuses likely to be encountered during normal service. The degree of resistance inherent in the appliance shall preclude total or partial collapse with the attendant reduction of spacings, loosening or displacement of parts, and other serious defects that alone or in combination constitute an increase in the risk of fire, electric shock, or injury to persons.

7.2 An appliance shall be provided with an enclosure of material acceptable for the particular application. The enclosure shall house all electrical parts, except a supply cord, that may present a risk of fire, electric shock, or injury to persons under any conditions of use.

7.3 Among the factors that shall be considered when an enclosure is being judged for acceptability are its:

- a) Physical strength;
- b) Resistance to impact;
- c) Moisture-absorptive properties;
- d) Combustibility;
- e) Resistance to corrosion; and
- f) Resistance to distortion at temperatures to which the enclosure may be subjected under conditions of normal or abnormal use.

A nonmetallic enclosure shall comply with the enclosure requirements in the Standard for Polymeric Materials – Use in Electrical Equipment Evaluations, UL 746C. A metal enclosure or enclosure part shall be tested in accordance with Metal Enclosure Impact Tests, Section [39](#), for resistance to impact.

Exception No. 1: When considering the abnormal and severe conditions tests of UL 746C, the appliance enclosure is to be subjected to the Abnormal Operation Tests of Section [47](#).

Exception No. 2: Thermoset materials need not be subjected to the relative thermal capability requirements of UL 746C. For a thermoset material operating at a temperature above its temperature rating, the 1000 hour aging test specified in [40.1](#) shall be conducted.

Exception No. 3: An appliance employing a thermoplastic enclosure with a HB flammability rating is not required to comply with the flammability requirements of UL 746C if it complies with the requirements in [Table 7.1](#).

Table 7.1
Flammability requirements for enclosures

Flammability rating of enclosure material	Flammability requirements, additional testing, or both
V-0	<p>None</p> <p>1. 3/4 inch (19 mm) Flame Test (UL 746C)</p> <p>or</p> <p>1. Minimum 1/2 inch (12.7 mm) spacing from enclosure material (including ribs, grills, and the like) to any uninsulated live parts,</p> <p>2. HWI – Minimum 7 seconds (PLC-0,1,2,3,4), and</p> <p>3. HAI – Minimum 60 arcs (PLC-0,1)</p>
V-1	
V-2	
HB	

7.4 Cast- and sheet-metal portions of the enclosure shall be no thinner than indicated in [Table 7.2](#) unless the enclosure is found to be acceptable when judged under considerations such as mentioned in [7.3](#).

Table 7.2
Minimum acceptable thicknesses of enclosure metal

Metal	At small, flat, unreinforced surfaces and at surfaces that are reinforced by curving, ribbing and the like (or are otherwise of a shape and/or size) to provide equivalent physical strength		At relatively large unreinforced flat surfaces	
	Inches	(mm)	Inches	(mm)
Die-cast	3/64	(1.2)	5/64	(2.0)
Cast malleable iron	1/16	(1.6)	3/32	(2.4)
Other cast metal	3/32	(2.4)	1/8	(3.2)
Uncoated sheet steel	0.026 ^a	(0.66) ^a	0.026	(0.66)
Galvanized sheet steel	0.029 ^a	(0.74) ^a	0.029	(0.74)
Nonferrous sheet metal	0.036 ^a	(0.91) ^a	0.036	(0.91)

^a Thinner sheet metal may be employed if found to be acceptable when the enclosure is judged under considerations such as those mentioned in [7.3](#).

7.5 Electrical parts of an appliance shall be located or enclosed so that protection against unintentional contact with uninsulated live parts is provided.

7.6 For an appliance as mentioned in [47.2.6.4](#), the enclosure mentioned in [7.5](#) shall be provided with drainholes located below the lowest live part.

7.7 The enclosure shall be constructed so that molten metal, burning insulation, flaming particles, or the like does not fall on the supporting surface.

7.8 The requirement in [7.7](#) necessitates that an enclosure bottom with an opening be provided with a barrier above or below the opening if the opening is:

a) Under a motor unless:

1) The structural parts of the motor or of the appliance provide the equivalent of such a barrier;

2) The protection provided with the motor is such that no burning insulation or molten material falls to the surface that supports the appliance when the motor is energized under each of the following fault conditions:

- i) Open main winding;
- ii) Open starting winding;
- iii) Starting switch short-circuited; and
- iv) For a permanent-split-capacitor motor the capacitor is short circuited. The short circuit is to be applied before the motor is energized and the rotor is to be blocked.

3) The motor is provided with a thermal motor protector (a protective device that is sensitive to both temperature and current) that prevents the temperature of the motorwindings from becoming more than 125°C (257°F) under the maximum load under which the motor runs without causing the protector to cycle, and from becoming more than 150°C (302°F) with the rotor of the motor locked; or

4) The motor complies with the requirements for impedance-protected motors.

b) Under wiring, unless the wiring complies with the VW-1 (FR-1) flame test or the Vertical Flame Test described in the Reference Standard for Electrical Wires, Cables, and Flexible Cords, UL 1581.

c) Under an unenclosed switch, transformer, relay, solenoid, and the like, unless it can be shown that malfunction of the component is not likely to result in a fire.

d) Under field- and factory-made splices and overload and overcurrent protective devices.

Exception: A barrier need not be provided if the opening is not within the area under the component requiring a barrier as illustrated by Line D in [Figure 7.1](#).

7.9 The barrier mentioned in [7.8](#) shall be:

- a) Of metal, ceramic, or a material that would be acceptable as an enclosure in accordance with [7.3](#);
- b) Horizontal; and
- c) Located as indicated in [Figure 7.1](#), and shall not have an area less than that described in [Figure 7.1](#).

7.10 An opening in the enclosure that has a minor dimension of less than 1 inch (25.4 mm) is acceptable if a probe as illustrated in [Figure 7.2](#), inserted through the opening, cannot be made to touch any uninsulated live part of film-coated wire that involves the risk of electric shock. The probe shall be applied in all possible articulated positions before, during, and after insertion.

Figure 7.1
Location and extent of barrier

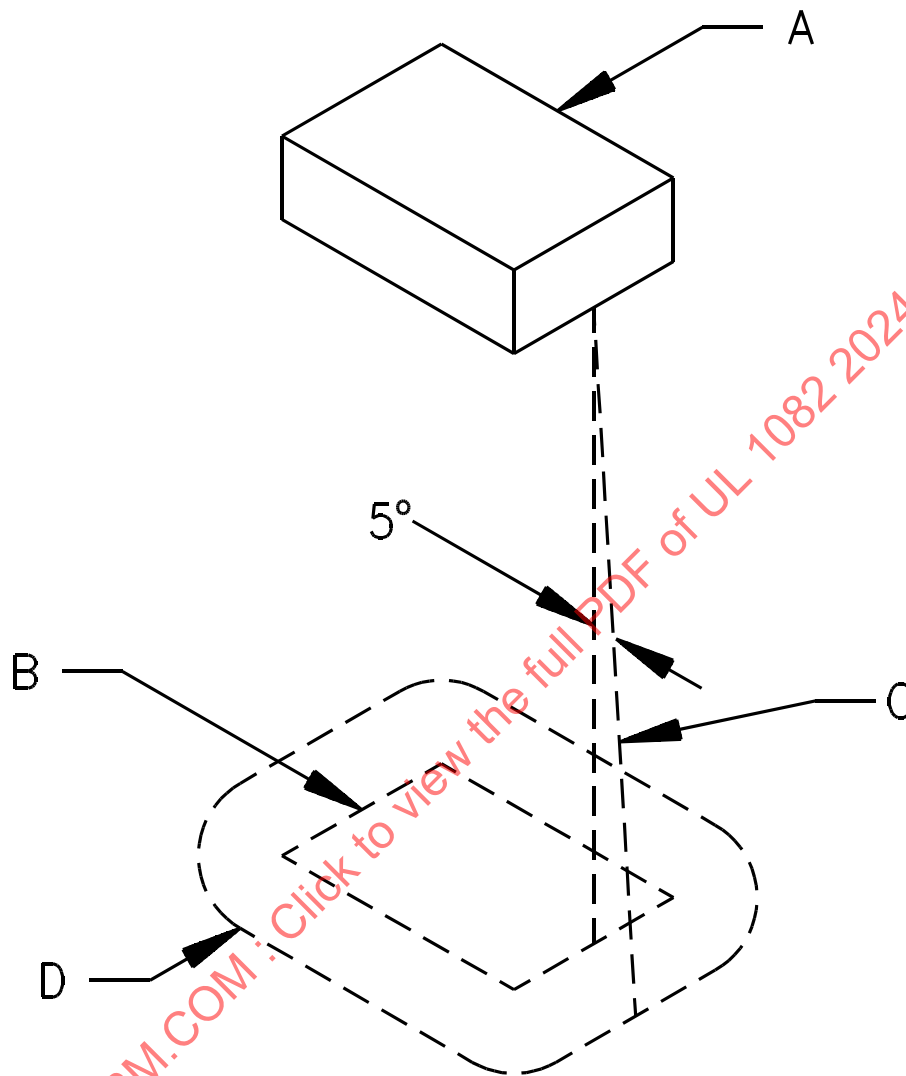

SA0604-1

A – Region to be shielded by barrier. This will consist of the entire component if it is not otherwise shielded and will consist of the unshielded portion of a component that is partially shielded by the component enclosure or equivalent.

B – Projection of outline of component on horizontal plane.

C – Inclined line that traces out minimum area of barrier. The line is always:

- 1) Tangent to the component;
- 2) 5 degrees from the vertical; and
- 3) So oriented that the area traced out on a horizontal plane is maximum.

D – Location (horizontal) and minimum area for barrier. The area is that included inside the line of intersection traced out by the inclined line C and the horizontal plane of the barrier.

Figure 7.2
Accessibility probe

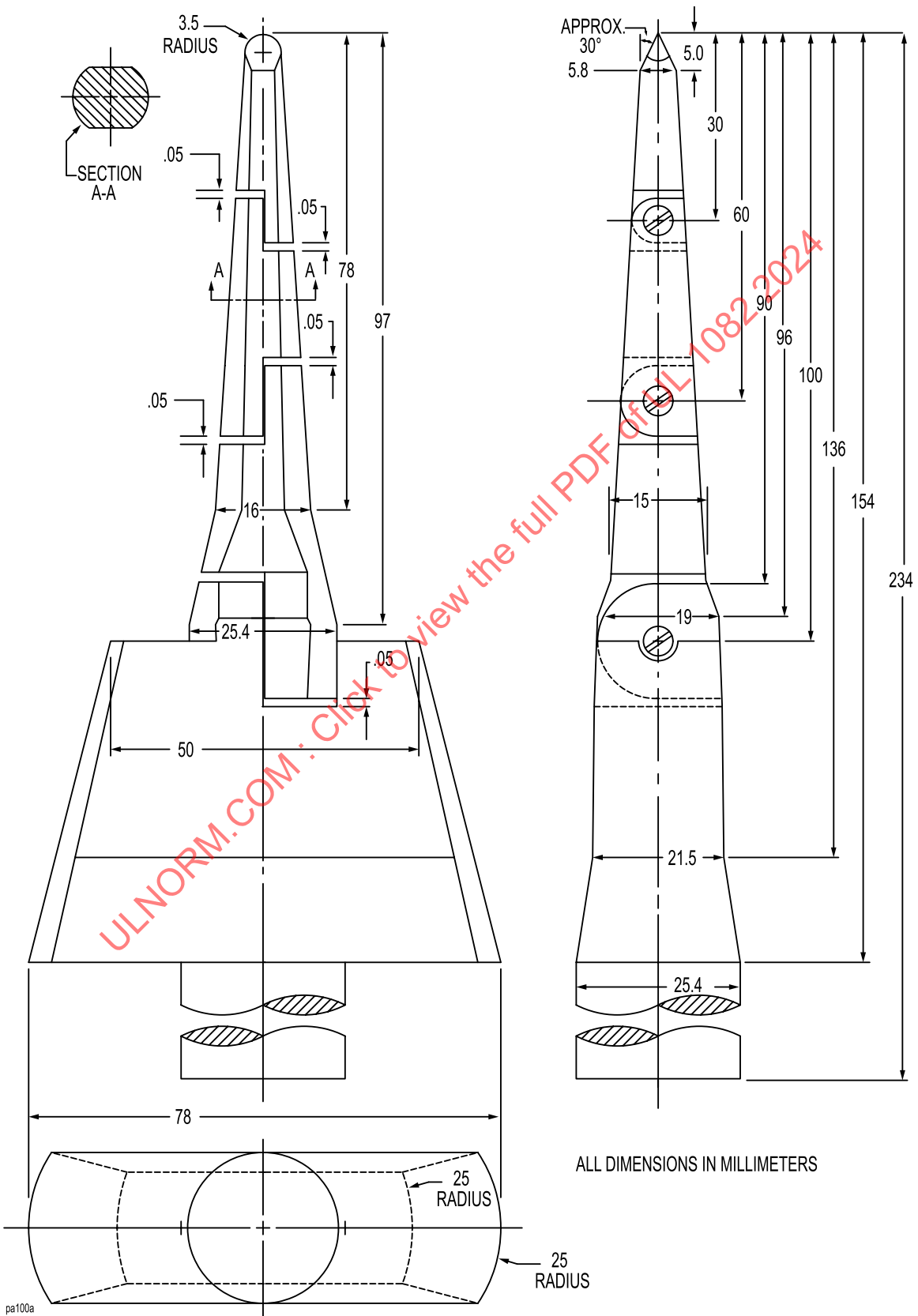
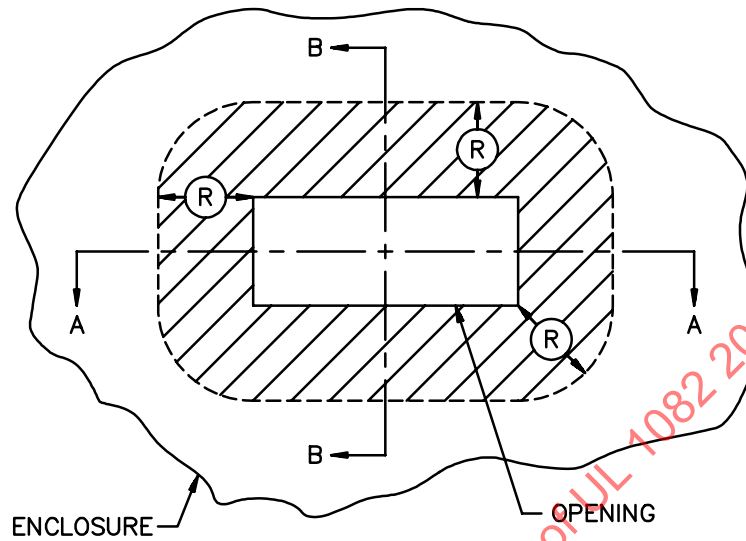
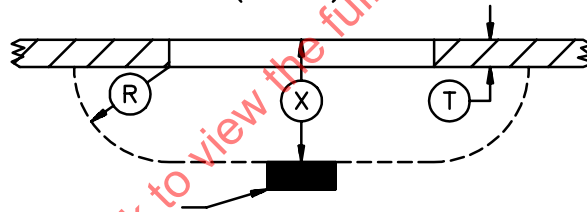

Figure 7.3
Opening in enclosure



SECTION A-A
($X=R+T$)



SECTION B-B
($X=R+T$)

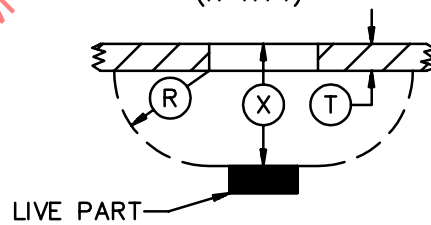

SB0610-1

7.11 An opening that has a minor dimension of 1 inch (25.4 mm) or more, in an enclosure, as illustrated in [Figure 7.3](#), is acceptable if, within the enclosure, there is no uninsulated live part or film-coated wire less than:

- a) R distance from the inside edge of the perimeter of the opening; and
- b) X distance from the plane of the opening.

T equals the enclosure thickness, R equals X minus T, and X equals 5 times the diameter of the largest round rod that can be inserted through the opening but not less than 6-1/16 inches (154 mm). In evaluating an opening, any barrier located within the volume is to be ignored unless it intersects the boundaries of the volume in a continuous, closed line.

7.12 If a marking draws attention of the user to a hole of any size in the enclosure for the adjustment of a thermostat or for a similar activity, it shall not be possible to damage insulation or contact uninsulated live parts through the hole with a 1/16-inch-diameter rod (1.6 mm).

7.13 During the examination of an appliance in connection with the requirements in [8.2](#) – [8.4](#), any part of the enclosure is to be disregarded – that is, it will not be assumed that the part in question affords protection against electric shock or injury to persons – if it either:

- a) Must be opened or removed, with or without the use of tools, to perform manufacturer's recommended user servicing, maintenance, operating adjustments, attachment of accessories, or other instructions; or
- b) Can be opened or removed without the use of tools.

Exception: A part that requires a tool for opening or removal to perform manufacturer's recommended user servicing, maintenance, operating adjustments, attachment of accessories, or other instructions is to remain in place if the appliance is marked in accordance with [54.6](#).

7.14 A component of an appliance that is likely to need inspection, replacement, cleaning, or other servicing shall be as accessible as possible. The component shall be readily accessible without the use of special tools (tools not available to other than service personnel) if it is intended to be manually operated or adjusted or periodically serviced.

7.15 The bulb and capillary tube of a thermostat shall be protected from mechanical damage if damage of the tube or bulb increases the risk of fire.

7.16 A part relied upon for compliance with this Standard, when fabricated from polymeric materials, shall have clear traceability as to composition, ingredients, and processing for the fabricated part to the extent that the composition, ingredients, or process impacts the compliance of the product. Fabricated parts complying with the Standard for Polymeric Materials – Fabricated Parts, UL 746D, meets this requirement.

8 Assembly

8.1 A switch, lampholder, or plug-type connector provided as a part of an appliance shall be mounted securely and prevented from turning by means other than friction between surfaces.

8.2 A lock washer properly applied is acceptable as a means to prevent turning of a stem-mounted switch.

8.3 Uninsulated live parts shall be secured to the base or surface so that they are prevented from turning or shifting in position as the result of stresses if such motion may result in a reduction of spacings below the minimum required in [24.1.1](#) and [24.1.2](#).

8.4 Friction between surfaces is not acceptable as a means to prevent shifting or turning of live parts, but a lock washer properly applied is acceptable.

9 Handles

9.1 *Relocated at 9.1.1*

9.2 *Relocated at 9.1.2*

9.3 *Relocated at 9.1.3*

9.4 *Relocated at 9.1.4*

9.5 *Relocated at 9.1.5*

9.6 *Relocated at 9.1.6*

9.7 *Relocated at 9.1.7*

9.1 General

9.1.1 Unless determined to be acceptable for the purpose, fastening of the vessel handle assembly of an appliance shall not rely on cement or equivalent materials alone. Mechanical means, such as pressure clamping, bosses and lances, and the like, shall be provided.

9.1.2 A handle assembly for a percolator, kettle, carafe, or other vessel used to lift, tilt, and hold a beverage shall be subjected to the requirements of Dynamic load, [41.7](#). This test is not to be applied to a percolator, kettle, carafe, or other hot liquid container vessel in which the handle and vessel (or vessel outer enclosure) are molded of one continuous material.

9.1.3 For an appliance or separate vessel that is provided with a webbed handle – that is a solid handle that cannot be grasped by wrapping the fingers around it – the web shall be a minimum of 1 inch in width and 3.25 inches in length. See [Figure 9.1](#).

Figure 9.1
Webbed handle

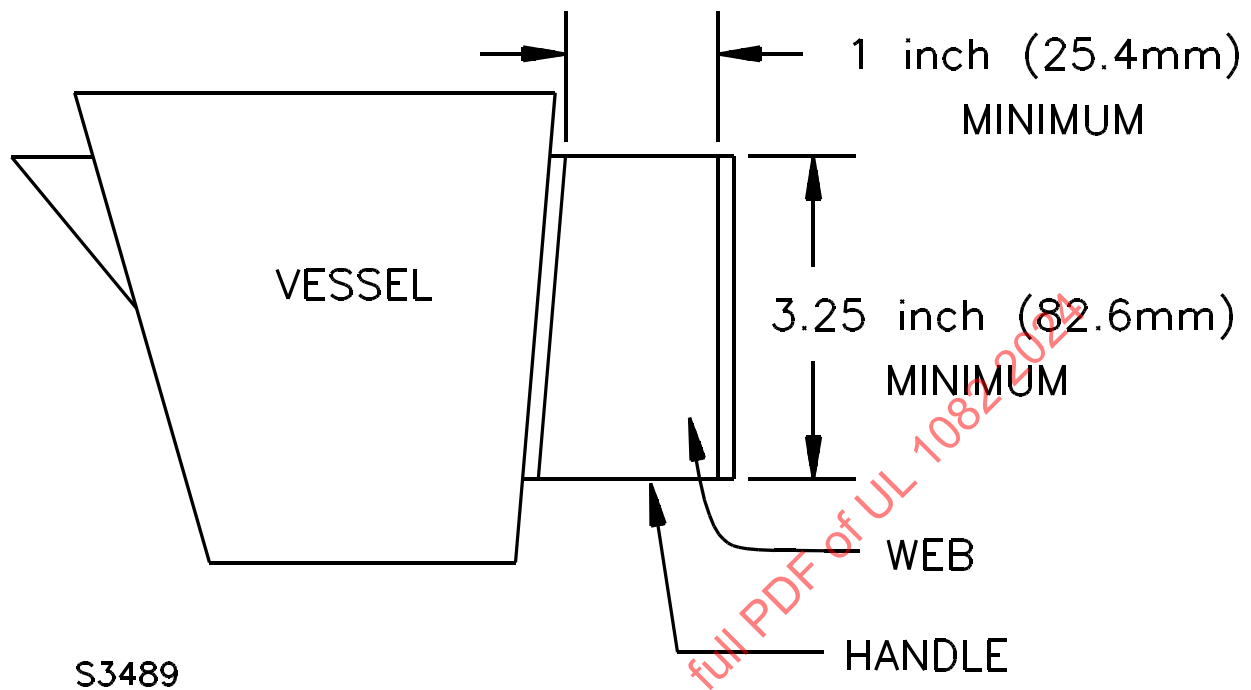

9.1.4 No portion of a nonmetallic handle whose failure could result in the loss of handle strength or integrity is to be subjected to a temperature in excess of the mechanical temperature index (without impact) of the material when tested as indicated in Normal Temperature Tests, Section [33](#).

9.1.5 On a vessel where handle securement is accomplished by a band around the body of the vessel, the diameter of the vessel above and below the band securement area shall be larger than the diameter at the area of securement. A handle shall be fastened so that a positive stop, interference screw, rivet, or other arrangement is provided so that with minor loosening, disengagement of the handle does not result.

Exception: The diameter of the vessel above and below the band securement need not be larger than the diameter at the area of securement if an equivalent means of preventing movement of the handle assembly is provided.

9.1.6 Iron and steel parts of a handle assembly shall be provided with corrosion protection in accordance with [10.1](#) or shall be constructed of stainless steel or other noncorrosive metal acceptable for the application.

9.1.7 A handle secured by a single fastening means shall be prevented from rotating by means other than friction. A lockwasher alone shall not be sufficient.

9.2 Handle assembly

9.2.1 A handle assembly for a percolator, kettle, carafe, or other vessel used to lift, tilt, and hold a beverage shall be subjected to the requirements of Dynamic load, [41.7](#). This test is not to be applied to a

percolator, kettle, carafe, or other hot liquid container vessel in which the handle and vessel (or vessel outer enclosure) are molded of one continuous material.

10 Corrosion Protection

10.1 Iron and steel parts shall be protected against corrosion by enameling, galvanizing, plating, or other equivalent means, if the deterioration of such unprotected parts increases the risk of fire or electric shock.

Exception: Where the oxidation of steel is not likely to be accelerated due to the exposure of metal to air and moisture or other oxidizing influence – thickness of metal and temperature also being factors – surfaces of sheet steel within an enclosure may not be required to be protected against corrosion. Cast-iron parts are not required to be protected against corrosion. A sheath employed on a heating element operating in air and terminal parts attached directly to the heating element need not be protected against corrosion.

10.2 The aging characteristics of plating or other finish used in an appliance shall be such that deterioration of the finish does not result in unacceptable performance of the appliance.

11 Supply Connections

11.1 General

11.1.1 An appliance shall be provided with a length of attached flexible cord and an attachment plug for connection to the supply circuit, or shall have male pin terminals that accommodate a detachable power-supply cord. The length of flexible cord shall be within the limits indicated in [Table 11.1](#).

Table 11.1
Lengths of cord connection

Means of dispensing liquid	Kind of cord connection	Minimum acceptable length ^a		Maximum acceptable length ^{a,c}	
		Feet	(Meters)	Feet	(Meters)
Lifting and tilting appliance	Attached cord or detachable power-supply cord	2.0	(0.6)	3.0	(0.9)
	Coiled (retractile) detachable power-supply cord	–	–	3.0 ^b	(0.9) ^b
Separable vessel, spigot or the like	Attached cord or detachable power-supply cord	2.0	(0.6)	7.0	(2.1)

^a Measured external to the appliance and including the fittings but excluding the blades on the attachment plug.

^b Measured with the cord relaxed on a horizontal surface. Measured with the cord fully extended, the length is not to exceed 7.0 ft (2.1 m) and is not to be less than 6.0 ft (1.8 m).

^c An appliance shall be provided with instructions in accordance with [54.7](#) or [54.8](#), whichever is applicable.

11.1.2 The rating (both current and voltage) of the cord and the fittings of a nondetachable and a detachable power supply cord, shall not be less than that of the appliance.

11.1.3 A 3- to 2-wire grounding-type adapter shall not be provided with an appliance.

11.1.4 An attached flexible cord and the cord in a detachable power-supply cord that is provided with an appliance shall be of a Type HPD, HPN, HSJ, HSJO, SP-2, SPE-2, SPT-2, SV, SVE, SVO, SVT, SVTO, SJ, SJE, SJO, SJT, or SJTO cord, or shall have such properties that are at least equally as serviceable for the particular application.

11.1.4.1 A cord set or power supply cord shall comply with the Standard for Cord Sets and Power-Supply Cords, UL 817.

11.1.4.2 Flexible cords and cables shall comply with the Standard for Flexible Cords and Cables, UL 62. Flexible cord and cables are considered to fulfill this requirement when preassembled in a cord set or power supply cord complying with the Standard for Cord Sets and Power-Supply Cords, UL 817.

11.1.5 Supplementary insulation, if employed, shall not extend more than 1/2 inch (13 mm) outside the appliance (unless provided with additional mechanical protection), shall be prevented from fraying or unraveling, and shall not affect adversely the means for providing strain relief.

11.1.6 The attachment plug of the power supply cord of an appliance provided with a 15- or 20- ampere general use receptacle shall be of the 3-wire grounding type. The attachment plug of the power supply cord of an appliance provided with a manually operated, line-connected, single pole switch for appliance on-off operation, or an Edison base lampholder, shall be of the polarized or grounding type.

11.1.7 If a 3-wire grounding-type attachment plug or a 2-wire polarized attachment plug is provided, the attachment plug connection shall comply with [Figure 11.1](#) and the polarity identification of the flexible cord shall comply with [Table 11.3](#).

ULNORM.COM : Click to view the full PDF of UL 1082-2024

Figure 11.1

Connections to attachment plug

CONNECTIONS OF CORD CONDUCTORS TO GROUNDING – TYPE ATTACHMENT PLUG (FACE OF PLUG REPRESENTED)

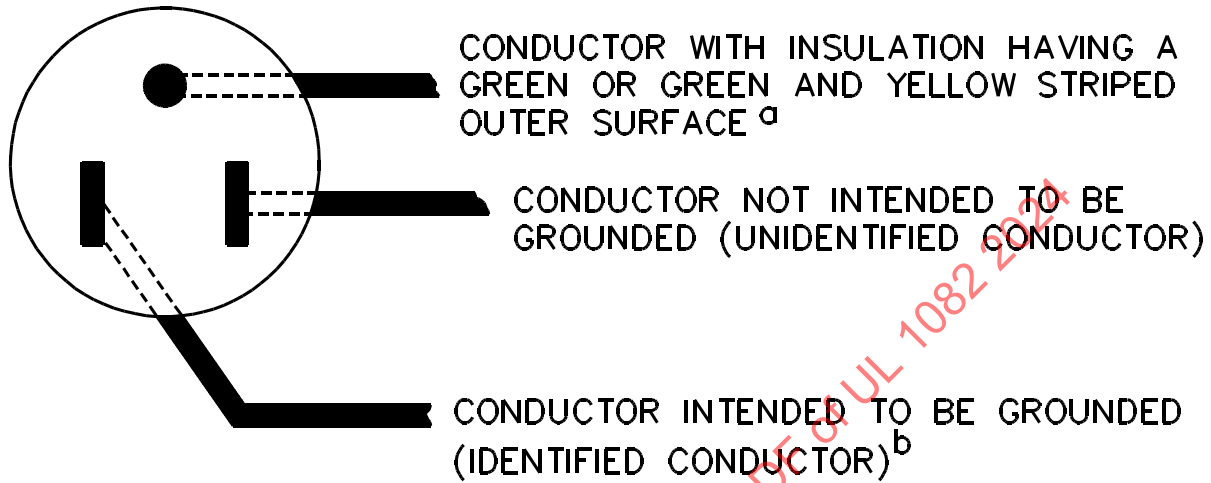

CONNECTIONS OF CORD CONDUCTORS TO POLARIZED ATTACHMENT PLUG (FACE OF PLUG REPRESENTED)

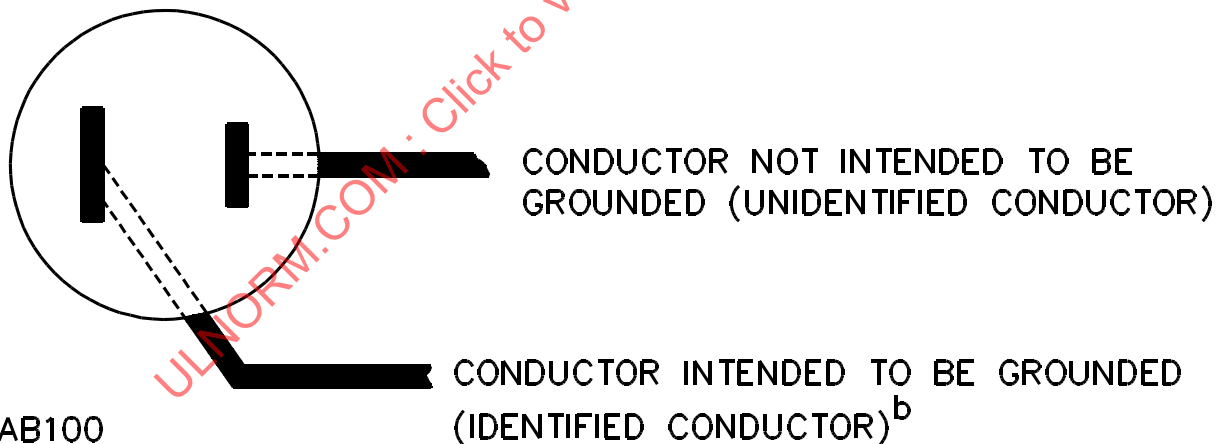

AB100

^a In the above illustration, the blade to which the green conductor is connected may have a U-shaped or circular cross section.

^b Signifies a conductor identified in accordance with [Table 11.3](#).