

---

---

**Ostomy collection bags —**  
**Part 2:**  
**Requirements and test methods**

*Poches de recueil pour stomie —*

*Partie 2: Prescriptions et méthodes d'essai*

STANDARDSISO.COM : Click to view the full PDF of ISO 8670-2:1996



## Contents

Page

1	Scope .....	1
2	Normative reference .....	1
3	Definitions .....	1
4	Requirements .....	2
5	General test conditions .....	2
6	Test methods .....	2
7	Test reports .....	8

STANDARDSISO.COM : Click to view the full PDF of ISO 8670-2:1996

© ISO 1996

All rights reserved. Unless otherwise specified, no part of this publication may be reproduced or utilized in any form or by any means, electronic or mechanical, including photocopying and microfilm, without permission in writing from the publisher.

International Organization for Standardization  
Case postale 56 • CH-1211 Genève 20 • Switzerland  
Internet: central@isocs.iso.ch  
X.400: c=ch; a=400net; p=iso; o=isocs; s=central

Printed in Switzerland

## Foreword

ISO (the International Organization for Standardization) is a worldwide federation of national standards bodies (ISO member bodies). The work of preparing International Standards is normally carried out through ISO technical committees. Each member body interested in a subject for which a technical committee has been established has the right to be represented on that committee. International organizations, governmental and non-governmental, in liaison with ISO, also take part in the work. ISO collaborates closely with the International Electrotechnical Commission (IEC) on all matters of electrotechnical standardization.

Draft International Standards adopted by the technical committees are circulated to the member bodies for voting. Publication as an International Standard requires approval by at least 75 % of the member bodies casting a vote.

International Standard ISO 8670-2 was prepared by Technical Committee ISO/TC 173, *Technical systems and aids for disabled or handicapped persons*, Subcommittee SC 3, *Aids for ostomy and incontinence*.

This second edition cancels and replaces the first edition (ISO 8670-2:1991) which has been technically revised.

ISO 8670 consists of the following parts, under the general title *Ostomy collections bags*:

- *Part 1: Vocabulary*
- *Part 2: Requirements and test methods*

## Introduction

Users of this part of ISO 8670 are advised to consider the desirability of third-party certification of product conformity with this part of ISO 8670, based on testing and continuing surveillance, which may be coupled with assessment of a supplier's quality system against the appropriate standards in the ISO 9000 series.

STANDARDSISO.COM : Click to view the full PDF of ISO 8670-2:1996

# Ostomy collection bags —

## Part 2: Requirements and test methods

### 1 Scope

This part of ISO 8670 specifies performance requirements and test methods for one-piece and multiple-piece ostomy systems having collection bags of the following types:

- a) closed-ended bags;
- b) open-ended bags;
- c) urostomy bags.

### 2 Normative reference

The following standard contains provisions which, through reference in this text, constitute provisions of this part of ISO 8670. At the time of publication, the edition indicated was valid. All standards are subject to revision, and parties to agreements based on this part of ISO 8670 are encouraged to investigate the possibility of applying the most recent edition of the standard indicated below. Members of IEC and ISO maintain registers of currently valid International Standards.

ISO 8670-1:1996, *Ostomy collection bags — Part 1: Vocabulary*.

### 3 Definitions

For the purposes of this part of ISO 8670, the definitions given in ISO 8670-1 and the following definitions apply.

- 3.1 flatus filter:** Device that contains a porous material for deodorizing flatus as it escapes from the bag.
- 3.2 multiple-piece flange system:** Effluent collection system in which a component is positioned around the stoma allowing an effluent collection bag to be attached or removed while the component itself remains in position.
- 3.3 ostomy bag:** Flexible container for collecting body effluent from the stoma.
- 3.4 stoma:** Abnormal opening established on the body surface.
- 3.5 test volume:** That volume on which is based the volume of liquid added, or the force applied, to an ostomy collection bag when performing tests to verify the strength and leakage resistance of the bag assembly.

## 4 Requirements

### 4.1 Freedom from leakage

4.1.1 When tested by the method given in 6.2, bags without flanges shall not leak.

4.1.2 When tested by the method given in 6.3, bags (systems) with flanges shall not leak.

### 4.2 Retention of open-ended bag closure

When tested by the method given in 6.4, the open-ended bag closure shall remain in position when used following the bag manufacturer's instructions.

### 4.3 Burst strength (static)

When tested by the method given in 6.5, the bag shall not leak.

### 4.4 Marking of the ostomy collection system

4.4.1 For identification purposes, the bag shall be marked with at least the product code and the name and/or trademark of the manufacturer or supplier.

4.4.2 If the opening for the stoma is intended to be enlarged, the maximum opening shall be either

- a) marked on the product
- or
- b) given in the instructions.

## 5 General test conditions

### 5.1 Temperature

The standard temperature for testing (atmosphere and reagent) shall be  $23\text{ °C} \pm 2\text{ °C}$ .

### 5.2 Test samples

Testing shall be carried out on product samples as supplied to the end-user.

## 6 Test methods

### 6.1 Test volume

#### 6.1.1 Principle

The ostomy collection bag is filled with water and the volume of water within the bag is measured.

#### 6.1.2 Reagent

##### 6.1.2.1 Tap water.

### 6.1.3 Apparatus

**6.1.3.1 Rigid transparent plate** (see figure 1), of sufficient size to support the whole of the bag in the horizontal position, having a hole of diameter  $10 \text{ mm} \pm 0,2 \text{ mm}$  to which a connector fitted with a tap can be secured.

**6.1.3.2 Means of filling the bag**, from the tap or reservoir, ensuring that air is not entrained.

**6.1.3.3 Graduated cylinders**, of capacities to suit the bags being tested and having a measurement accuracy of  $\pm 2 \%$ .

Dimensions in millimetres

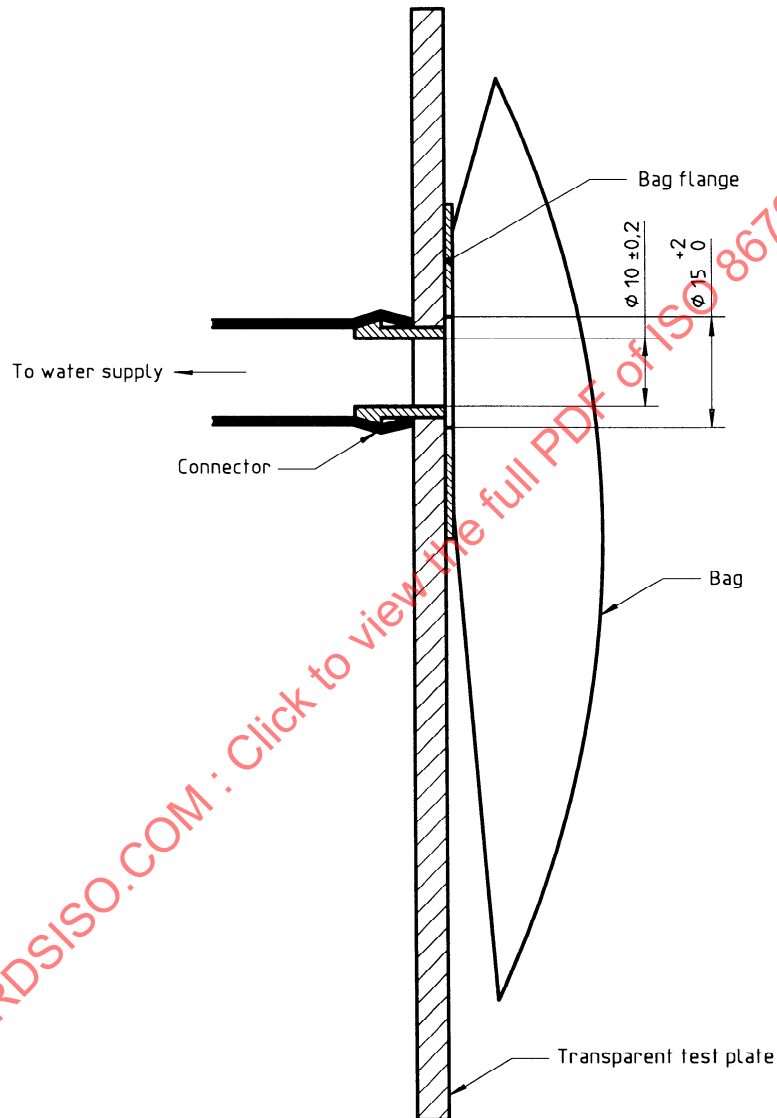

Figure 1 — Set-up for measuring test volume

### 6.1.4 Procedure

**6.1.4.1** For open-ended bags with a bottom opening, close the outlet  $30 \text{ mm} \pm 5 \text{ mm}$  from the bottom by welding or by repeated folding secured with a binder clip or other securing device not exceeding 100 g in mass. For open-ended bags with a top opening, close the opening in accordance with the manufacturer's instructions.

Do not use a rubber band for closure purposes.

**6.1.4.2** If there is no precut opening in the ostomy bag assembly, or if the opening is of diameter less than 15 mm, cut a central hole of diameter  $15 \text{ mm}^{+2}_0 \text{ mm}$ .

**6.1.4.3** With the rigid transparent test plate (6.1.3.1) in a vertical position, attach the ostomy bag assembly so the bag opening is concentric with the hole in the test plate. Ensure that the bag is positioned so that its movement is not restricted.

**6.1.4.4** Remove as much air as possible from the ostomy bag under test. In the case of urostomy bags, this may mean opening the drainage tap while pressing against the bag, and then closing the drainage tap.

Insert the filling connector (6.1.3.2) into the test plate with the tap in the closed position.

**6.1.4.5** Open the water supply tap (6.1.2.1) and allow water to enter the bag, ensuring that no air is entrained, until the level of water in the bag reaches the bottom of the hole in the test plate. Turn off the tap.

**6.1.4.6** Remove the filling connector from the test plate and allow the level of water in the bag to stabilize for  $1 \text{ min}^{+10}_0 \text{ s}$ .

**6.1.4.7** If necessary, remove or add water to the bag using the filling connector until the water in the bag is level with the bottom of the hole in the test plate when filling connector is removed.

NOTE — In the case of urostomy bags, two water levels may be observed, one on each side of the nonreturn valve. In this case, the upper water level at the flange opening is used to establish the test volume.

**6.1.4.8** Empty the water from the bag into a graduated cylinder (6.1.3.3). Measure the volume, in millilitres, and record it as the test volume of the bag.

## 6.1.5 Test report

The test report shall contain the general information specified in clause 7, together with the test volume.

## 6.2 Freedom from leakage of bags without flanges

### 6.2.1 Principle

The ostomy collection bag is filled with coloured water, positioned horizontally and examined for leakage. It is then suspended vertically and again examined visually for leakage.

This method does not test for:

- a) leakage from vents, filters, vent and filter plugs and the interface between the test surface and the bag assembly;
- b) leakage from the open-ended bag closure.

### 6.2.2 Reagent

**6.2.2.1 Coloured water**, comprising tap water coloured by the addition of 0,3 g/l of erythrosin (E 127).

### 6.2.3 Apparatus

**6.2.3.1 Rigid, transparent test plate**, as specified in 6.1.3.1.

**6.2.3.2 Means of sealing** all openings not to be tested.

**6.2.3.3 Absorbent material**, white.



## 6.2.4 Procedure

**6.2.4.1** Seal all openings (see 6.2.3.2), such as vents, filters and openings of open-ended bags, and attach the bag to the test plate (6.1.3.1). If there is no pre-cut opening for the stoma, cut a hole as described in 6.1.4.2. Attach the bag to the test plate as described in 6.1.4.3.

**6.2.4.2** If the bag is a urostomy bag fitted with a drainage tap, pour a small amount of coloured water (6.2.2.1) into the bag and open and close the tap ten times, ensuring that the coloured water is present in the bag during the whole operation.

**6.2.4.3** Position the bag/test plate assembly vertically and fill the bag through the filling port with 75 % of the test volume (see 6.1.4.8) using the coloured water, ensuring that air is not entrained.

**6.2.4.4** Visually inspect the bag for leakage after  $1 \text{ min} +_0^5 \text{ s}$ . If leakage is observed, discontinue the test.

**6.2.4.5** Close the inlet hole and dry the surface of bag assembly. Position the bag/test plate assembly horizontally beneath the bag with the absorbent material (6.2.3.3) between the bag and test plate. Leave undisturbed for  $17 \text{ h} \pm 1 \text{ h}$  and then visually inspect the bag and absorbent material for signs of leakage. Discontinue the test if leakage has occurred.

**6.2.4.6** Reposition the same bag/test plate assembly in a vertical position with absorbent material beneath it. Leave undisturbed for  $4 \text{ h} \pm 1 \text{ h}$ , then visually inspect for signs of leakage.

## 6.2.5 Test report

The test report shall contain the general information specified in clause 7, together with a statement as to whether or not leakage was observed and, if so, at which orientation.

## 6.3 Freedom from leakage of systems with flanges

### 6.3.1 Principle

The ostomy collection bag is attached to a vertical plate and a force is applied in upward and downward directions sequentially. The bag is filled with coloured water and positioned horizontally. The junction between the bag and the flange and the junction of the multiple-piece coupling system are then inspected for leakage or visible damage.

### 6.3.2 Reagent

**6.3.2.1 Coloured water**, as specified in 6.2.2.

### 6.3.3 Apparatus

**6.3.3.1 Rigid, transparent test plate**, as specified in 6.1.3.1.

**6.3.3.2 Means of applying a force** of  $20 \text{ N} \pm 1 \text{ N}$  to the bag.

**6.3.3.3 Stopwatch**, or similar timing device.

### 6.3.4 Procedure

**6.3.4.1** Attach the ostomy collection bag or the baseplate of a multiple-piece ostomy collection system to the test plate (6.3.3.1) using the procedure described in 6.2.4.1 (see figure 2).

For a multiple-piece flange system, assemble in accordance with the manufacturer's instructions.

**6.3.4.2** Slowly apply a force (6.3.3.2) of  $20 \text{ N} \pm 1 \text{ N}$  in a downward direction towards the bottom of the bag.

6.3.4.3 Maintain the force for  $1 \text{ min } +10_0 \text{ s}$ , then remove it.

6.3.4.4 Slowly apply a force of  $20 \text{ N} \pm 1 \text{ N}$  in an upward direction towards the top of the bag, or rotate the plate  $180^\circ$  and apply the test force in a downward direction.

6.3.4.5 Maintain the force for  $1 \text{ min } +10_0 \text{ s}$ , then remove it.

6.3.4.6 Add 75 % of the test volume (see 6.1.4.8) of coloured water (6.3.2.1) to the bag, avoiding entraining air. Seal the opening in the plate and place the plate and bag on a horizontal surface, with the test plate beneath the bag and the absorbent material between the bag and test plate.

6.3.4.7 After 30 min but before 31 min, visually examine the junction of the flange to the bag and the junction of the multiple-piece flange system for leakage.

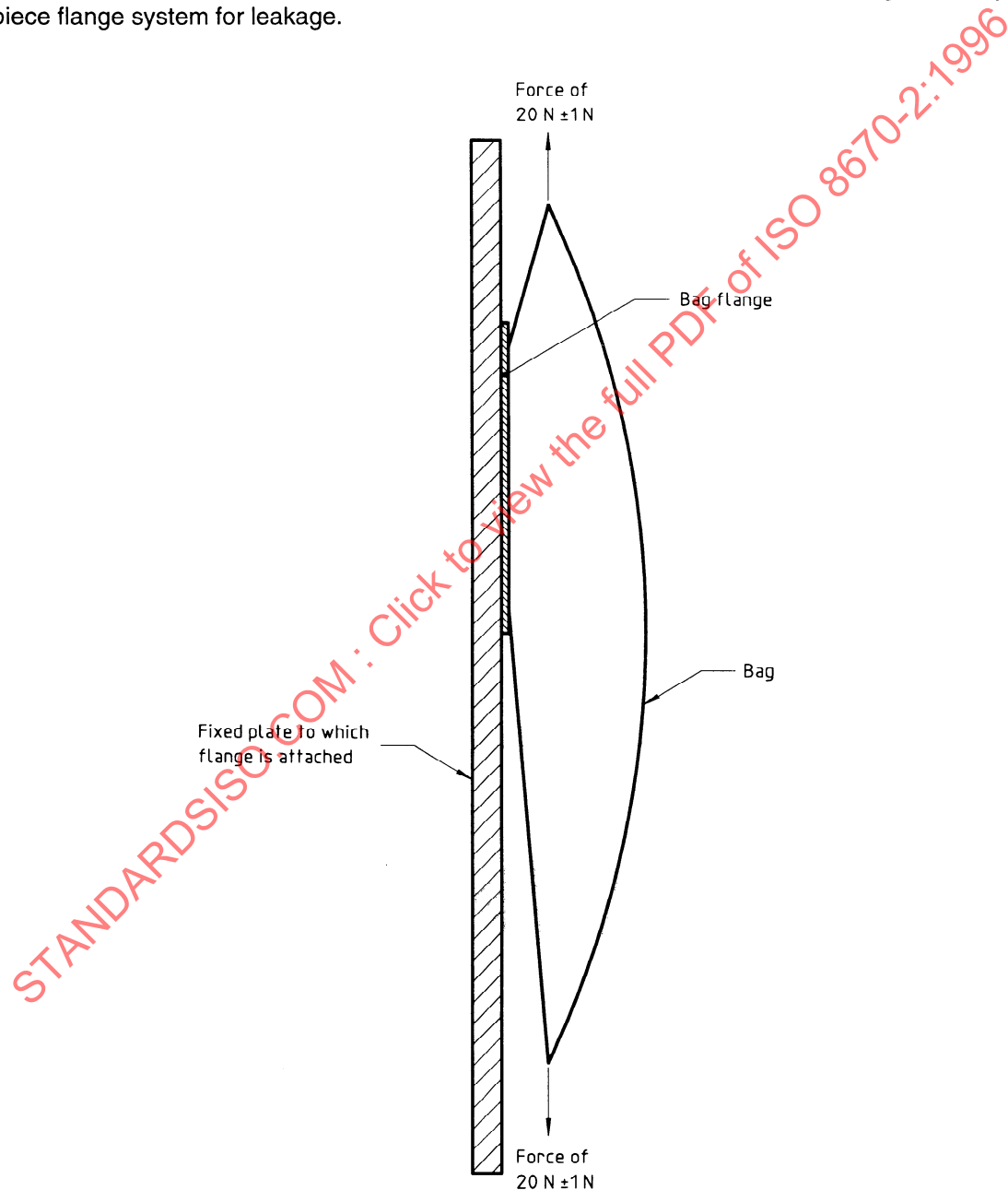

Figure 2 — Set-up for testing for flange leakage

### 6.3.5 Test report

The test report shall contain the general information specified in clause 7, together with a statement as to whether or not leakage was observed.

## 6.4 Retention of an open-ended bag closure

### 6.4.1 Principle

The ostomy collection bag is filled with water and subjected to a compressive force. It is then visually examined for retention of the open-ended bag closure.

### 6.4.2 Reagent

#### 6.4.2.1 Tap water.

### 6.4.3 Apparatus

**6.4.3.1 Parallel plates**, of length and width not less than those of the bag being tested, with one plate having a hole of diameter 10 mm positioned in its centre, with the plate capable of moving freely in a vertical direction while remaining horizontal within a tolerance of  $\pm 5^\circ$ .

**6.4.3.2 Means of applying a force** of  $100 \text{ N} \pm 5 \text{ N}$  to the bag.

**6.4.3.3 Stopwatch**, or similar timing device.

### 6.4.4 Procedure

**6.4.4.1** Seal all openings, as described in 6.2.4.1, and attach the bag to the test plate (6.4.3.1) having the hole in it, as described in 6.1.3.1.

**6.4.4.2** Apply the open-ended bag closure, in accordance with the manufacturer's instructions.

**6.4.4.3** Fill the bag with 75 % of the test volume (see 6.1.4.8) of water, avoiding entraining air, and seal the opening in the plate. Orientate the plate in a horizontal position with the bag uppermost.

**6.4.4.4** Place the other plate on the bag in a position parallel with the lower plate.

**6.4.4.5** Load the upper plate so that a force of  $100 \text{ N} \pm 5 \text{ N}$  is imposed on the bag, ensuring that the bag components do not impair application of the load. Ensure that the plates do not restrict movement of the bag closure.

**6.4.4.6** Allow the force to act on the bag for  $1 \text{ min}^{+10}_0 \text{ s}$ , remove the force and visually inspect the bag to determine whether the open-ended closure remained in position.

### 6.4.5 Test report

The test report shall contain the general information specified in clause 7, together with a statement whether or not the open-ended closure remained in position.

## 6.5 Burst strength (static)

### 6.5.1 Principle

This method tests for leakage of water from all parts of ostomy bags except as noted in 6.2.1.

The bag is filled with water and subjected to a compressive force, then inspected for leakage.

## 6.5.2 Reagent

### 6.5.2.1 Tap water.

## 6.5.3 Apparatus

### 6.5.3.1 Parallel plates, as specified in 6.4.3.1.

### 6.5.3.2 Means of applying a force of $200\text{ N} \pm 5\text{ N}$ to the bag.

### 6.5.3.3 Stopwatch, or similar timing device.

## 6.5.4 Procedure

**6.5.4.1** Seal all openings as described in 6.2.4.1, and attach the bag to the test plate (6.5.3.1) having the hole in it, as described in 6.1.3.1.

**6.5.4.2** If the bag is fitted with a drainage tap, fully open it and close it ten times. If the bag is an open-ended bag, clamp or otherwise occlude the outlet opening so that it is fluid-tight, without using the open-ended bag closure.

**6.5.4.3** Fill the bag with 75 % of the test volume (see 6.1.4.8) with water (6.5.2.1), avoiding entraining air and seal the opening in the plate. Orientate the plate in a horizontal position with the bag uppermost.

**6.5.4.4** Place the other plate on the bag in a position parallel with the lower plate.

**6.5.4.5** Load the upper plate so that a force of  $200\text{ N} \pm 5\text{ N}$  is imposed on the bag, ensuring that the bag components do not impair application of the load. Ensure that the plates do not restrict movement of the bag closure.

**6.5.4.6** Allow the force to act on the bag for  $1\text{ min}^{+10}_0\text{ s}$ , remove the force and visually inspect the bag to determine whether or not leakage occurred.

## 6.5.5 Test report

The test report shall contain the general information specified in clause 7, together with a statement as to whether or not leakage was observed.

## 7 Test reports

The test reports shall include the following information:

- a) reference to this part of ISO 8670;
- b) complete identification of the bag, tested as described in 4.4;
- c) date and place of testing;
- d) number of bags tested;
- e) test results as specified in 6.1.5, 6.2.5, 6.3.5, 6.4.5 and 6.5.5.